

Custom-Request Plywood Substrate Option

If a custom request was made for plywood wall substrate, then the hollow bolts in the speed frames must be replaced to accommodate the larger 5/16" lag bolts (Daktronics part number HC-5100786) needed for attachment to plywood.

Remove the standard hollow bolts (HC-5098752) and replace with the hollow bolts needed for the plywood fasteners (HC-5098762). Refer to **Figure 1**.

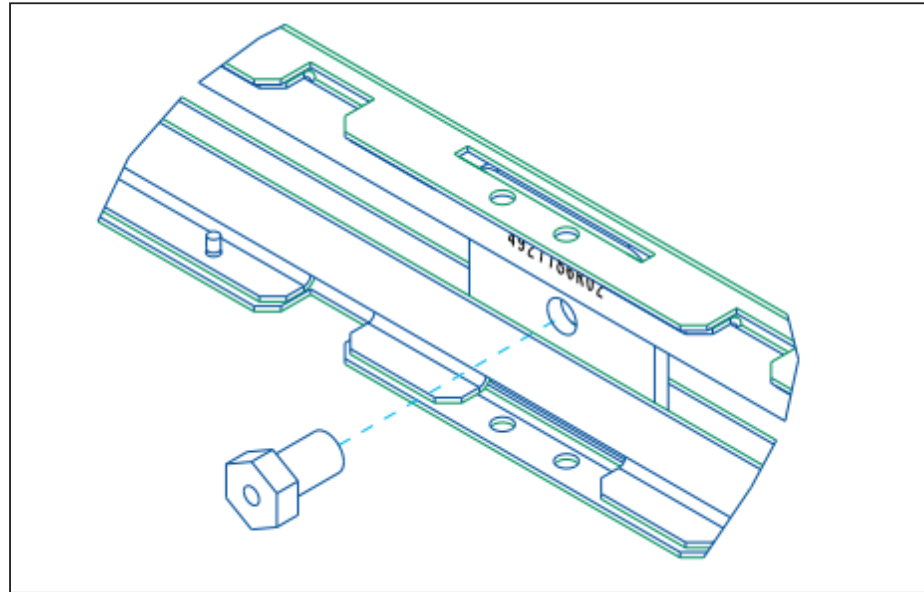

Figure 1: Remove Standard Bolts and Install Custom Bolts

The difference between the hollow bolts are the through-hole diameters. Refer to **Figure 2**.

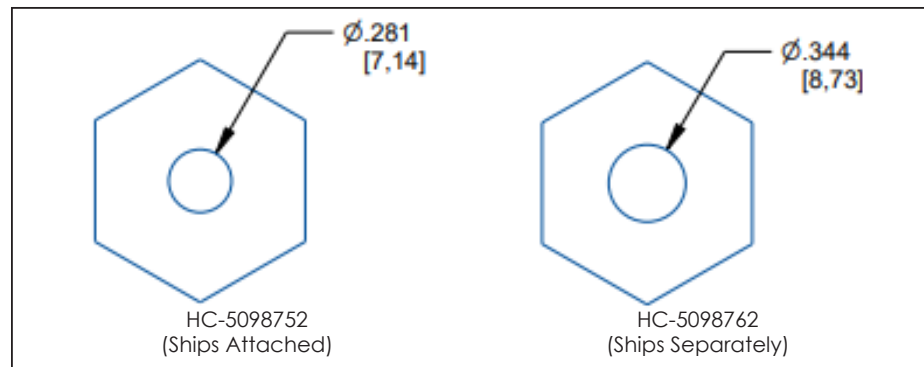

Figure 2: Comparison of Standard and Custom Hollow Bolts

Frame Installation

Install First Frame

Note: These steps are easiest with two to three people.

1. Identify the stud locations on the wall and mark the top, middle, and bottom of the studs. Use a level to draw lines the height of the display and mark the studs.
2. Identify the position of the bottom-center frame.

3. Cut the zip ties from the first frame. Test each bolt assembly to verify that it slides freely.

Note: If the assembly binds, tap a hammer on the side of the steel plate to break it loose.

4. Mark the location for the perimeter of the frame on the wall. Use this mark to position the first frame. Hold the frame in place on the wall and use a 4' digital level on the top and sides of the frame while positioning it. Refer to **Figure 3**.

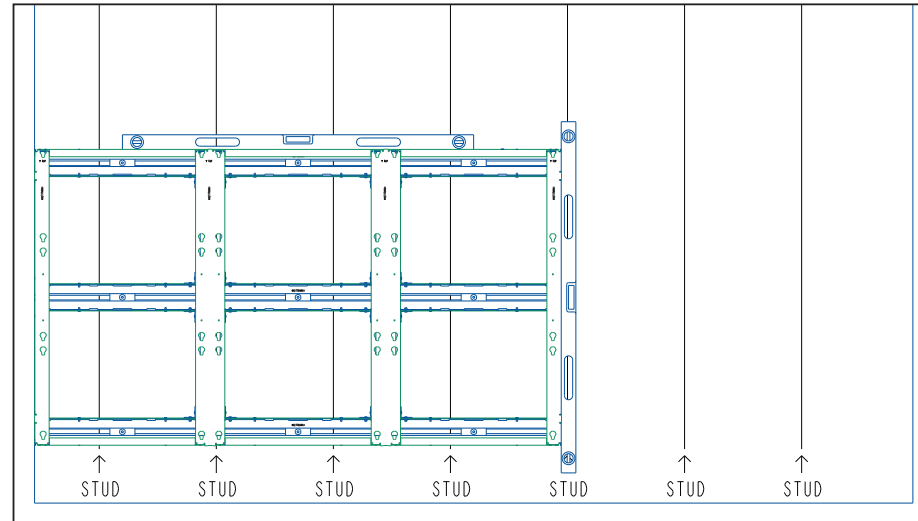

Figure 3: Position Frame on Wall

5. Slide the bolt assemblies to the nearest stud lines.
6. Depending on site-specific conditions, attach the frame to the substrate using TEK screws (HC-3979953), Spax screws, or lag screws. Install the screws through the hollow bolts into the respective studs. Start with the frame corners first, and fill in remaining available screws. Refer to **Figure 4**.

Note: Do not tighten the screws.

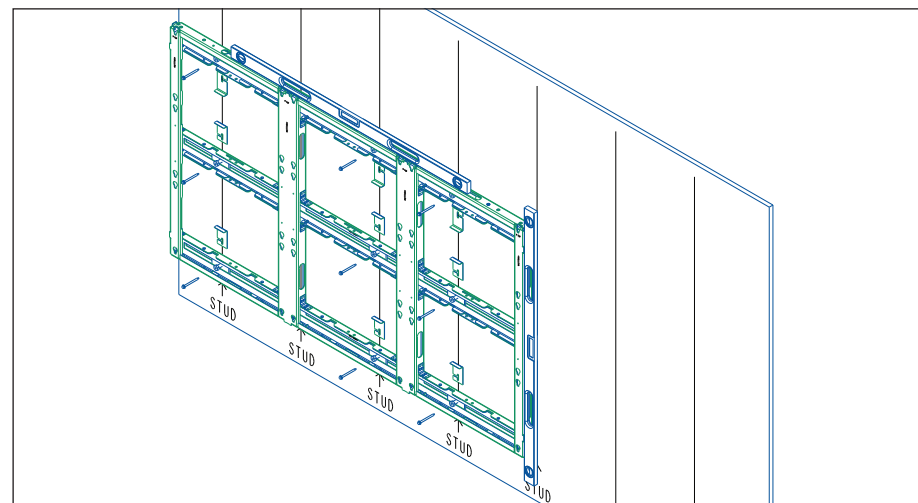

Figure 4: Install TEK Screws in Remaining Bolt Assemblies

7. Install the brace plate (0M-4951150) after starting a screw in the stud.

Note: Ensure that the brace plate is positioned on the screw and lands between the wall and the tip of the hollow bolt. The brace plate provides a strong surface to adjust the Z-axis position of the frame. If the brace plate is not placed properly, the tip of the hollow bolt will cut and sink into the wall material.

8. Tighten the screws until the frame is fixed in place.
9. Use a level on the top and side of the frame and repeat **Steps 6** and **7** for the remaining bolt assemblies.
10. Place a level on the face of the vertical members in the frame to ensure the frame is plumb and level. Adjust the Z-position of the frame as needed. Refer to **Adjust Frame Z-Position (p.1)**.

Note: Ensure the frame position aligns to the marked location on the wall.

Adjust Frame Z-Position

1. Identify the bolt assembly locations to adjust away from the wall. Refer to **Figure 5**.

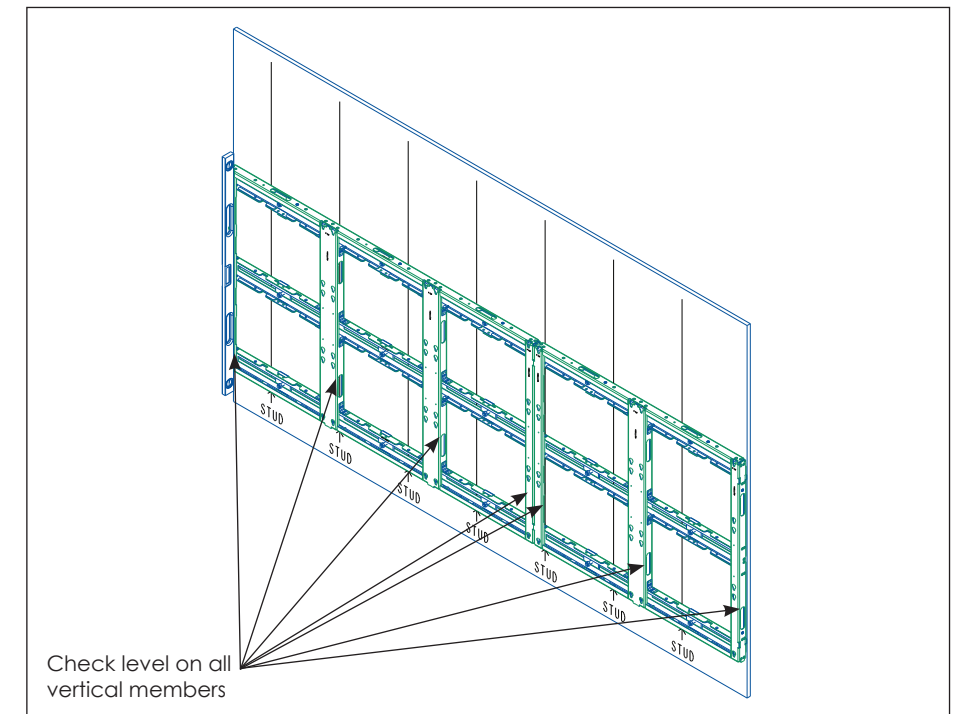
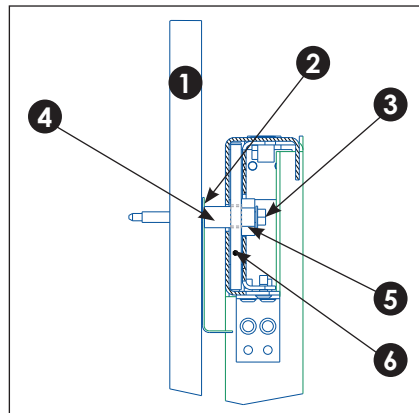

Figure 5: Identify Bolt Assemblies to Z-Adjust

2. Adjust one bolt assembly at a time. Refer to **Figure 6**.

- a. Loosen the TEK screw.
- b. Tighten the hollow bolt into the threaded plate until the end of the bolt braces against the brace plate. Continue until the face of the frame is level.
- c. Tighten the TEK screw to lock the Z-position in place.



- 1: Sheetrock
- 2: Backer plate
- 3: TEK screw
- 4: Fully adjusted bolt
- 5: Hollow bolt
- 6: Threaded plate

Figure 6: Adjust Z-Position of Bolt Assembly

Install Next Adjacent Frame in First Row

1. Position the adjacent frame in the row next to the installed frame.
2. Install the supplied stitch bolts (HC-1842). Refer to **Figure 7**.

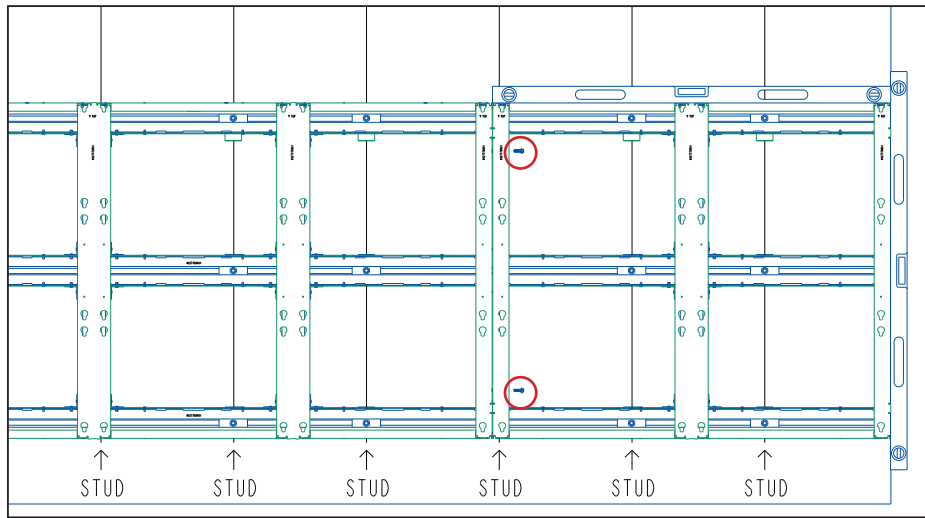

Figure 7: Install Stitch Bolts

3. Ensure the alignment tabs are flush and even with each other. Refer to **Figure 8**. Tighten the stitch bolts to lock the tabs into place.

Note: Tighten the bolts to just snug, being sure to not deform the frames.

4. Cut the zip ties and verify that the bolt assemblies slide freely.
5. Slide the bolt assemblies to the nearest stud lines.
6. Use a 4' level on top of the frame to level the frame while positioning it.

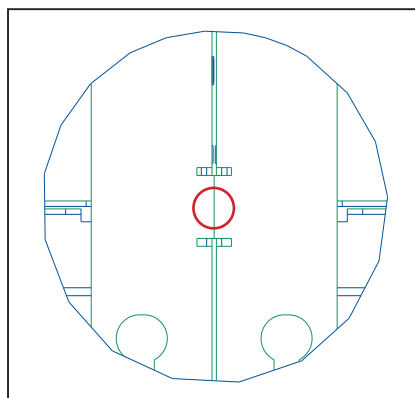

Figure 8: Ensure Alignment Tabs Are Flush & Even

7. Repeat **Steps 5–7** in **Install First Frame (p.1)**.

8. Repeat **Steps 1–7** in **Install Next Adjacent Frame in First Row (p.2)** until the first row is fully installed.

9. Use a string line across the installed bottom row and adjust the Z-position of the frames so the frame faces are all aligned to the string. Verify the frame faces are level vertically as they are adjusted for the string line.

Install Remaining Frames

1. Position the left frame in the next row on top of the first installed frame. Ensure the alignment tabs are flush and properly aligned. The mid verticals set the X- and Y-axis positions of the frame.
2. Install the supplied stitch bolts across the horizontal seam and tighten to lock the frame into place. Refer to **Figure 9**, **Figure 10**, and **Figure 11**.

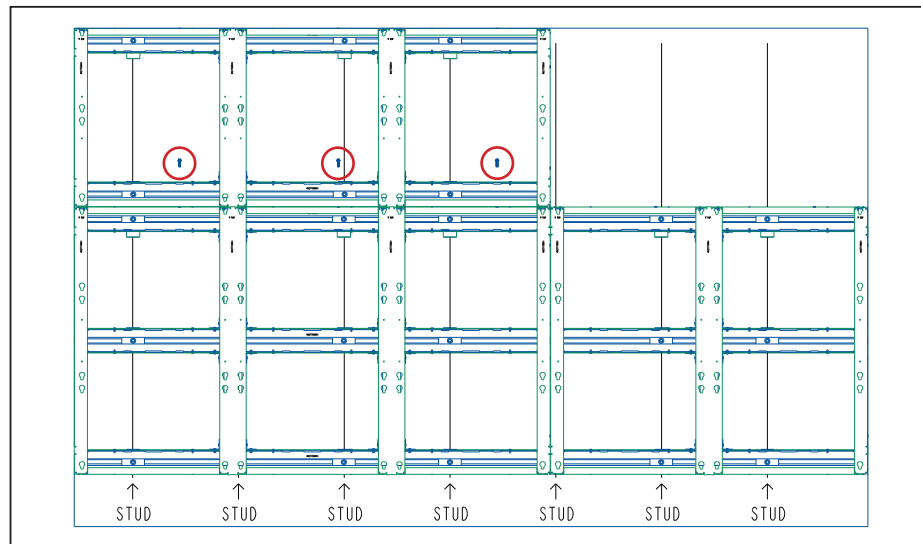

Figure 9: Install Stitch Bolts across Horizontal Seam

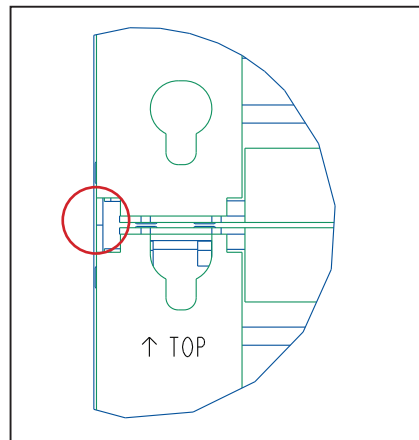

Figure 10: Ensure Alignment Tabs Are Flush & Even

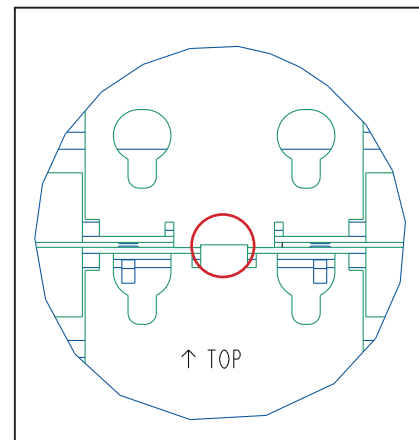

Figure 11: Lock X & Y Position

3. Cut the zip ties, allowing the bolt assemblies to slide along the track.
4. Slide the bolt assemblies to the nearest stud locations.

5. Install TEK screws and brace plates, but do not tighten all the way. Leave the TEK screws approximately 1/4" from tightened down, to allow room for Z-axis adjustment.

6. Install the remaining frames while leaving the frames slightly loose from the wall. Refer to **Figure 12**.

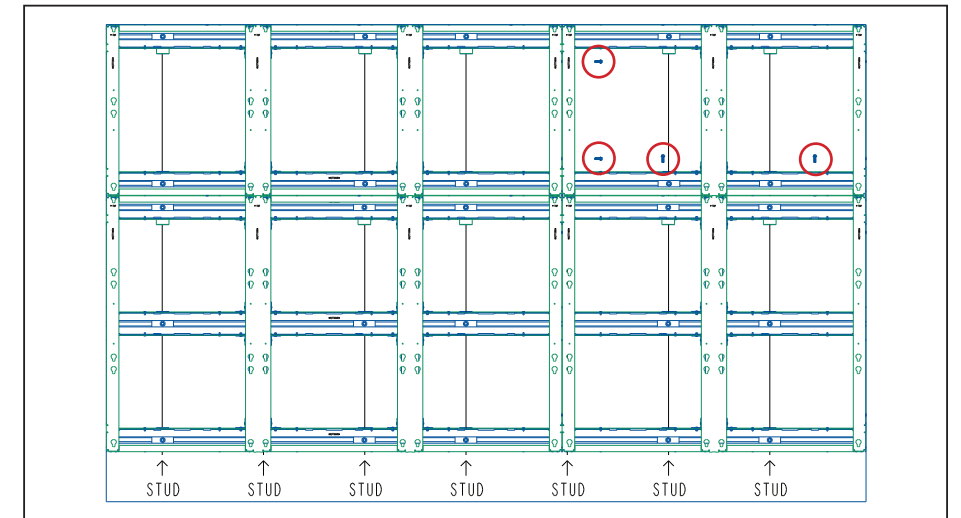

Figure 12: Install Remaining Frames

Plumb/Level Entire Display

1. Identify the wall high spot. Use a level on the face of the frame column while adjusting the Z-position of the frame column. If a high spot cannot be identified, start with the center-most frame column in the display.
2. Use the frame alignment tabs closest to the display corners and secure a string line in an X pattern. Refer to **Figure 13**.

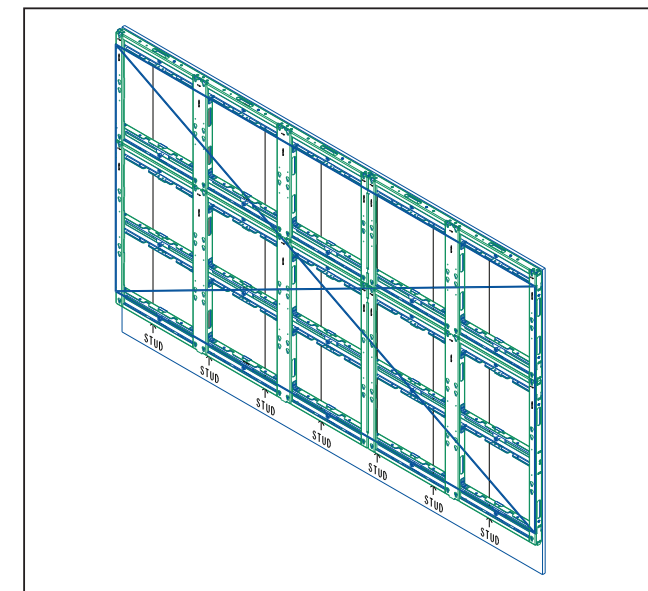

Figure 13: Secure String Line

- Identify frame high points along the string line. Adjust the Z-position toward the wall at the high points if the frames were not previously Z-adjusted. If the high-point frame was previously Z-adjusted, adjust the surrounding frames away from the wall to make the display face level and plumb.
- Tighten down the TEK screws to lock the frame Z-positions into place.
- Adjust the frame Z-positions until the faces are aligned to the string and the frame faces are plumb and level to each other.

Install Seismic Clips

- Place a seismic clip (0M-4983082) up to the secured mounting points in the frame. Refer to **Figure 14**.

Note: Ensure that the flange of the clip falls in the track opening and is pressed against the side of the threaded clip.

- Mark the location of one of the two holes in the clip to match the drill with the screw hole. Remove the clip.
- Drill a $\frac{5}{32}$ " diameter hole at the marked location.
- Replace the clip and secure with a #10-12 x $\frac{3}{8}$ " sheet metal screw (HC-1186) using the pre-drilled hole. Refer to **Figure 15**.
- Repeat clip installation steps for all frame mounting locations in the display.

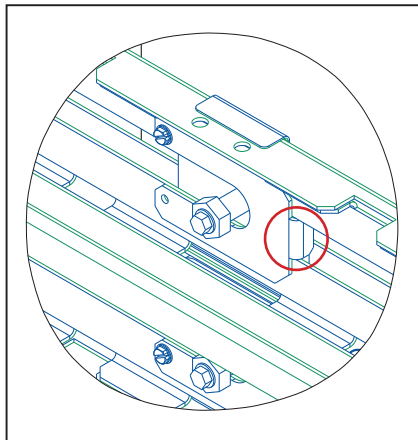

Figure 14: Position Seismic Clip

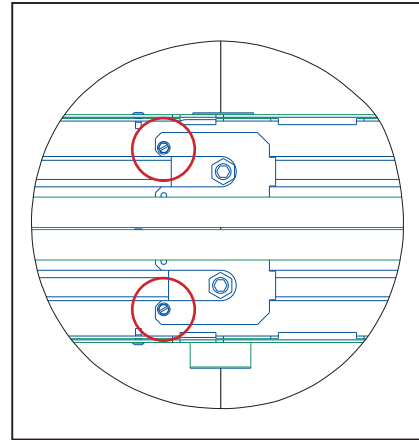

Figure 15: Secure Clip Screws

Panel Installation

Route Power & Signal

- Identify which panels will require power and/or signal inputs. Refer to the contract-specific Shop and Riser Drawings for details.
- Use the pass-through holes and notches in the frame to route the power and signal input cables from the input to the required input panel location prior to panel installation.

Note: Incoming power and signal cables external to the display cannot be routed after panels are installed.

Install First Panel

Note: If the display uses panel-embedded PLRs, identify the PLR panels using the two "PLR" labels. Refer to **Figure 16**. Refer to the contract-specific Signal Interconnect Drawing to position the PLR panels appropriately within the display.

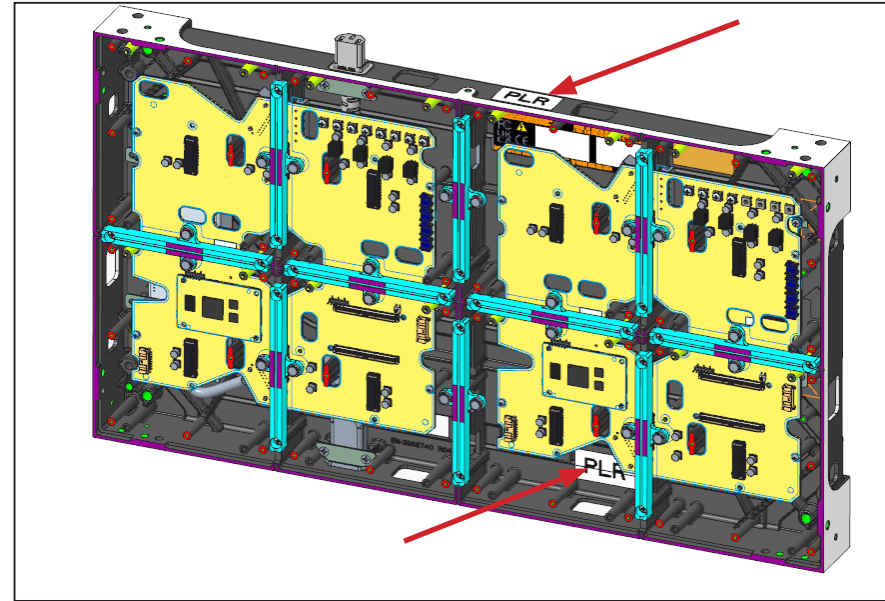

Figure 16: Identify PLR Panels Via Labels

- Remove the first panel from its packaging and install the hardware.
 - Install four M6 bolts (HC-1795) through the front of the panel. Refer to **Figure 17** and **Figure 18**.

Note: If necessary for Z-axis adjustment, ensure the bolt threads are engaged but not protruding out the rear of the panel.

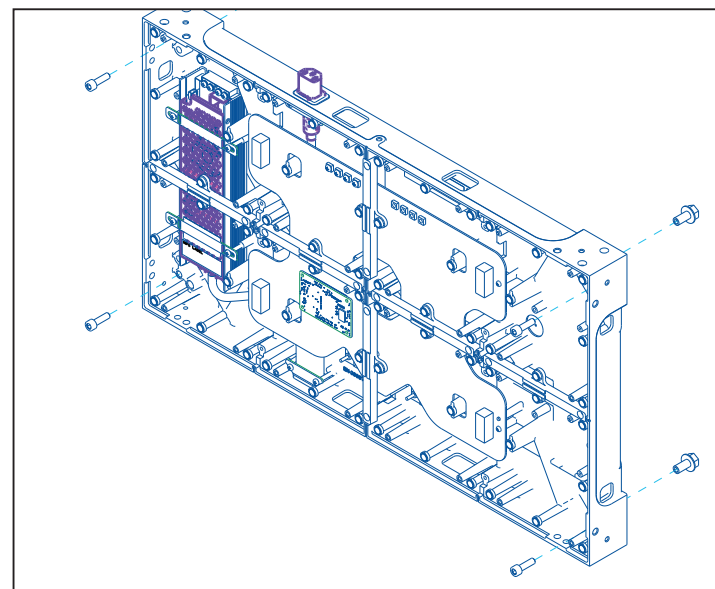

Figure 17: Install Hardware in First Panel

- Install four M8 bolts (HC-4884317) through the rear of the panel so the threads are engaged but not tightened all the way. Leave $\sim\frac{1}{4}$ " between the bolt flange and the rear of the panel. Refer to **Figure 17** and **Figure 18**.

- If installing a panel where power/signal needs to land, route the Cat 6 or Fiber incoming signal cable and/or the male end of the AC power input cable through the rectangular cutout in the panel prior to panel installation.

Note: Depending on the structure and access to the rear of the display, it may be very difficult or impossible to route power cables into the panel after the panel is secured to the tube.

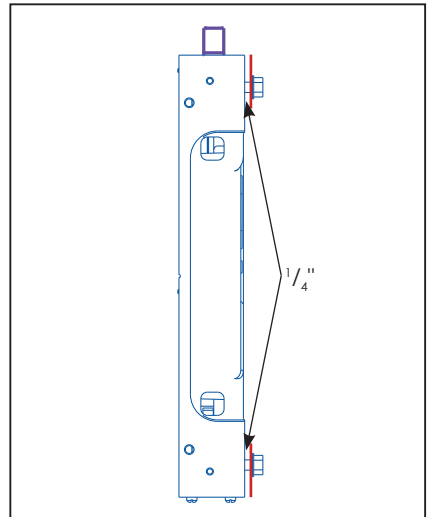

Figure 18: Leave $\frac{1}{4}$ " between Bolt Flange & Panel Rear

- Remove the two nuts (circled in red in **Figure 19**) securing the appropriate cover on the inside of the cabinet.
- Use a Phillips screwdriver to remove the two screws securing the power cable and the mounting bracket at the bottom of the panel. Refer to **Figure 20**.
- Install the power input cable through the rear of the panel and plug in the cable. Refer to **Figure 21**.

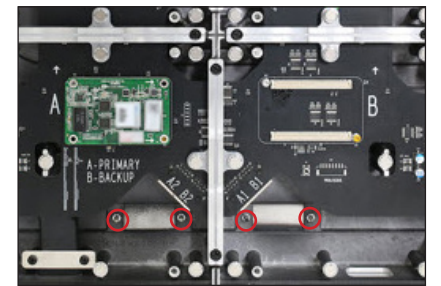

Figure 19: Remove Nuts from Cover



Figure 20: Remove Screws from Mounting Bracket



Figure 21: Install Power Input Cable

4. Repeat **Steps 1–3** for the remainder of the first row. Refer to **Figure 22**.

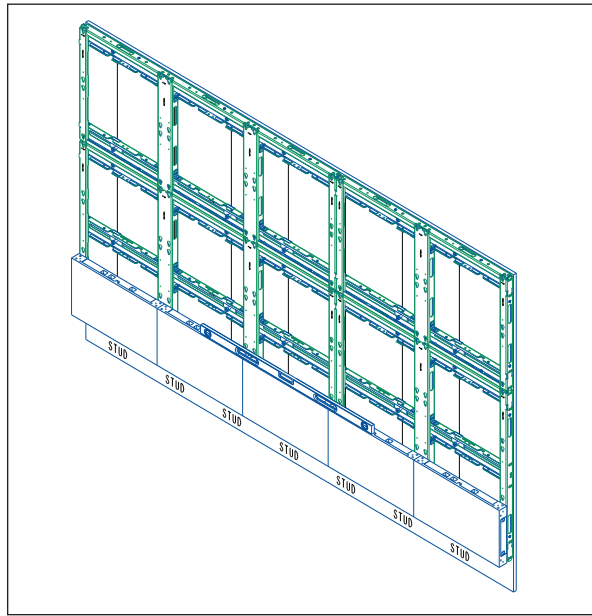

Figure 22: Install Remaining Panels in Bottom Row

5. Push the panels together and verify the far-left and far-right frame alignment tabs are not protruding beyond the display limits. Refer to **Figure 23**. Shift the panels left or right as needed.

6. Start at the center of the display and use a 5 mm hex key in the end of the M8 bolt to tighten the panel hardware. Level the top of the panel while tightening.

7. Install the panel side stitch bolts across the bottom row of panels while ensuring the machined tops, bottoms, and faces are all flush to each other. Use a 5 mm key to tighten the stitch bolts.

8. Tighten the M8 bolts in the first row of panels until the bolts are snug to the frame.

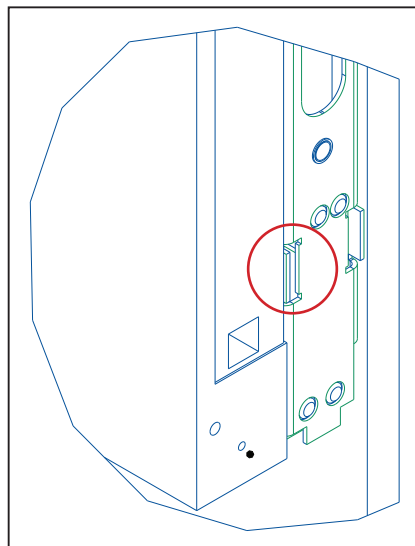

Figure 23: Ensure Alignment Tabs Do Not Protrude Past Display Edge

9. Repeat **Steps 1-3** for the remaining panels in the display. Start at the center of the next row up, install the columns, and then fill in from the bottom out from there. Refer to **Figure 24**.

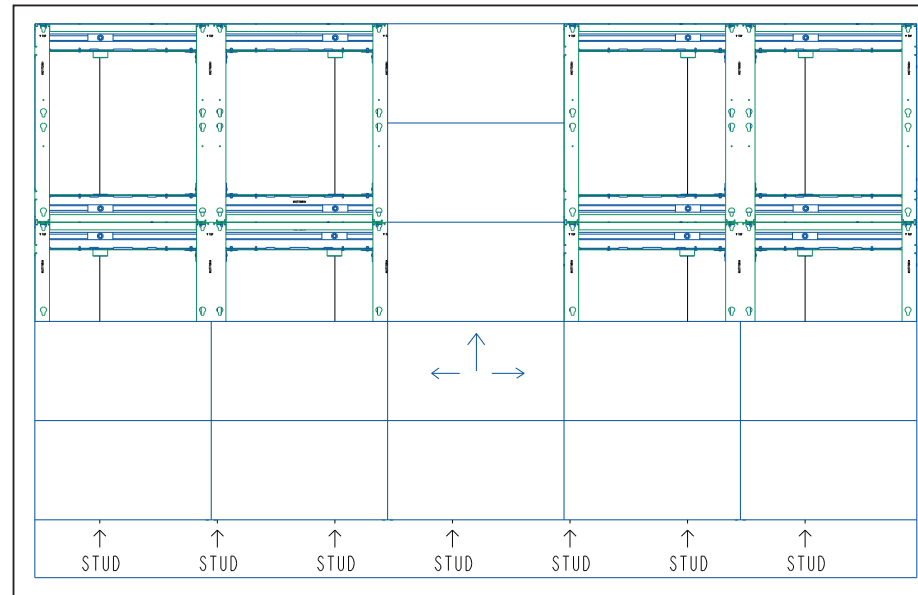

Figure 24: Install Remaining Panels in Display

10. Start securing panels together and to the frames at the top-center of the display after all panels are hanging on the frames.

11. Stitch the top row of panels together, ensuring the top and machined surfaces are flush to each other.

12. Tighten the M8 bolts so the panels are snug to the frame.

Note: Turn the M8 bolts counterclockwise to tighten and clockwise to loosen.

13. Continue to stitch panels together with stitch bolts center, down, and out. Tighten the M8 bolts to lock the panels in place. Refer to **Figure 25**.

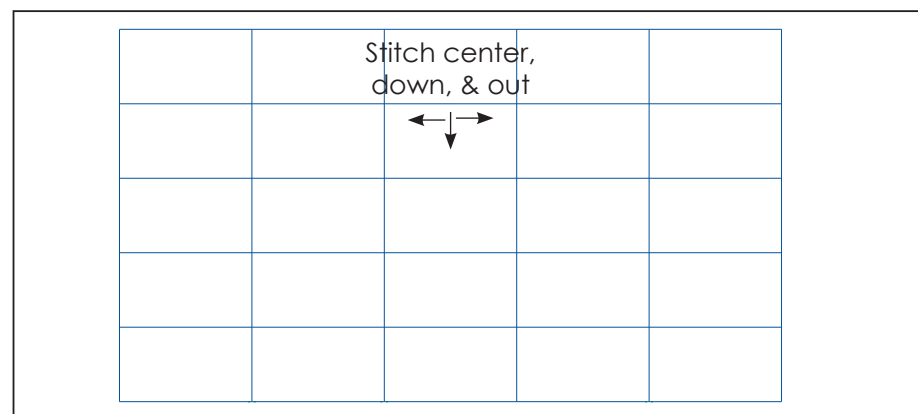

Figure 25: Stitch Panels Together

Adjust Corner Z-Position

Use M6 bolts to adjust the panel corner if a corner needs to be adjusted in the Z-position. Use a 5 mm hex key for either bolt type.

Push Panel Corner from Structure

1. Loosen the M8 bolt in the low panel corner.
2. Tighten the M6 bolt in the low panel corner until the face is flush with the adjacent panel.
3. Tighten the M8 bolt to lock the position into place.

Pull Panel Corner to Structure

1. Loosen the M6 bolt in the high panel corner until the face is flush with the adjacent panel.
2. Tighten the M8 bolt to lock the position into place.

When all panels are installed, go back across the faces of the corners of the panels to ensure the surfaces are flush. Fine-tune the Z-position as needed. Refer to **Figure 26**.

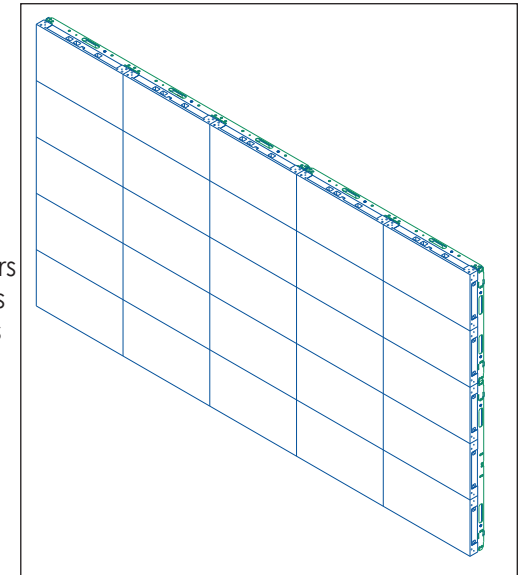

Figure 26: Ensure Panel Corner Faces Are Flush