

**Galaxy<sup>®</sup> AF-3500 Series  
46 mm**

**Installation & Operation Manual**

*DD1674581*

*Rev 5—11 July 2013*

**DAKTRONICS**

Complete the chart with specific information about this display, so the details are readily available when calling for service or replacement parts.

<b>Information Needed for Technicians and/or Customer Service</b>	
Location address of the display:	
Model number of the display:	
Version of software being used:	
Method of communication being used:	
Controller version used in the display:	

## **DAKTRONICS**

**Copyright © 2010-2013**

All rights reserved. While every precaution has been taken in the preparation of this manual, the publisher assumes no responsibility for errors or omissions. No part of this book covered by the copyrights hereon may be reproduced or copied in any form or by any means – graphic, electronic, or mechanical, including photocopying, taping, or information storage and retrieval systems – without written permission of the publisher.

*Galaxy® and Venus® are registered trademarks of Daktronics, Inc. Windows® is a registered trademark of Microsoft Corporation. IBM® is a registered trademark of IBM Corporation. Mate-N-Lok® is a registered trademark of AMP Company.*

# Table of Contents

---

<b>Section 1:</b>	<b>Overview of the Displays .....</b>	<b>1</b>
1.1	Display Details .....	1
<b>Section 2:</b>	<b>Mechanical Installation .....</b>	<b>3</b>
2.1	Display Identification .....	3
2.2	Pre-installation Checklist .....	4
2.3	Support Structure Requirements .....	4
2.4	Display Mounting .....	6
2.5	Ventilation Requirements .....	6
	Open Area Requirement for Rear Ventilation .....	6
	Natural Convection .....	7
	Fans .....	8
2.6	Optional Temperature Sensor Mounting.....	8
<b>Section 3:</b>	<b>Power Installation .....</b>	<b>9</b>
3.1	Conduit.....	9
3.2	Overview of Power Connection.....	9
3.3	Power Requirements .....	9
3.4	Grounding.....	10
3.5	Power Connection.....	11
3.6	Power Routing in the Display .....	12
<b>Section 4:</b>	<b>Signal Installation .....</b>	<b>13</b>
4.1	Overview of Signal Connection .....	13
4.2	Primary/Mirror Display Interconnections .....	13
4.3	USB to Ethernet Adapter.....	14
4.4	Setting the IP Address on the Display Controller .....	14
<b>Section 5:</b>	<b>Start-up Procedure .....</b>	<b>17</b>
5.1	Start-up Checklist.....	17
5.2	Start-up Sequence .....	17
5.3	Post Installation Checklist.....	18
<b>Section 6:</b>	<b>Maintenance .....</b>	<b>19</b>
6.1	Proper Ladder Use.....	19
6.2	Internal Display Access.....	20

6.3	Ventilation.....	21
6.4	Display Face Cleaning .....	22
6.5	Annual Inspection.....	23
<b>Section 7:</b>	<b>Diagnostics and Troubleshooting.....</b>	<b>25</b>
7.1	Controller Diagnostics.....	25
7.2	MLC Diagnostics .....	25
7.3	Temperature Sensor Diagnostic .....	26
7.4	Troubleshooting Display Problems .....	26
<b>Section 8:</b>	<b>Parts Replacement.....</b>	<b>31</b>
8.1	Parts Replacement List .....	31
8.2	Instructions for Replacing Parts .....	32
<b>Section 9:</b>	<b>Daktronics Exchange and Repair &amp; Return Programs.....</b>	<b>39</b>
9.1	Exchange Program .....	39
	Before Contacting Daktronics .....	39
9.2	Repair & Return Program .....	40
	Shipping Address .....	40
9.3	Daktronics Warranty and Limitation of Liability .....	40
<b>Glossary</b>	<b>.....</b>	<b>41</b>
<b>Appendix A:</b>	<b>Reference Drawings.....</b>	<b>43</b>
<b>Appendix B:</b>	<b>Temperature Sensor Installation .....</b>	<b>45</b>
<b>Appendix C:</b>	<b>International Installation .....</b>	<b>47</b>
<b>Appendix D:</b>	<b>Maintenance Log.....</b>	<b>49</b>
<b>Appendix E:</b>	<b>Daktronics Warranty and Limitation of Liability .....</b>	<b>51</b>

# Section 1: Overview of the Displays

---

This manual provides installation, maintenance, and troubleshooting information to ensure the optimal performance of the Daktronics Galaxy® AF-3500 Series 46 mm displays. Diagnostic information, parts replacement information, and a glossary are at the end of this manual.

## 1.1 Display Details

The Galaxy® model numbers are as follows:

AF-3500-RRxCCC-MM-R,A,RGB-XX		
AF-3500	=	Outdoor Galaxy display
RR	=	Number of pixel rows high
CCC	=	Number of pixel columns long
MM	=	Pixel pitch in millimeters
R,A,RGB	=	LED Color: R (Red), A (Amber), RGB (Full Color - Red, Green, Blue)
XX	=	SF (Primary) or 2V (Primary/Mirror)

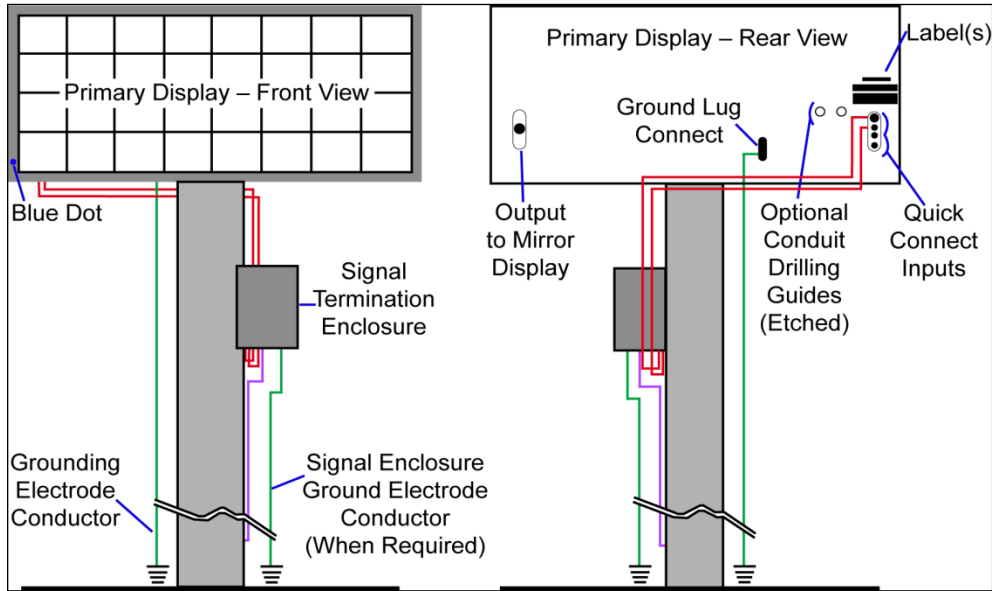
Displays come either as single-face or as 2V (Two-View) units. Standard display lengths greater than 192 pixels are single face only. For 2V units, refer to the first display as primary, and the second display as mirror. Modules are the “building blocks” of Daktronics displays. **Figure 1** shows a 46 mm 8 x 8 RGB module.

A typical display system consists of an IBM®-compatible computer running Venus® 1500 software for one or more displays. The Venus® 1500 software package runs on Windows® XP, or Windows Vista® Home/Professional operating systems. Refer to the Venus® 1500 Software Version 4 Operation Manual ([DD1370296](#)) for installation and operation of the Venus® 1500 software.

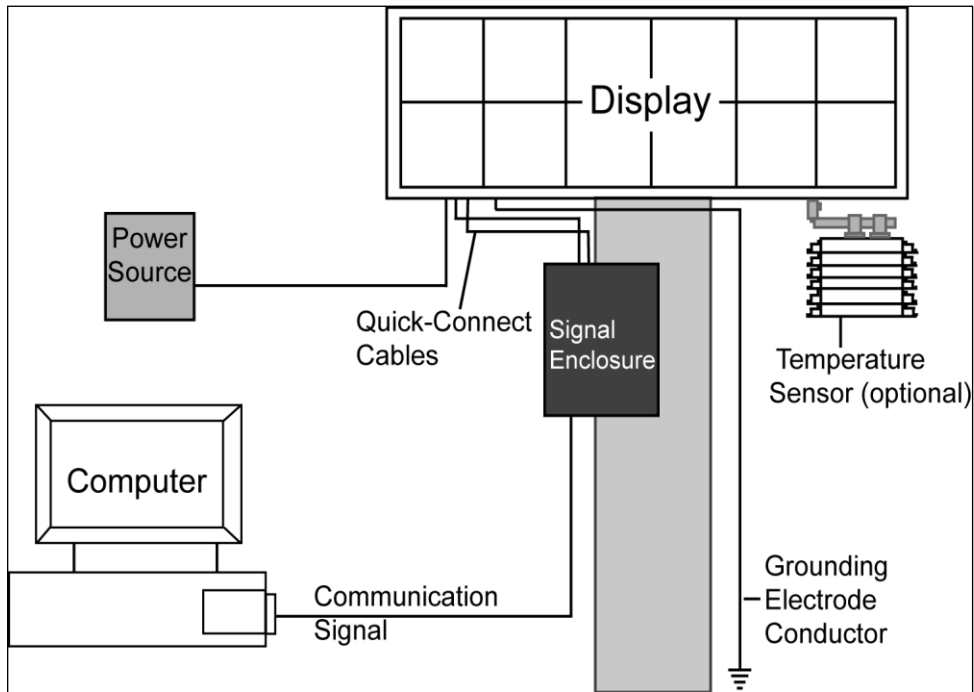


**Figure 1:** AF-3500 46 mm RGB Module

**Figure 2** shows the front and back views of a typical display. **Figure 3** shows a simplified diagram of basic display setup.



**Figure 2:** Display Components



**Figure 3:** Basic Display Setup

## Section 2: Mechanical Installation

Read **Section 2**, **Section 3**, and **Section 4**: before installing the display.

Daktronics' engineering staff must approve any changes that may affect the weather tightness of the display. Before making any modifications, submit detailed drawings of changes to Daktronics for evaluation and approval. Failure to do so may void the warranty.

**Note:** Do not drill holes in the display. Doing so will result in failure of internal components due to water intrusion. Daktronics is not responsible for installations or the structural integrity of support structures done by others. The customer must ensure a qualified structural engineer approves the structure and any additional hardware.

### 2.1 Display Identification

The following matrix shows the standard sizes for AF-3500 Series 46 mm displays. It shows which displays use front or rear ventilation, and which displays are single or sectional.

		Pixel Width													
		48	64	80	96	112	128	144	160	176	192	208	224	240	256
Pixel Height	8	Front Ventilated Single Section									Front Ventilated Sectional				
	16	Front Ventilated Single Section									Front Ventilated Sectional				
	24	Front Ventilated Single Section									Front Ventilated Sectional				
	32	Front Ventilated Single Section									Front Ventilated Sectional				
	40	Rear Ventilated Single Section									Rear Ventilated Sectional				
	48	Rear Ventilated Single Section									Rear Ventilated Sectional				
	56	Rear Ventilated Single Section									Rear Ventilated Sectional				
	64	Rear Ventilated Single Section									Rear Ventilated Sectional				

**Figure 4:** Single / Sectional Matrix

Galaxy 3500 series 46 mm displays that are 56 pixels high and above are shipped with side borders attached to the display cabinet. Top and bottom borders are shipped in a separate box and should be attached at time of installation. In order to maintain the integrity of display operation and ensure that it meets the required specifications, the side borders must remain attached to the display. It is recommended that the top and bottom borders be attached for aesthetic purposes, but can remain off if surrounding structure prevents them from being installed.

In order to comply with UL requirements, the UL mark must be visible after installation of all Galaxy displays. This label is typically located on the front of the display near the lower left corner.

## 2.2 Pre-installation Checklist

Verify the following before Installation	
	The display is in good condition after shipping and uncrating.
	The mounting structure will provide a straight and square mounting frame for the display.
	Height variation in any 4' (1.2 m) horizontal section must not exceed $\frac{1}{4}$ " (6.3 mm).
	Provide adequate support for the display so that the structure will not yield at any unsupported points after mounting.
	There is a 4" (10.2 cm) of unobstructed space above the display. This is required for eyebolt removal.
	There is clearance around the display. This is required for unobstructed airflow through the vents and fans, and for access to internal components.
	The display cabinet has no holes (accidental or intentional) that could allow water to enter the display.
	All display modules are fully latched into the display cabinet.

## 2.3 Support Structure Requirements

Daktronics expects the installer to use a safe and robust structure that meets all local codes to support the display.

Support structure design depends on the mounting methods, installation height, display size, and weight. Because every installation site is unique, Daktronics approves no single procedure for mounting Galaxy® displays.

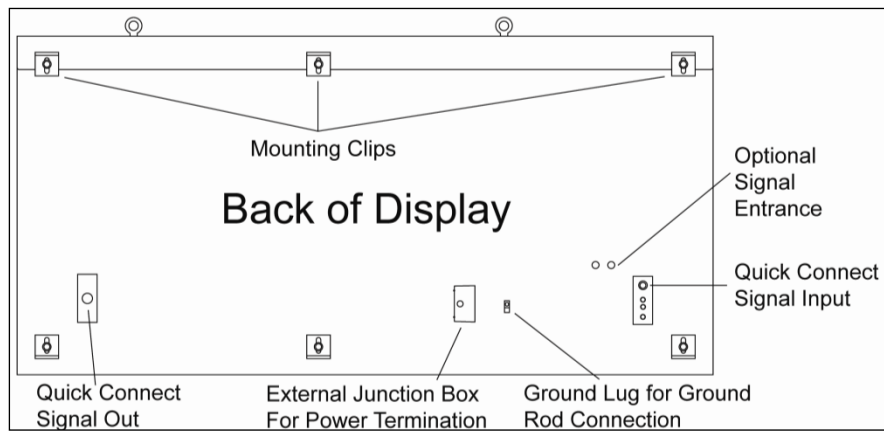
The information contained in this section is general information only and may not be appropriate for all installations. Refer to **Figure 2** and **Figure 3** for basic display setups.

Mounting plans need to take into account:

- The ventilation system. All display vents must remain completely unobstructed for airflow. Proper ventilation keeps the internal components from overheating. Refer to **Section 2.5**.
- The face-mounted light sensor.

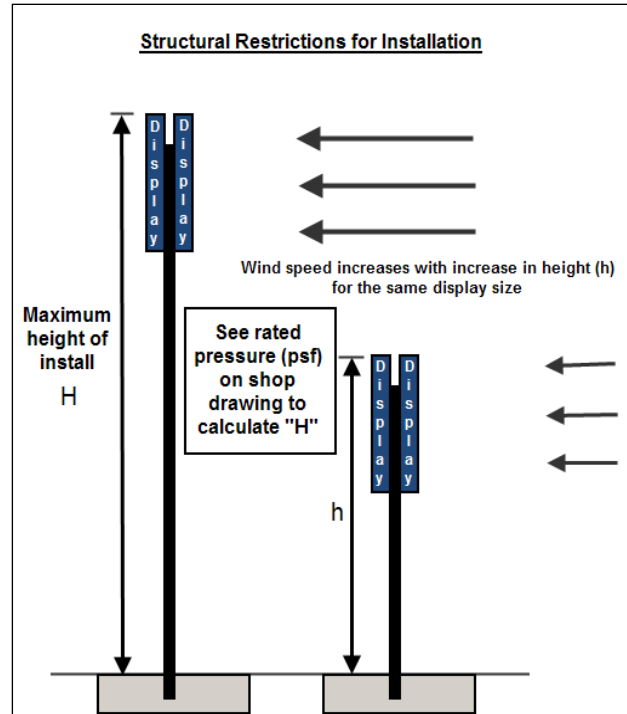


- The location of mounting clips, and the clearance needed for the power and signal terminations on the back of the display. Refer to **Figure 7**.



**Figure 5:** Back View of Typical Display

- Display height and wind load. Refer to **Figure 6** and the **Shop Drawing** that is included with the display.



**Figure 6:** Structural Restrictions for Installation

## 2.4 Display Mounting

To ensure structural integrity of the display cabinet, maintain a 90° angle between the cabinet and the lifting method.

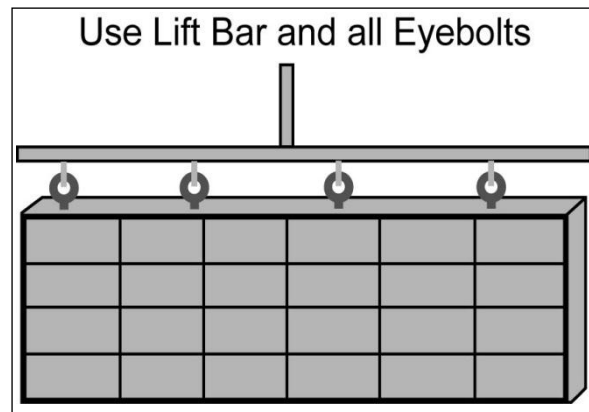
If damage occurs because of improper lifting procedures, the warranty will be void.

### General Mounting Procedure

1. Lift the display into position on the support structure. Refer to **Figure 7**.

Notes:

- Use all eyebolts to lift the display, as shown in **Figure 7**. Failure to do so may result in tear-off at hardware connections.
- Do not permanently support the display by the eyebolts.



**Figure 7:** Correct Lifting Procedure

2. Weld or use 1/2" grade-5 (or stronger) bolts and hardware to secure all of the clip angles to the support structure. Refer to the **Shop Drawing** included with the display.

**Note:** If using alternative mounting methods in place of clip angles, ensure that all bolt locations are used.

3. Refer to **Section 3**: for power routing and to the appropriate communication manual for signal connections to the display.
4. After installation is complete, carefully inspect the display for any holes that may allow water to seep into the display. Seal any holes with silicone.

## 2.5 Ventilation Requirements

Displays are equipped with ventilation systems to keep internal electrical components at safe operating temperatures. Depending on the size of the display, it will use either natural convection or fans. Pay special attention to the locations of intake and exhaust vents, as these vents must remain unobstructed to maintain safe operating temperatures.

### Open Area Requirement for Rear Ventilation

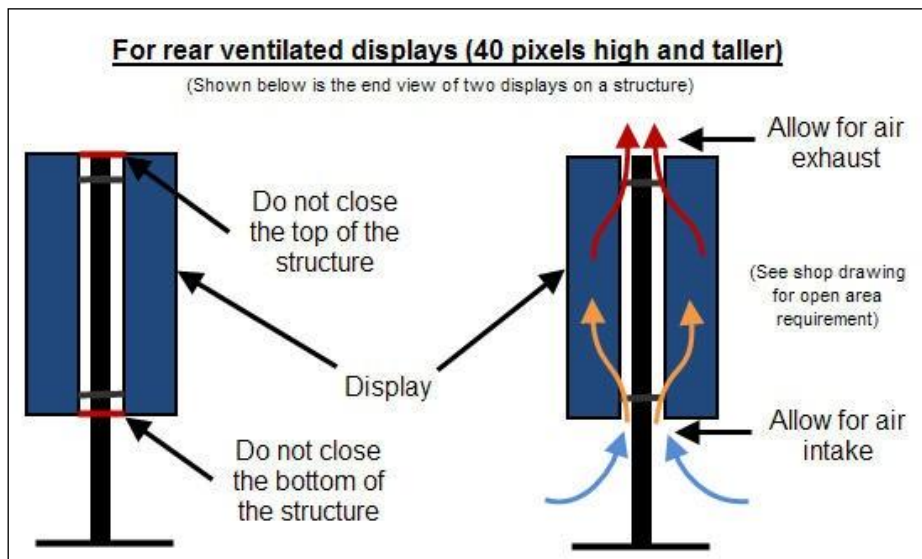
The open area requirement is the amount of open space needed behind a rear-ventilated display for proper ventilation. This area is different for each display. Refer to **Figure 8** for a general overview. For specifics on the open area requirement, refer to the **Shop Drawing** for the display.

## Natural Convection

RGB displays 40 pixels high and above use natural convection. RGB displays 40 and 48 high have intake vents in the front bottom, and exhaust vents in the rear top. RGB displays 56 high and above have intake and exhaust vents in the rear only.

Monochrome displays 48 high and above have intake and exhaust vents in the rear only. Refer to **Figure 8**.

**Note:** To maintain safe operating temperatures in the display, do not close off the top or bottom of the structure. The openings on the side of the structure do not help in cooling the display adequately. Openings on the side of the structure cannot be considered “open area.” If the natural airflow is blocked, the display will overheat and cause performance issues. Daktronics cannot be held responsible for performance issues that occur due to obstructed airflow.



**Figure 8:** Rear Ventilation

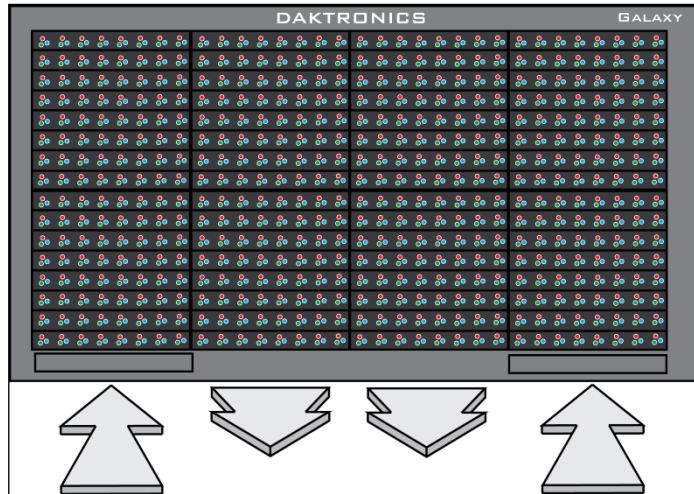
## Fans

Displays up to 40 pixels high use fans. Intake fans pull air through vents located on the bottom front of the display. If front ventilated, ensure the entire front of the display is exposed to allow for proper airflow.

Exhaust vents allow airflow through adjacent vents along the bottom front of the display.

Refer to **Figure 9**.

**Note:** When mounting the display, the entire front of the display must be exposed to allow for proper ventilation. Aesthetic shrouding (common in monument installations) is not advised.



**Figure 9:** Front Ventilation Airflow

## 2.6 Optional Temperature Sensor Mounting

Some displays use optional temperature sensors. Refer to **Appendix B:** for mounting and signal connections.

## Section 3: Power Installation

---

Only a qualified individual should terminate power and signal cable to a Daktronics display. Daktronics engineering staff must approve all proposed changes, or the warranty will be void.

### 3.1 Conduit

Daktronics does not provide conduit. Separate conduit must be used to route:

- Power
- Signal-in wires to the signal termination enclosure (when applicable).
- Signal-out wires (if not using the provided interconnect cable).

For power, displays come with either a J box, or a  $\frac{3}{4}$ " conduit access hole located near the lower-right corner, on the back of the display. For signal, displays come with either signal input quick-connects, or etched drilling guides for conduit.

### 3.2 Overview of Power Connection

- Terminate display power either at the J box, or internally, at the power termination panel. Refer to **Section 3.5** for wiring examples.
- Route power to the display through a fused disconnect switch, which can open all ungrounded power conductors. Refer to **Section 3.3** for additional information.
- Install the disconnect switch within sight of display maintenance personnel, unless it can be locked in the open position. Refer to **Section 3.3** for additional information.  
**Note:** Displays are equipped with circuit breakers that carry a **UL489** or **UL1077 (IEC 60947, VDE 660)** rating. These devices protect only the components within the display.
- Follow local code specifications when routing power conductors from the disconnect switch to the display.
- Connect the grounding conductor to the grounding lug on the back of the display. Refer to **Section 3.4** for additional information.
- For sectional displays, each section has its own power termination panel. Display lengths of 208, 224, 240, and 256 are two sections shipped as one; therefore, the installer will have to bring power to each assembled section.

### 3.3 Power Requirements

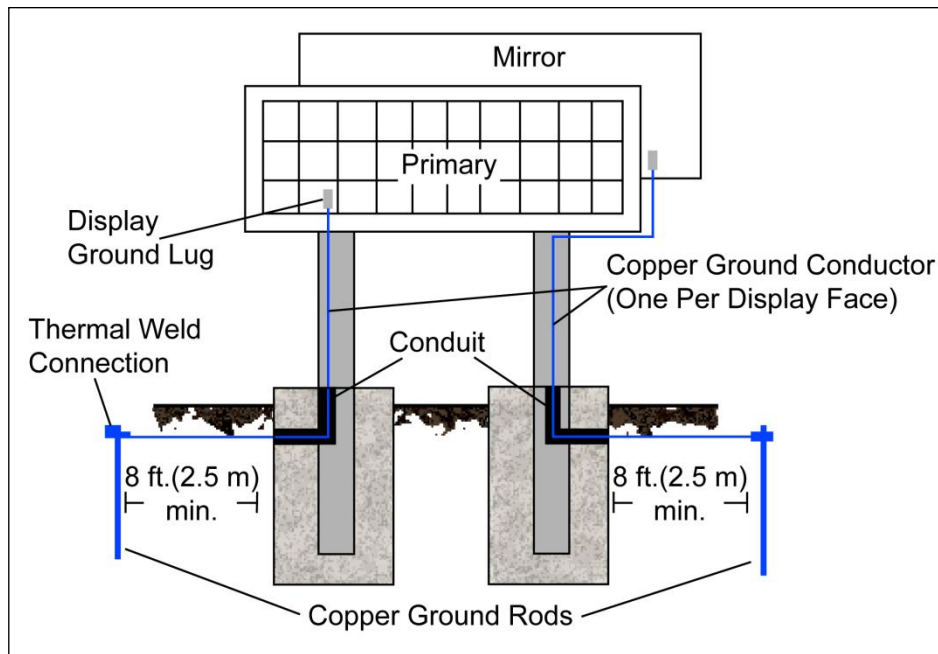
- Install the display according to applicable local and national electrical codes. This includes proper grounding and bonding of the display.
- Displays use single-phase power.
- Do not connect the displays to any voltage other than that listed on the Daktronics product label.
- Proper power installation is imperative for display operation.
- Refer to **Appendix B**: for the power specifications of the various display sizes.  
**Note:** For circuit conductors delivering power to a display, size them according to local and national electrical codes, so the power distribution system delivers full load power to the display while maintaining a voltage within five percent of the nominal utility voltage.

## Main Disconnect

- Daktronics requires using a disconnect switch so that all ungrounded conductors can be disconnected near the point of power connection.
- Place the disconnect switch in direct line of sight from the display, unless it can be locked in the open position. This ensures power remains off while service personnel work on the display.

## 3.4 Grounding

- Ground displays according to the provisions outlined in local and national electrical codes. Install with the ground and neutral conductors provided.  
**Note:** Do not connect neutral to ground at the disconnect switch or at the display. This violates electrical codes and voids the warranty.
- Connect the display system to the earth ground, as shown in **Figure 10**. Proper grounding protects the equipment from electrical disturbances and lightning.
- Daktronics requires a resistance to ground of 10 ohms or less. Failure to ground the display properly voids the warranty.



**Figure 10:** Correct Grounding

### Important Points about Grounding

- **Resistance to ground 10 ohms or less:** This is required by Daktronics for proper display performance. If the resistance to ground is higher than 10 ohms, install additional grounding electrodes to reduce the resistance. The grounding electrode should be installed within 25' (7.6 m) of the base of the display and must be connected to the ground lug on the back of the display. Refer to **Figure 10**.
- **Follow local and national codes:** The material of an earth-ground electrode differs from region to region and for conditions present at the site. Consult any local and national electrical codes that may apply.

- **Support structure cannot be used as an earth-ground electrode:** Daktronics does not recommend using the support structure as an earth-ground electrode; concrete, primer, corrosion, and other factors make the support structure a poor ground.  
**Note:** The support structure may be used as an earth-ground electrode only if designed to do so. A qualified inspector must approve the support structure and grounding methods.
- **One grounding electrode for each display face:** The grounding electrode is typically one grounding rod for each display face. Other grounding electrodes as described in any local and national electrical codes may be used.

### 3.5 Power Connection

For most displays, power terminates externally at the J box. However, larger displays require internal power termination at the power termination panel.

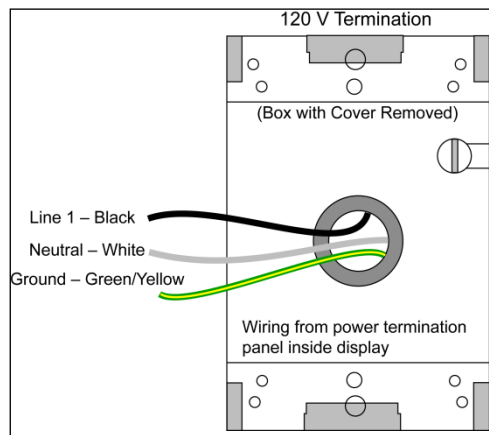
#### For Displays with an External Power Termination J box

To terminate hot, neutral, and ground wires at the J box:

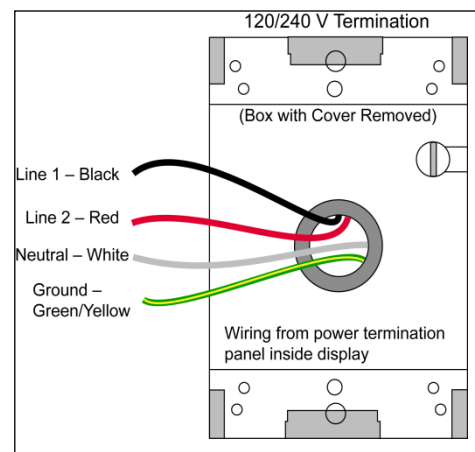
1. Route the power cable through conduit to the rear of the display, and into the power termination J box. The J box contains  $\frac{3}{4}$ " threaded conduit fittings.
2. The J box contains two or three wires, plus a ground coming from the interior of the display. These wires pre-terminate at the power termination panel inside the display. Refer to the following table for wire colors:

120 VAC	120/240 VAC
Line 1 – Black	Line 1 – Black
	Line 2 – Red
Neutral – White	Neutral – White
Ground – Green/Yellow	Ground – Green/Yellow

3. Inside the external J box, use wire nuts to connect the power wires to the wires coming from the display interior. Refer to **Figure 11** for 120 V AC and **Figure 12** for 120 / 240 V AC.



**Figure 11:** 120 V J box Termination

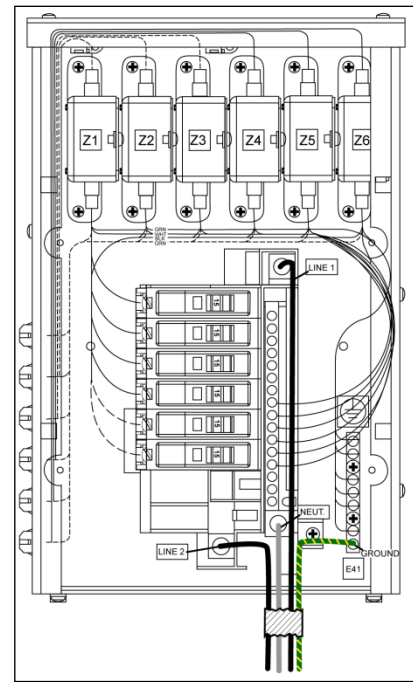


**Figure 12:** 120 / 240 V J box Termination

## For Displays with Internal Power Termination

To terminate single-phase power to the internal power termination panel:

1. Open the display as explained in **Section 6:** and locate the power termination panel.
2. Route the cable through conduit to the back of the display. Use the  $\frac{3}{4}$ " knockout for access, careful not to damage internal components.
3. Connect the neutral wire to the neutral lug and the live wires to the Line 1 and Line 2 lugs.
4. The ground wire connects to the grounding bus bar. Refer to **Figure 13**.

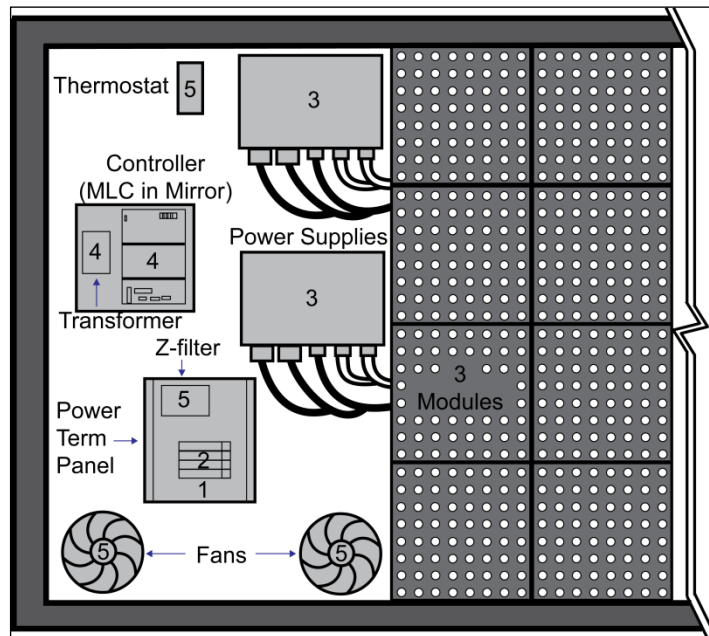


**Figure 13:** Single-phase 6-breaker Domestic Panel

## 3.6 Power Routing in the Display

The following list is a summary of power routing. The list refers to the numbers in **Figure 14**.

1. Power terminates internally to the power termination panel (either directly or via the rear-mounted J box).
2. Power routes through the circuit breakers and the Z-filter in the power termination panel.
3. Power routes through filters to the power supplies, which provide power to the modules.
4. Power travels through the transformer, which steps down power to the appropriate voltage for the controller (or MLC in a mirror display).
5. Power routes through a filter to the thermostat and the fans. The thermostat activates the fans. **Note:** Power supplies are set to the proper voltage via the V adjust harness that is connected to the nearest module.



**Figure 14:** Power Flow Summary



## Section 4: Signal Installation

For specific details on installing communications, consult the quick guide and manual included with the communication equipment. Refer to the table below for the standard communication types and their corresponding manual number. These are the standard communication types. Each site is unique and may include additional equipment. If problems arise, contact the display's service company or Daktronics Customer Service.

Communication Type	Communication Manual	Communication Quick Guide
Ethernet	<a href="#">DD1417609</a>	<a href="#">DD1417573</a>
Fiber Ethernet	<a href="#">DD1417611</a>	<a href="#">DD1417581</a>
Wireless Ethernet Bridge	<a href="#">DD1417615</a>	<a href="#">DD1417586</a>
Wi-Fi	<a href="#">DD1417619</a>	<a href="#">DD1417592</a>
USB to Ethernet Adapter	N/A	<a href="#">DD1790707</a>

### 4.1 Overview of Signal Connection

- Refer to the communication manuals for methods of signal termination.
- Route signal cable to the signal termination enclosure. Ground the enclosure to an isolated earth ground connector (when required).
- Route signal cable through conduit into the enclosure. Use  $3/4$ " conduit for the knockouts on the enclosure.
- Route signal quick-connect cables through conduit, from the enclosure to the display. Optionally, you can route signal through the display pole; however, do not route signal through the display pole if routing power through the display pole.

**Note:** Daktronics strongly recommends that the quick-connect cables be secured to protect them from weather or vandalism.

### 4.2 Primary/Mirror Display Interconnections

- If this display is a two-sided primary/mirror display, a 20' quick-connect cable will be provided to connect the signal between the two faces. This cable cannot be lengthened. Refer to **Figure 15**.
- Secure the excess cable to the support structure to prevent weather damage or vandalism.



**Figure 15:** Primary/Mirror Quick-connect Cable

### 4.3 USB to Ethernet Adapter

A USB to Ethernet adapter is included with the display and can be used to bypass network configuration in situations where simple point-to-point communication is required. The adapter creates a secondary network that is dedicated to communication with the display, but network operation is still enabled through the primary network.

The USB to Ethernet Adapter can be used in conjunction with communication kits supplied with the display. Refer to [DD1790707](#) for more information regarding the adapter.

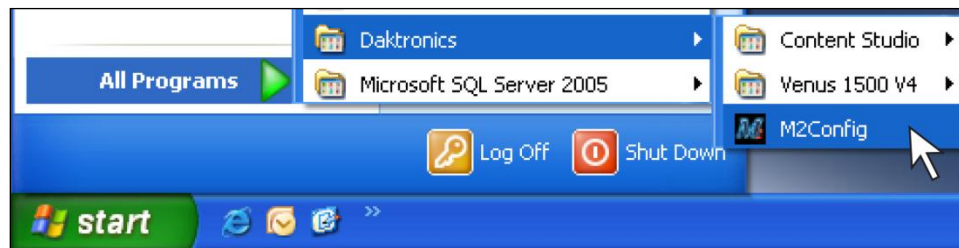
### 4.4 Setting the IP Address on the Display Controller

Galaxy AF-3500 display controllers are set to a default IP address of 172.16.192.25 prior to shipping. This address can be changed to an address specific to the local display network. To obtain an appropriate IP address for the display, contact the network administrator.

In order to complete the following directions, the display will need to have power and M2Config will need to be installed on the computer. M2Config can be downloaded at [dakfiles.daktronics.com](http://dakfiles.daktronics.com) - /downloads/venus1500/utills/M2\_Config. Communication with the display controller will be necessary and can be done through the purchased communication method or directly to the display controller using a Cat5 cable.

Display power must be “ON” to complete this configuration.

1. Set the computer’s IP address to 172.16.192.20 and the Subnet Mask to 255.255.0.0.
2. To open M2Config, click **Start>All Programs>Daktronics>M2Config**, or double-click the shortcut on the desktop. Refer to



**Figure 16:** Open M2Config

3. Configure the communication method to connect to the display by clicking **Network > Configure Connection**, or by clicking the **Configure Connection** icon.

- The M2 Configuration Studio has two folders under the Configuration tab. Click the

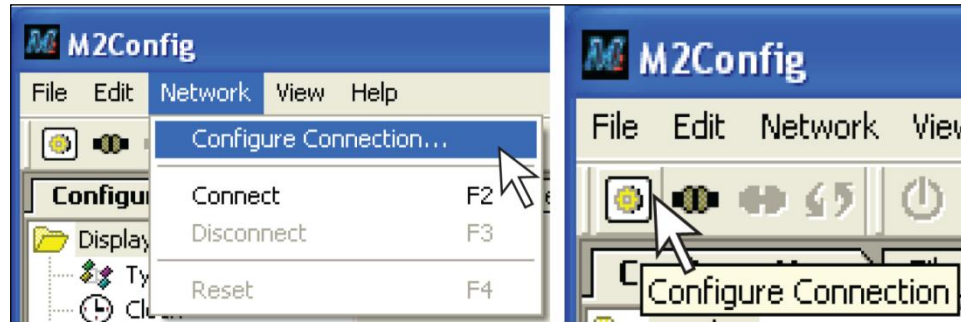


Figure 17: Configure Connection

**Communications**  
folder.

- Use the following information for your display to configure a direct connection:
  - Type: TCP/IP
  - Address: 1 (Refer to address dials on controller for actual setting)
  - IP Address: 172.16.192.25

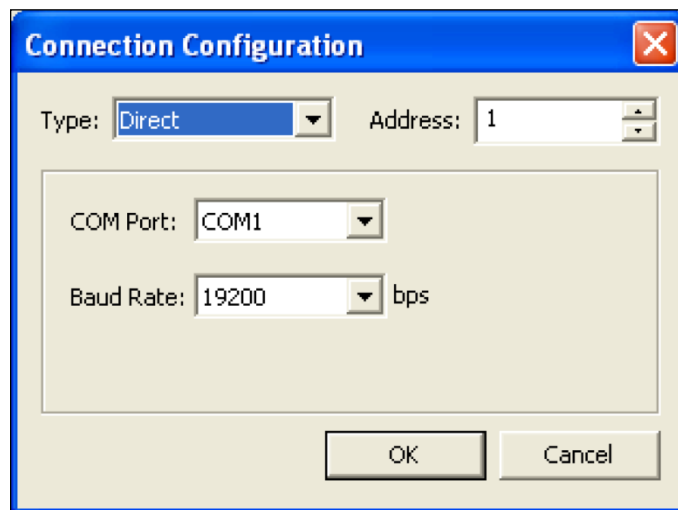


Figure 18: Connection Configuration

- Click **Network** > **Connect**, or click the **Connect** icon to connect to the display.

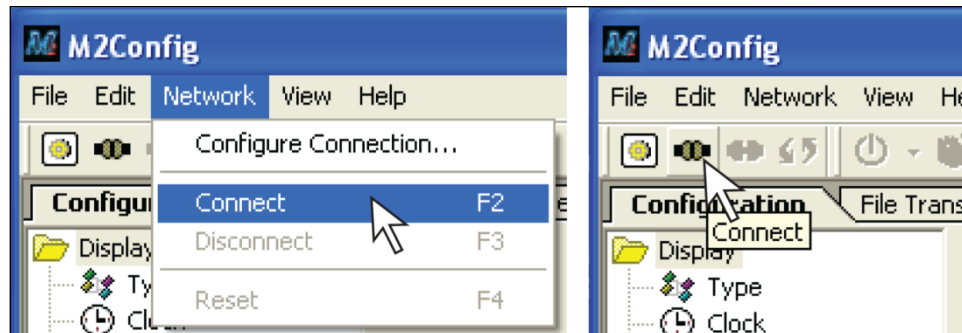
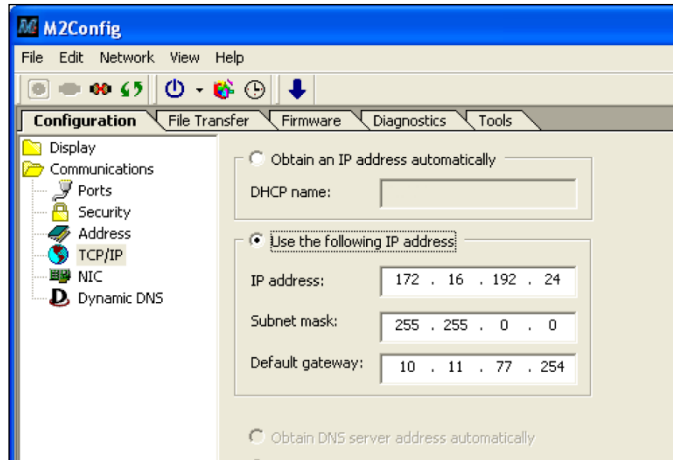


Figure 19: Connect

- After connecting to the controller, select the **Communications** folder on the left side of the screen then select **TCP/IP**:

- Input the IP address, Subnet mask, and Gateway as provided by the Network Administrator.



**Figure 20:** Use the following IP address

8. Choose **File > Set Configuration** to upload the new IP address to the display.
9. When the warning appears, select OK and wait for display to reboot. Close M2Config.



**Figure 21:** Set Configuration

For further information on using a TCP/IP network with the display, refer to the Venus 1500 Help file.

## Section 5: Start-up Procedure

---

Before starting up the display, review this checklist to ensure that all parts are ready to operate correctly. **Figure 3** shows the basic display components referred to in each step.

### 5.1 Start-up Checklist

	Confirm power is correctly connected to the display.
	Ensure a main disconnect switch is used to control power.
	Inspect all circuit breakers (internal and external) for sufficient marking and size.
	Confirm adequately installed grounding. Each display face must have a separate earth-ground conductor with a resistance of 10 ohms or less.
	Ensure proper installation of external communication equipment (signal enclosure, client radio, etc.).
	Inspect signal connections at the control computer.
	Inspect signal connections at the display. Inspect signal connections between displays when necessary.
	Confirm correct configuration of control computer. Refer to the Venus® 1500 Help File's Configuration section for correct setup.
	Inspect peripheral equipment (temperature sensor, etc.) for proper installation.

### 5.2 Start-up Sequence

After turning on the display, an initialization sequence runs. Refer to the table below for information it shows.

**Note:** The Xs refer to numbers that may vary for each display, such as the hardware address.

Topic	Information Shown
Controller Type	M3
Product Name	Galaxy
Display Size	#Rows x #Columns
Shading/Color Depth	4096 (Mono) or 68B (RGB)
Bootloader Version	OS X.XX
Firmware Number	DD1425608
Firmware Revision	Rev X.XX
Hardware Address	HW:XX
Software Address	SW:XX
IP Address:	(default) IP:172.16.192.25
Subnet MSK:	(default) MSK: 255.255.0.0
COM1 Configuration	C1: 115200
COM 2 Configuration	C2: RTD
Socket 3001	IP 3001: 115200
Socket 3002	IP 3002: RTD
Line Frequency	CLK: AUTO (60)
Display Description	Galaxy #Rows x #Columns

If there are no messages running on the display after the sequence is complete, the display will go blank. A single pixel flashes in the lower-right corner of the display to show that the display has power, but no messages are currently running.

### 5.3 Post Installation Checklist

After starting the display:

	If the display uses ventilation fans, ensure they are operational.
	Inspect all intake vents and exhaust vents for obstruction.
	Confirm proper communications from the control computer to the displays.
	Ensure proper communications between display faces when applicable.

## Section 6: Maintenance

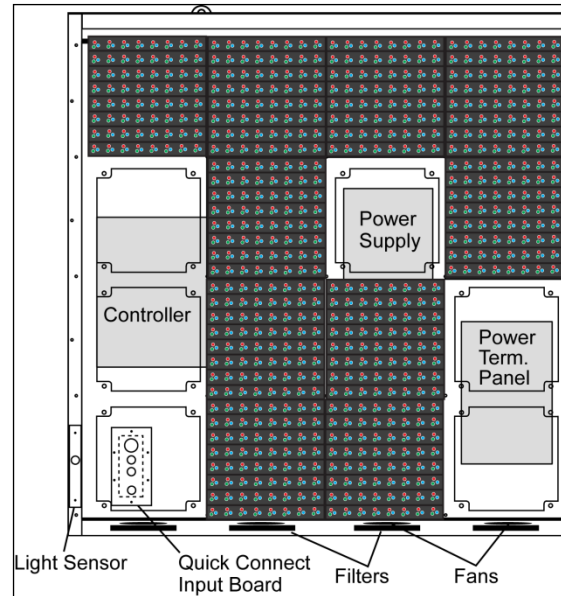
Only a qualified individual should service internal electronic components. Turn off power before performing repair or maintenance work.

Daktronics Galaxy® AF-3500 Series 46 mm displays are front-access only. This means that access to the internal components is gained by removing the front modules of the display. **Figure 22** shows the approximate location of internal components.

### 6.1 Proper Ladder Use

A ladder can be used to access displays, although it is not preferable. If a ladder must be used, do not place the ladder directly against the display face. The pressure from the two ladder ends, even when covered with pads, is too concentrated and can damage the LEDs and louvers.

Instead, use a padded or carpeted board across the top of the ladder to distribute the weight of the ladder evenly when placed against the display face. The padded board should be wide enough to spread the weight of the ladder across a minimum of two modules.



**Figure 22:** Internal Components in the Left Side of the Display



**Figure 23:** Example Ladder Board

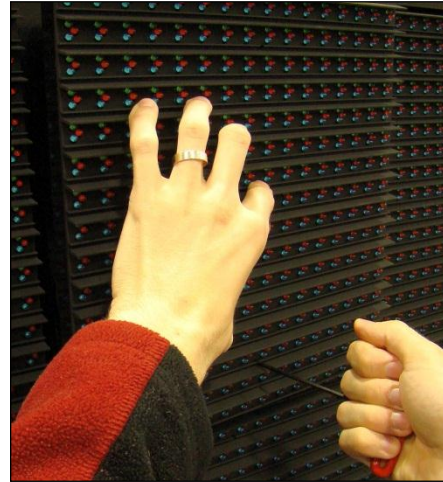
## 6.2 Internal Display Access

At times, the display may need to be opened for maintenance, or for troubleshooting. Follow this procedure safely and properly to access the interior of the display.

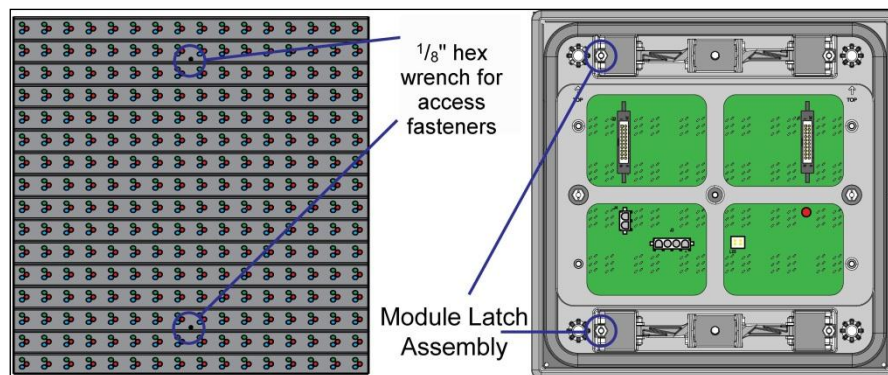
1. Disconnect power to the display.
2. Locate the latch access fasteners on the module. Refer to **Figure 24**. Locate one centered near the top, and the other centered near the bottom.
3. With a  $1/8$ " hex wrench, turn the latch access fasteners a quarter turn counter-clockwise.
4. Gently pull the module far enough forward to reach behind the module.

**Note:** Do not allow the module to hang by its power and signal cables.

5. Unplug the power cables, squeeze the tabs on the sides of the plug head, and pull out.
6. Disconnect the two ribbon cables from the module by spreading the side tabs, and then lifting the cable head from the jack. Note the cable connection locations to ensure proper reconnection.
7. When ready to reinstall the module, reconnect the cables to the module. Tightly push the tabs against the cable head. Carefully push the ribbon wires back into the cabinet so they are clear of the module edges.
8. Place the module in its proper location.
9. Check that the weather stripping is in place. To prevent water from entering the display, the weather stripping on the back edge of the module must be in good condition.
10. Latch the module at both the top and bottom locations by turning the hex wrench clockwise a quarter turn. Fully engage the module latches to create a watertight seal around the edge of the module.



**Figure 24:** Removing a Module



**Figure 25:** Module Latch Locations



#### Notes:

- The weather stripping on the back edge of the module must be in good condition to prevent water from entering the display.
- The module latches must be fully engaged to create a watertight seal around the edge of the module. The module should be firmly seated against the display when the latches are fully engaged.

## 6.3 Ventilation

### Frequency of Inspection

Check the fans or filters every time you open the display, or once every three months, at a minimum. Check more often if the display is located in a dusty or harsh environment, such as along a gravel road.

The frequency of inspection will vary greatly from display to display, as no two display setups are the same. Daktronics advises customers and service technicians to use their own discretion when establishing an inspection schedule.

### Filters

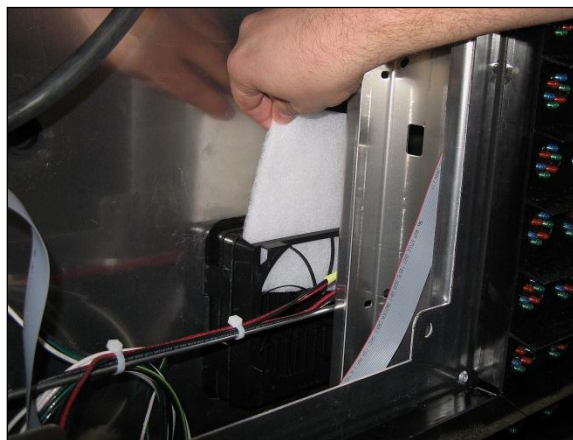
#### *For Displays Using Natural Convection*

Displays 40 and 48 pixels high use both rear vent panels and front filter trays.

Follow the instructions in *For Displays Using Fans* to service the front filters. Displays 56 and 64 pixels high are rear ventilated.

To service the filters in the vent panels:

1. Remove the module that is front of the vent panel. Refer to **Section 6**: for internal display access. Refer to **Figure 26**.
2. Pull the filter upwards and out.
3. Inspect the filter and clean it if needed.
4. Reinsert the filter in the vent panel.
5. Reinsert the module.



**Figure 26:** Service Filters in Vent Panels

#### *For Displays Using Fans*

A filter tray is located below each intake fan. Inspect the filters every time you inspect the ventilation system or fans. Clean or replace filters when necessary.

1. To access the filters, locate the tab on the bottom front of the tray.
2. Press upward firmly and pull outward.

3. Clean filters with water, or compressed air blown through the filter opposite of normal airflow (no greater than 60 psi and at least 6" away).
4. Allow filters to dry before returning them to their trays.

Daktronics encourages users and service technicians to use their own discretion when deciding whether to clean or replace the filters.

**Note:** Air draws upward through the filter. Be sure to check the bottom of the filter as this will be the side that requires cleaning.

### **Fan Blades**

If the display has fans, check the fan blades for dirt and debris. If necessary, clean them and the inside of the display. Cleaning the blades ensures fan efficiency and proper cooling. Spin the fan blades with a pen or pencil to ensure that the bearings are free, and that the fan is in balance.

There is also a smaller fan located on the controller enclosure cover that should always be running.

## **6.4 Display Face Cleaning**

### **Wet Cleaning Process**

**Tools required:**

- Bucket and cold water
- Non-abrasive, non-petroleum-based detergent
- Light-/medium-duty cleaning brush
- Soft terry cloth towels

To clean the display:

1. Turn off the power to the display.
2. Mix a mild, non-abrasive, non-petroleum-based detergent and cold water – one ounce of detergent to one gallon of cold water.
3. Saturate a light-/medium-duty cleaning brush with the soapy water.
4. Wash the display from top to bottom, using horizontal brush strokes to loosen and remove dirt and grime. Use light pressure so as not to damage the LEDs. Clean only the area safely reachable from a lift or stage, and then move on to the next section of modules.
5. Rinse the display face with generous amounts of cold water under low pressure. Use a spot-free rinse agent to reduce water spots.
6. Use soft, dry terry cloth to dry and remove any excess water. Take care not to damage LEDs by catching the cloth on them.
7. Allow the display to air-dry completely for 12 hours before applying power to the display.

## Dry Cleaning Process

1. Turn off power to the display.
2. Rub a dry, soft terry cloth horizontally across each row of LEDs.
3. Work from top to bottom. Clean only the area safely reachable from a lift or stage, and then move on to the next section of modules. Take care not to damage LEDs or the plastic louvers by catching the cloth on them.

## 6.5 Annual Inspection

Perform a yearly inspection of the display to maintain safe and dependable operation. Open the display to inspect the cabinet interior and the components. Refer to **Section 6:** for directions to access the interior.

1. Tighten or replace any loose fasteners.
2. Vacuum or carefully wipe away dust and debris around the vents / fans and inside the cabinet.
3. Check for water intrusion or stains. Replace weather stripping. Tighten module latches, place silicone sealant around areas where water might enter, and replace damaged electronic components as necessary.
4. Check the paint for cracking and peeling and touch up with rust resistant enamel as necessary.
5. Inspect the footings, tie points, and ground rods for corrosion, and make sure the structural integrity and grounding connections are intact.

Use the log provided in **Appendix D:** to track maintenance, and to help determine a maintenance schedule specific to the individual display.



# Section 7: Diagnostics and Troubleshooting

**Important Notes:** Disconnect power when servicing the display. Only qualified service personnel should service internal electronic components.

## 7.1 Controller Diagnostics

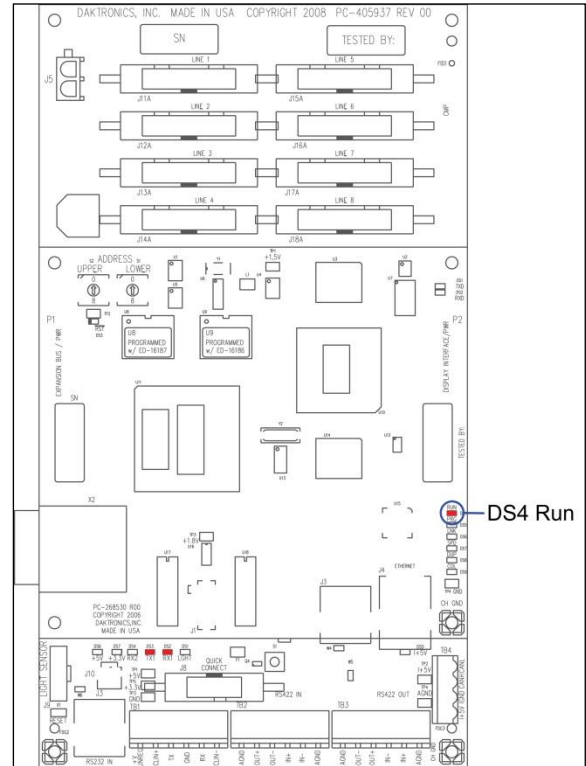
The controller is the “brains” of the display. It receives communication from the computer and sends information to the modules. The controller is located in the lower left area of displays. Refer to **Figure 22**. LEDs on the controller show whether the power and communication signal are working properly.

Mirror displays do not contain a controller. Instead, they have a multi-line controller (MLC), which helps relay information from the primary controller.

To access the interior of the display, refer to **Section 6**. Remember to disconnect power to the display before accessing the interior. Remove the modules; inspect the wires for safety, and then turn on power to view the diagnostic LEDs.

Refer to **Figure 27** for an example of a Galaxy® display controller. Essential diagnostic LED:

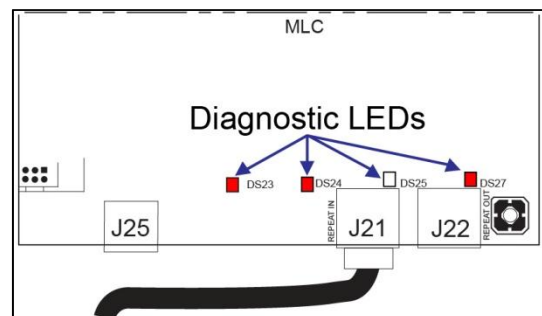
- The **DS4 Run** LED shows the controller’s operational status. This LED will flash once per second to indicate that the controller is functioning properly.



**Figure 27:** Controller Diagnostics

## 7.2 MLC Diagnostics

The Multi-Line Controller (MLC) unit contains four red diagnostic LEDs. When properly connected to the primary display, the LED labeled DS25 will be off and the other LEDs will be on, as shown in **Figure 28**.

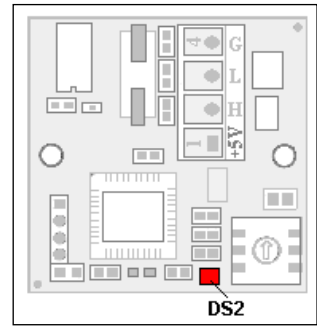


**Figure 28:** MLC Diagnostic LEDs

### 7.3 Temperature Sensor Diagnostic

If the display includes a temperature sensor, the temperature sensor board will also provide diagnostic information. The temperature sensor board is located inside the temperature sensor housing which is located near the display. Refer to **Figure 3**. The sensor board diagram in **Figure 29** shows the red diagnostic LED (DS2) near the bottom edge of the component. This LED will flash at variable rates when transmitting temperature information and provides evidence that the unit has power.

Refer to **Appendix B**: for temperature sensor mounting and connections.

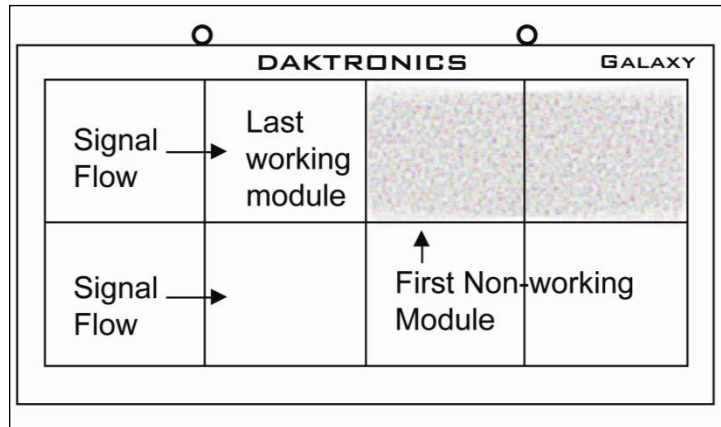


**Figure 29:** Temperature Sensor Board

### 7.4 Troubleshooting Display Problems

This section contains general display problems and related troubleshooting solutions. The list does not include every possible problem or solution, but does represent common situations and simple steps to resolve them.

Troubleshooting may require removal and replacement of modules. Refer to **Section 6**: for more information.



**Figure 30:** Modules Not Working

<b>Display Problems</b>	
<b>Blank display seen after boot-up</b>	<ul style="list-style-type: none"> <li>• A blank display is normal after the boot-up procedure. When finished, the display will go blank except for a flashing pixel in the lower-right corner. This indicates the display is waiting for a message.</li> </ul>
<b>One or more LEDs are not lighting</b>	<ul style="list-style-type: none"> <li>• Check/replace the ribbon cables on the module.</li> <li>• Replace the module.</li> </ul>
<b>One or more LEDs on a single module will not turn off</b>	<ul style="list-style-type: none"> <li>• Check/replace the ribbon cables on the module.</li> <li>• Replace the module.</li> </ul>
<b>A section of the display is not working</b>	<ul style="list-style-type: none"> <li>• Check/replace ribbon cables from the last working module in the row to the first non-working module next to it. Refer to <b>Figure 30</b> for an example.</li> <li>• Check the back of the modules to see that the power LEDs are on.</li> <li>• Make sure the power cable to the module is connected.</li> <li>• Move or replace the first non-working module with the one on the left of the non-working section.</li> <li>• Move or replace the first module to the left of the non-working modules.</li> </ul>
<b>One row of modules is not working or shows a distorted message</b>	<ul style="list-style-type: none"> <li>• Check/replace the ribbon cables to and from the first non-working module.</li> <li>• Check for bent pins on the jack going to a non-working module.</li> <li>• Move or replace the modules that show distorted text.</li> <li>• Move or replace the first module to the left of the non-working module.</li> </ul>
<b>A column of the display does not work</b>	<ul style="list-style-type: none"> <li>• Check that the power cable plugs into the module in the column.</li> <li>• While power is on, look at the back of the malfunctioning modules to see if the diagnostic LED is off, implying a power supply problem.</li> <li>• Verify power to the power supply.</li> </ul>
<b>Entire display fails to work</b>	<ul style="list-style-type: none"> <li>• Check the breakers in the building connected to main power source.</li> <li>• Check the breakers in the power termination panel.</li> <li>• Check the diagnostic LEDs on the controller for Power and Run. Refer to <b>Section 7.1</b> for more information.</li> <li>• Check/replace the ribbon cable from the controller to the modules.</li> <li>• Verify proper use of the software by checking the software manual.</li> </ul>
<b>Section of display looks dim</b>	<ul style="list-style-type: none"> <li>• Check V Adjust cable on module is plugged in.</li> </ul>

<b>Brightness problems</b>	
<b>Display is stuck on bright or dim</b>	<ul style="list-style-type: none"> <li>• Check Manual/Auto dimming in Venus 1500 software. If not set to automatic, refer to the Venus 1500 software manual (<a href="#">DD1370296</a>) for more information.</li> <li>• Check the light sensor cable and wiring for secure connections.</li> <li>• Check the light sensor lens for obstructions (lower left edge, front of primary cabinet).</li> <li>• Replace the light sensor assembly.</li> </ul>
<b>Display is too bright at night</b>	<ul style="list-style-type: none"> <li>• Set the Dimming Schedule. Refer to the Venus 1500 software manual (<a href="#">DD1370296</a>) for more information.</li> </ul>

<b>Message problems</b>		
<p><b>Message only shows up on one side of the display</b></p> <p>Determine if the displays are set up as two primary displays or one primary and one mirror display.</p>	<b>Primary/Primary Display</b>	<ul style="list-style-type: none"> <li>• Verify that two different addresses are set up for these two primary displays. Refer to the Venus 1500 software manual for more information.</li> <li>• Verify that two different addresses are set on the controllers.</li> <li>• Send a different message to each display separately by clicking on that display name in the list.</li> </ul> <p><b>Note:</b> With two controllers, messages may not always run simultaneously.</p>
	<b>Primary/Mirror Display</b>	<ul style="list-style-type: none"> <li>• Check interconnect cable between displays.</li> <li>• Verify that the cable firmly plugs into both cabinets.</li> <li>• Check that the cable and plugs are in good condition.</li> <li>• Check that the MLC in the mirror display has power.</li> </ul>

<b>Temperature problems (For displays with a temperature sensor installed)</b>	
No temperature showing on the display	<ul style="list-style-type: none"> <li>• Ensure proper temperature sensor installation in order to show the current temperature.</li> <li>• Refer to the Venus 1500 software manual (<a href="#">DD1370296</a>) for more information.</li> </ul>
Temperature shown is too high or too low	<ul style="list-style-type: none"> <li>• For greater accuracy, adjust the temperature on the display either up or down.</li> <li>• Refer to the Venus 1500 software manual (<a href="#">DD1370296</a>) for more information.</li> </ul> <p><b>Note:</b> Repeat the above steps for each primary display that shows the temperature.</p>
Temperature always reads -196F/-127C degrees	<ul style="list-style-type: none"> <li>• Check the temperature sensor cable connections.</li> <li>• Look for bent pins on connectors.</li> <li>• Check that the temperature sensor is set to address 1.</li> <li>• Ensure the sensor has power by checking that the diagnostic LED is blinking.</li> </ul>



	<ul style="list-style-type: none"> <li>• Replace the temperature sensor.</li> </ul>
--	-------------------------------------------------------------------------------------

<b>Testing displays</b>	
Start and stop the test pattern	<ul style="list-style-type: none"> <li>• Refer to the Venus 1500 software manual (<a href="#">DD1370296</a>) for more information.</li> </ul> <p><b>Note:</b> Perform this procedure for each primary display.</p>

### **Before Calling for Help**

1. Turn off the power breaker switch. Wait a few minutes and turn it back on. Watch the display to make sure that the initialization sequence runs.
2. Once the sequence is complete, verify whether the issue is resolved.
3. Refer to **Section 4:** of this manual.
4. Call the service technician or Daktronics Customer Service at 866-343-3122.  
**Note:** Sit at the control computer while talking with the service technician to ensure efficient service.



## Section 8: Parts Replacement

### 8.1 Parts Replacement List

The following table shows some of the display parts that may eventually need replacement. For unlisted replacement parts, use the label to order a replacement. Most components within a display carry a label that lists the part number of the unit. Refer to **Figure 31** for an example of a typical part label. Note that the part number is in **Bold**.

**0P-1127-0024**  
SN: 2465  
02/19/08 Rev. 1

**Figure 31:** Typical Part Label

**Notes:** Disconnect power when servicing the display. Only qualified service personnel should service internal electronic components.

Part Description	Part Number
Module; AF-3500 46 mm RGB	0A-1541-5550
Module; AF-3500 46 mm Amber	0A-1541-5009
Module; AF-3500 46 mm Red	0A-1541-5008
M3 Controller III	0A-1382-0016
Multi-Line Controller (4053)	0P-1273-0067
Power Supply, 8.5-12.5V (RGB, Amber)	A-2481
Power Supply, 3-6.5V (Red)	A-2307
Transformer	T-1119
Transformer, International	T-1121
RFI Filter	Z-1007
Temperature Sensor	0A-1151-0005
Thermostat	0A-1327-3104
Light Sensor Assembly	0A-1327-3000
Light Sensor Assembly	0A-1327-3013
Light Sensor Cover Assembly	0A-1213-4009
Axial Fan	B-1053
Axial Fan	B-1068
Air Filter	EN-2310
Air Filter, Rigid Pad	EN-2345
Quick Connect; Input, Serial	0P-1415-2000
Primary signal input, RJ45	J-1474
Primary signal output / Mirror signal input	J-1470
Cable; RJ45, CAT5E, Shielded, 2'	W-1537
Cable; RJ45, CAT5E, Shielded, 20'	W-1547
Cable; 22 Awg 2-Pair, Dual Foiled, Single	W-1234
Cable Assy; 20 pos Ribbon, 18", Dual Row	W-1387

Ribbon Assy, 36"	0A-1000-0018
Ribbon Assy, 42"	0A-1000-0019
Ribbon Assy, 60"	0A-1000-0021
Ribbon Assy, 72"	0A-1000-0022
Ribbon Assy, 96"	0A-1000-0024
Ribbon Assy, 108"	0A-1000-0025
Ribbon Assy, 24"	0A-1000-0074
Interconnect Cable; RJ45	W-1921
CAT5e; 30', RJ45	W-1999
Electrical Contact Cleaner/Lubricant	CH-1020
Hex Wrench, T-Handle 1/8" RT for modules	TH-1062
Wireless Bridge Communications Enclosure	0A-1327-1100
Wired Ethernet Communications Enclosure	0A-1327-1101
Fiber Ethernet Communications Enclosure	0A-1327-1102
Wi-Fi Communications Enclosure	0A-1327-1103
Label/Gasket RJ34 Primary Input	0A-1327-1028
Label/Gasket Assy, RJ45, Mirror Input Quick Connect	0A-1327-1029
Label/Gasket Assy, RJ45, Primary Input Quick Connect	0A-1327-1024
Harness, POL, PS(4 PIN) TO MOD, 36"	0A-1327-2150
Harness, POL, PS(4 PIN) TO 2 MOD, 36"	0A-1327-2155
Harness, POL LVD, PS TO 2 MOD, 60"	0A-1327-2105

## 8.2 Instructions for Replacing Parts

### Module Replacement

**Tool required:** 1/8" Hex wrench

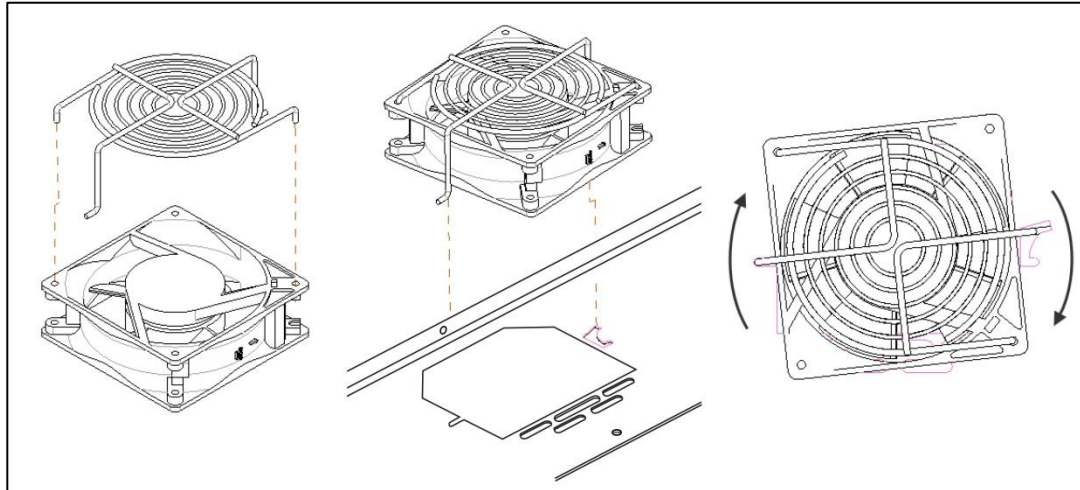
If LEDs fail, do not attempt to replace individual LEDs. Return a failed module to Daktronics for replacement and/or repair.

1. Turn off power to the display.
2. Follow the instructions in **Section 6**: to release the module from the display cabinet.
3. Unplug the power cables by squeezing the tabs on the sides of the plug head and pulling out.
4. Disconnect the two ribbon cables from the module, noting the connection to the back. To release the ribbon cables, spread the tabs on the sides, and then lift the cable head from the jack.
5. Connect all three cables to the new module, and then tightly push the ribbon cable tabs against the cable head. Carefully push the ribbon wires back into the cabinet to clear them from the module edges.
6. Place the module into its proper location.

7. Check that the weather stripping is in place. The weather stripping on the back edge of the module must be in good condition and returned to its proper position in order to prevent water from entering the display.
8. Latch the module tightly both top and bottom by turning the hex wrench a quarter turn clockwise. The module latches must be fully engaged to create a watertight seal around the edge of the module.

## Fan Replacement

Tools required: None



**Figure 32:** Fan Assembly

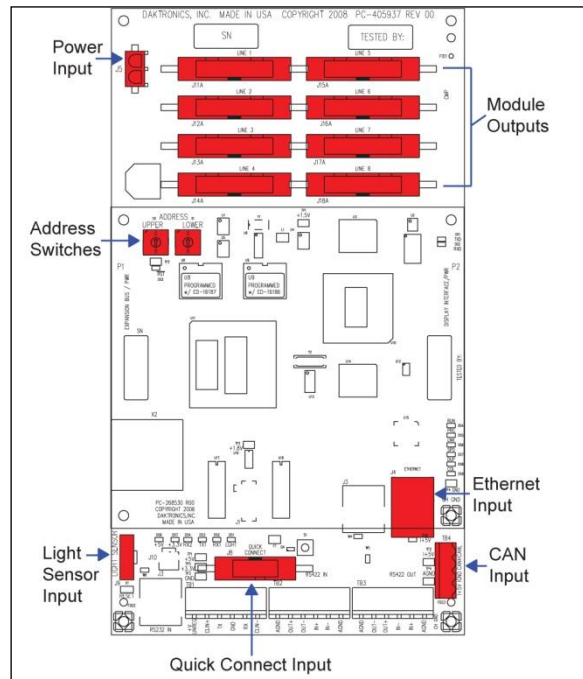
1. Disconnect the fan from the wiring harness by pulling the harness' female plug end from the fan's male prongs.
2. Press the wire extensions on the finger guard, and then rotate the fan assembly counter-clockwise.
3. Remove the fan guard from the fan and set it aside.
4. Remove the fan from the display.
5. Insert the replacement fan into the display. Refer to **Error! Reference source not found.** When installing the replacement fan note the airflow directional arrows. The vertical arrow should be pointing up, indicating airflow in to the display.
6. Place the fan guard on top of the fan and align the finger guard as shown.
7. Place the assembly back on the false bottom surface with the wire extensions into the cutouts. Push the assembly down and rotate it clockwise.
8. Reconnect the fan to the wiring harness by pushing the harness' female plug end onto the fan's exposed prongs.

## Controller Replacement

**Tools required:** 1/8" Hex wrench, 5/16" Nut driver, Flathead screwdriver

To replace a controller in the display:

1. Turn off power to the display.
2. Remove the module directly in front of the controller in the lower left area of the display. Refer to **Figure 22** for the location.
3. Loosen the screws and remove the cover in front of the controller.
4. Disconnect the power input.
5. Remove all power and signal connections from the board. Label the cables as to ensure proper replacement.
6. Remove the six nuts holding the board in place using a 5/16" nut driver.
7. Take note of the rotary address on the controller to ensure the address on the replacement board is the same. Refer to the **Controller Address Setting** section for additional information. Refer to **Figure 33** and **Figure 34**.
8. To install the new controller, replace the six nuts holding it to the display back. Reconnect power and signal cables. Turn on power, observe the start-up sequence, and then note that the pixel in the lower-right corner shows power.



**Figure 33:** Galaxy Controller

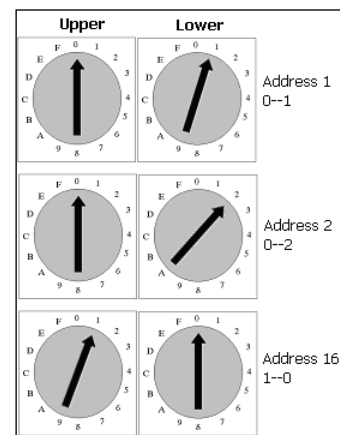
### Controller Address Setting

The rotary switches set the hardware address, which the software uses to identify each particular display. Each controller in a network needs a unique address.

To set the rotary address switches, rotate them until the arrow points to the desired number. To activate test mode or to change an address, turn off power to the display and then turn it back on.

#### Notes:

- Setting both rotary switches to address 0 will activate Test Mode. Turn the display's power off and back on to activate testing.
- After testing, reset the rotary switches to an address other than 0/0 and repower the controller (the software will not recognize an address of 0).



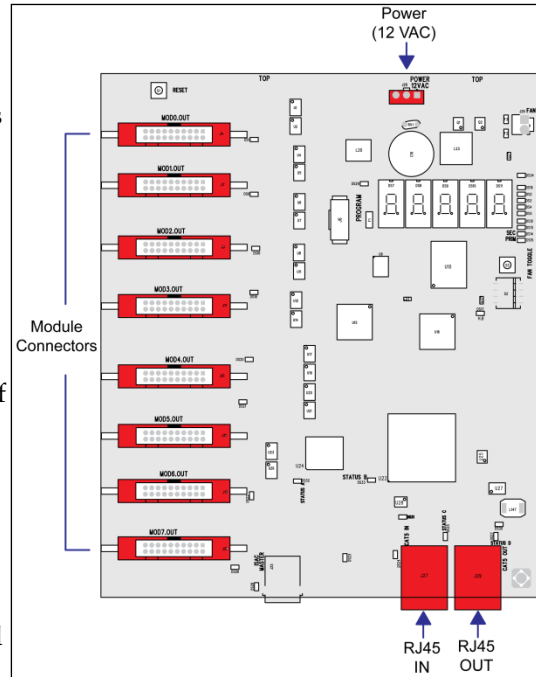
**Figure 34:** Rotary Address Switches

## MLC Replacement

**Tools required:** 1/8" Hex wrench, 5/16" Nut driver, Flathead screwdriver

In mirror displays, the multi-line controller (MLC) receives signal from the primary controller and distributes it to the modules. Ribbon cables run from the module connectors on the MLC to the first modules in each row via ribbon cables. The power supply nearest the MLC will provide its power via a transformer, which receives power from the power termination panel.

1. Turn off power to the display.
2. Remove the module directly in front of the MLC. Refer to **Figure 22** for the approximate location.
3. Disconnect the input cables.
4. When removing all ribbon cables label the module numbers to ensure proper replacement.
5. Remove the six nuts holding the board in place using a 5/16" nut driver.
6. To install the new MLC, move the unit into place and replace the six nuts holding it to the display back.
7. Reconnect input and ribbon cables.
8. Turn on power and observe the start-up sequence. Note that the LEDs to the right of the fiber jacks are on; DS23 to the left of the fiber cable should be off. Refer to **Figure 28** and **Figure 35** for more information.



**Figure 35:** Multi-Line Controller

## Power Supply Replacement

**Tool required:** Phillips screwdriver

Galaxy® 46 mm displays use two different power supplies, depending on the type of module used. Displays with red modules use 135-watt power supplies. Displays with amber or RGB modules use 150-watt power supplies.

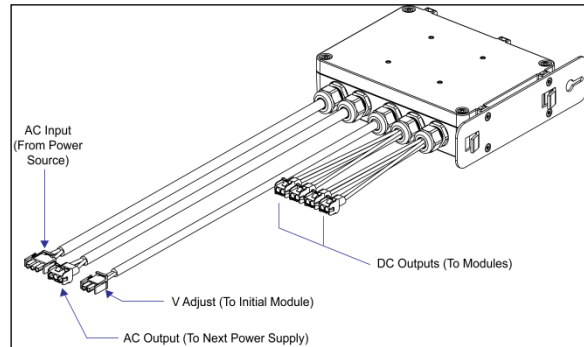
Module Type	Modules per Power Supply	Voltage	Outputs
Red	Eight	6.5	2 pin DC
Amber	Six	11.6	4 pin DC
RGB	Three	9.2	4 pin DC

A Mate-N-Lok® cable connects each module to a wire harness on the power supply. Refer to **Figure 36**.

The V adjust cable connects to a module and is used to calibrate the power supply to the appropriate module voltage. If this cable is not connected, the section of modules will appear dimmer than the rest of the display.

To replace a power supply:

1. Turn off power to the display.
2. Remove the module directly in front of the appropriate power supply.
3. Disconnect the Mate-N-Lok® connectors from the power source as well as those going to the modules. Label each connector to ensure proper reconnection.
4. Loosen the screw holding the power supply bracket to the cabinet upright and lift it off the hooks.
5. Carefully pull the power supply out of the cabinet.
6. Move the new power supply into place and tighten the screw on the support bracket.
7. Reconnect all the Mate-N-Lok® plugs and the V Adjust cable so that each module will receive power.



**Figure 36:** Power Supply

### Light Sensor Replacement

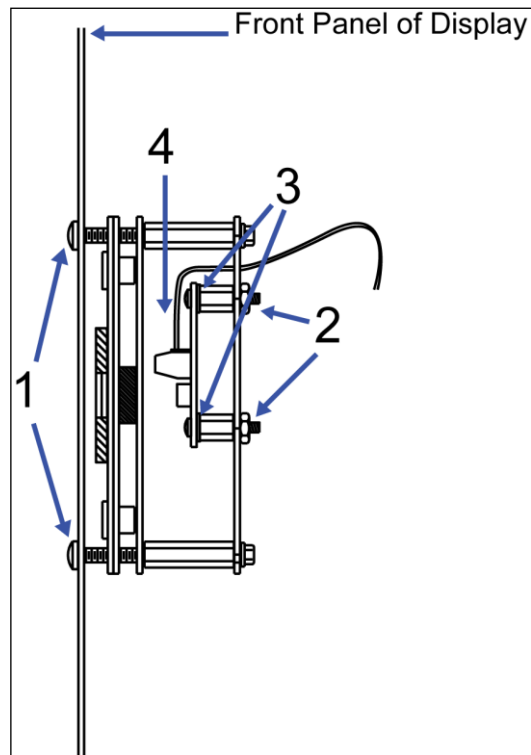
**Tools required:**  $\frac{3}{16}$ " Nut driver, Phillips screwdriver

Locate the light sensor assembly inside the bottom left edge of the cabinet. Refer to **Figure 22**.

If the light sensor fails, replace the circuit board. Remove the bottom left module on the display to access the light sensor.

To replace a light sensor circuit board:

1. Remove the screws that hold the light sensor to the cabinet. Refer to **Figure 37**.
2. Remove the #4-40 nuts securing the circuit board to the plate.
3. Remove the standoffs and attachment screws from the board.
4. Disconnect the four electrical wires on the sensor by unscrewing each screw that holds a wire in place. Note the order of the wires to ensure proper reconnection on the replacement. Do not detach the light sensor plug on the controller.
5. Reattach the new circuit board, following these steps in reverse.



**Figure 37:** Light Sensor Assembly



**Note:** Align the new circuit board so that the lens lines up with the 1/2" circular opening in the bottom left edge of the display when the assembly is in place.

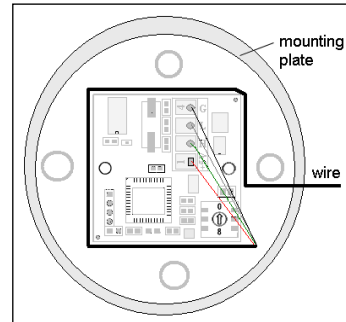
## Temperature Sensor Replacement

**Tools required:** 1/4" Nut driver, Phillips screwdriver

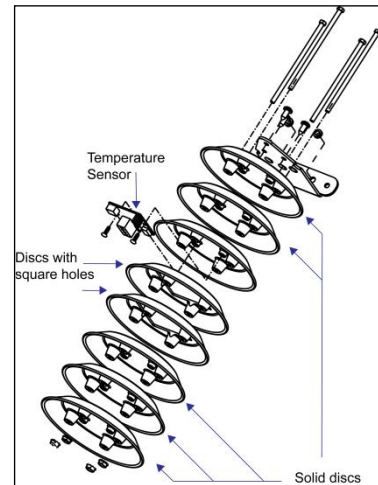
The temperature sensor is a small board inside a plastic housing; typically mounted outside, either near the display or near the building.

To replace a temperature sensor:

1. Remove the four #8-32 nuts from the bottom, and then remove the lower five discs. Three of the discs are solid, while the two in the center have a square hole to fit around the sensor.
2. Label the wires connected to the temperature sensor board, and then disconnect the cable from the temperature sensor terminal block in the sensor housing.
3. Remove the two screws holding the board to the plastic disc.
4. Install the new board, and replace the two screws.
5. Reconnect the cable to the temperature sensor board, and ensure all the wires make a good electrical connection.
6. Route cable around the sensor board as shown in **Figure 38**, and then reassemble the sensor enclosure.



**Figure 38:** Wire around Sensor Board



**Figure 39:** Temperature Sensor (Disassembled)



# Section 9: Daktronics Exchange and Repair & Return Programs

---

## 9.1 Exchange Program

The Daktronics Exchange Program is a quick, economical service for replacing key components in need of repair. If a component fails, Daktronics sends a replacement part to the customer who, in turn, returns the failed component to Daktronics. This not only saves money but also decreases equipment downtime. Customers who follow the program guidelines explained below will receive this service.

### Before Contacting Daktronics

Fill in these numbers before calling Customer Service:

Display Model Number: \_\_\_\_\_

Date Installed: \_\_\_\_\_

Location of Display: \_\_\_\_\_

Daktronics Customer ID Number: \_\_\_\_\_

To participate in the Exchange Program:

1. **Call Daktronics Customer Service:** 866-343-3122 to order the exchange part.
2. **When the new exchange part is received, mail the old part to Daktronics.** If the replacement part fixes the problem, send in the failed part within 3 weeks of the ship date.
  - a. Package the old part in the same shipping materials in which the replacement part arrived.
  - b. Fill out and attach the enclosed UPS shipping document.
  - c. Ship the part to Daktronics.

**A charge will be made for the replacement part immediately, unless a qualifying service agreement is in place.**

In most circumstances, the replacement part will be invoiced at the time it is shipped. If the failed part or replacement part is not returned to Daktronics within 3 weeks of the ship date, Daktronics will assume that the customer is purchasing the replacement part and will send an invoice for the value of the new sale part. If the part or parts are returned within 2 weeks of the second invoice date, Daktronics will credit the customer for the second invoice. If after 2 weeks Daktronics has still not received the parts back, the customer must pay the second invoice and will not be credited for the return of the failed part. Daktronics reserves the right to refuse parts that have been damaged due to acts of nature or causes other than normal wear and tear.

## 9.2 Repair & Return Program

For items not subject to exchange, Daktronics offers a Repair & Return Program. To send a part for repair, follow these steps:

1. **Call or fax Daktronics Customer Service:**  
Phone: 866-343-3122                      Fax: 605-697-4444
2. **Receive a Return Materials Authorization (RMA) number before shipping.**  
This expedites repair of the part.
3. **Package and pad the item carefully to prevent damage during shipment.**  
Electronic components, such as printed circuit boards, should be placed in an antistatic bag before boxing. Daktronics does not recommend using packing peanuts when shipping.
4. **Enclose:**  
Your name  
Address  
Phone number  
The RMA number  
A clear description of symptoms

### Shipping Address

Daktronics, Inc.  
Customer Service Receiving  
PO Box 5128  
201 Daktronics Drive  
Brookings, SD 57006  
Attn: RMA# \_\_\_\_\_

## 9.3 Daktronics Warranty and Limitation of Liability

The Daktronics Warranty and Limitation of Liability is located in **Appendix E**. The Warranty is independent of Extended Service agreements and is the authority in matters of service, repair, and display operation.

# Glossary

---

**Cabinet:** The metal frame of the display (back, sides, top, and bottom).

**Column:** A vertical line of pixels.

**Controller:** The “brains” of the display. The controller receives signal communication from the computer and sends the information to the modules. Messages and schedules may also be stored on the controller for use when desired.

**Display Address:** An identification number assigned to each display of a network. The control software uses the address to locate and communicate with each display. Displays that are on the same network must have different addresses.

**Galaxy®:** One of Daktronics trademarked names for commercial LED matrix displays.

**Light Emitting Diode (LED):** A low energy, high intensity lighting element. When grouped together, LEDs produce the messages that appear on the display.

**Louver:** Black plastic ledge positioned horizontally above each pixel row. The louvers block sunlight to increase the level of contrast on the display face.

**Mirror:** The second display in a two-sided (2V) configuration. The mirror display does not have a controller, but rather an MLC. It displays an exact copy of the information on the primary display. All signal information to the mirror is received through an inter-connect cable from the primary display.

**Multi-Line Controller (MLC):** Used in mirror displays to repeat data from the primary display and to control the mirror display’s ventilation fans.

**Module:** Modules are the “building blocks” of the display. Individual module sizes vary depending on the pixel pitch of the display. 46 mm Galaxy® modules have a pixel pitch of 8 x 8. Each module is individually removable from the front of the display.

**Network:** Consists of multiple displays connected to each other. As many as 240 primary displays can exist on one network.

**Picture Element (Pixel):** A single LED or cluster of LEDs. The number and color of the LEDs will depend on display application. For example, 46 mm RGB pixels contain three LEDs while 46 mm RED and AMBER pixels contain one LED.

**Pixel Pitch:** The amount of space between the centers of two pixels. The pixel pitch is equidistant both vertically and horizontally.

**Primary:** The first display in a two-sided (2V) configuration. The communication signal, light sensor, and temperature sensor connect to this display. Information is relayed from the primary through an inter-connect cable to the MLC in the mirror so that it shows exactly the same information.

**Venus 1500:** Software used to create messages and send them to displays. The Venus 1500 software manual is included on the software’s installation disk.



## **Appendix A: Reference Drawings**

---

Shop drawings show display dimensions, signal and power connection locations, as well as information on service access and power requirements. To obtain copies of shop drawings or other reference drawings specific to your display, contact Daktronics Customer Service:

**Phone:** 866-343-3122 **Fax:** 605-697-4444





## **Appendix B: Temperature Sensor Installation**

---

The Daktronics manual number is located on the front of the manual, or in the lower left corner of the sheets.

Temperature Sensor Mounting for AF-3700 and AF-3500 Displays .....**ED-16704**



## Appendix C: International Installation

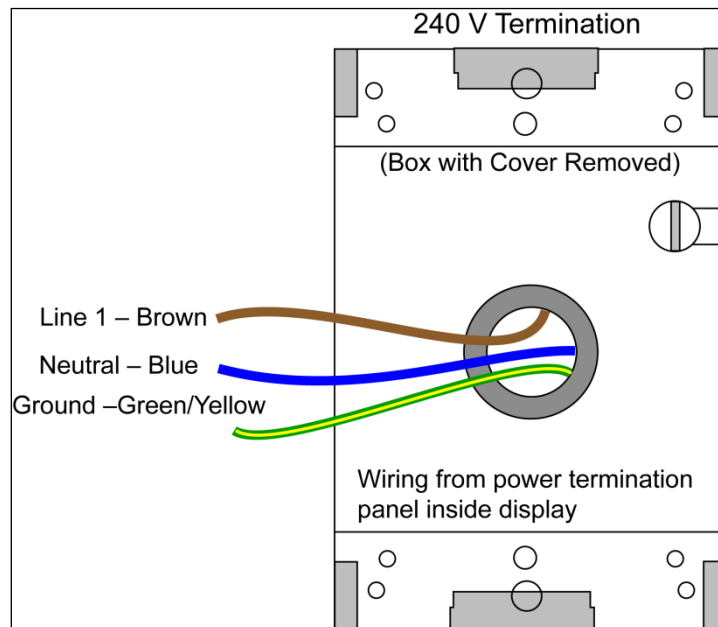
### Terminating Hot, Neutral, and Ground Wires at the J box

1. Route the power cable through conduit to the rear of the display and into the power termination J box.
2. The power termination enclosure will contain two wires plus a ground coming from the interior of the display. These wires are pre-terminated to the power termination panel inside the display.

**Note:** The following colors are used for the pre-terminated wires:

240 VAC	
Line 1	Brown
Neutral	Blue
Ground	Green/Yellow

3. Inside the display's external power termination J box, connect the power wires to the wires coming from the display interior using wire nuts. Refer to **Figure 40**.



**Figure 40:** 240 V Power Termination

### Terminating Single-Phase Power to the Internal Power Termination Panel

Daktronics displays used for international applications are equipped with different power termination panels than domestic displays. However, the termination method is similar to the domestic termination discussed in **Section 3.5**.

1. Open the display as explained in **Section 6**: and locate the power termination panel.

2. Route the cable through conduit to the back of the display. Use the  $\frac{3}{4}$ " knockout for access, careful not to damage internal components.
3. Remove the cover of the power termination panel.
4. Connect the neutral wire to the neutral lug and the live wire to the Line 1 lug. The ground wire connects to the grounding bus bar.

## Appendix D: Maintenance Log

---

Inspection Item	Date performed								
General: Exterior Visual Inspection									
General: Interior Visual Inspection									
Modules: Weather Stripping									
Modules: Electrical Connections									
Modules: Latch Operation									
Ventilation System: Fans									
Ventilation System: Filters									
Hardware/Fasteners: Loose bolts, nuts, screws, rivets, etc.									
Cabinet (Int. & Ext.): Paint cracking and peeling									
Cabinet (Int. & Ext.): Metal Corrosion									



# Appendix E: Daktronics Warranty and Limitation of Liability

---

The Daktronics manual number is located on the front of the manual, or in the lower-left corner of the sheets.

Daktronics Warranty and Limitation of Liability .....**SL-02374**