

DISPLAY INFO			
NPN 6400-1.2MD - 2160X360			
QUANTITY: 1			
PIXELS PER PANEL: 1.2 - 270 X 480			
PANEL WEIGHT: 16.9 LBS EACH (7.67 KG)			
BORDERS: STANDARD BORDERS - PANEL LENGTHS			
CUSTOM FEATURES:			
SPEED FRAME HARDWARE PER DISPLAY TASK			
DESCRIPTION	PART #	QUANTITY	PART VIEW
SPEED FRAME ASSY, 2X2, NPN D1	0A-2292-2022	1	N.A.
SPEED FRAME ASSY, 2X3, NPN D1	0A-2292-2023	2	N.A.
SPEED FRAME ASSY, 3X2, NPN D1	0A-2292-2032	2	N.A.
SPEED FRAME ASSY, 3X3, NPN D1	0A-2292-2033	4	N.A.
BOLT, 7/32 X 0.875", HEX SEERR FL (SPEED FRAME STITCH BOLTS)	HC-1842	36	
TEK SCREW, 7/16 X 3" (STEEL STUD ATTACH)	HC-3979953	68	
SPAX POWERLAG SCREW, 7/8 X 9" (WOOD STUD ATTACH)	HC-5100765	68	
7/11 HOLLOW BOLT, 0.344" HOLE, 1" LONG	HC-5098762	68	
WOOD LAG SCREW, 5/8 X 4"	HC-5100786	68	
Z-ADJUST BRACE PLATE, NPN D1 SPEED FRAME	0M-4951150	68	
SEISMIC CLIP, NPN D1 SPEED FRAME	0M-4983082	68	
TAP SCR, #10-16 X 0.375, PHIL, HEX WSHR HEAD	HC-1186	72	
BOLT, M6-1.0 X 16MM (SPEED FRAME HEAD, 5MM HEX (PANEL TO SPEED FRAME))	HC-4884317	268	
CAP SCREW, M6-1.0 X 20MM SOCKET (JACKING BOLT)	HC-1795	504	

NPN WEIGHT TABLE			
DESCRIPTION	WEIGHT (EA) LBS	QTY	WEIGHT (TOTAL) LBS
NPN 1.2MN PANEL	16.9	64	1081.6
STRUCTURE - 3X3 SPEED FRAME	23.0	4	92.0
STRUCTURE - 3X3 SPEED FRAME	21.5	2	43.0
STRUCTURE - 2X3 SPEED FRAME	21.5	2	43.0
STRUCTURE - 2X2 SPEED FRAME	14.5	1	14.5
HARDWARE	50	1	50.0
SUB TOTAL			1324
+10% MARGIN			1457

WEIGHT TABLE DOES NOT INCLUDE ANY MAIN POWER OR SIGNAL WIRING THAT MAY CONTRIBUTE TO ADDITIONAL WEIGHT ON THE WALL

FRAME FASTENER REFERENCE TABLE				
WALL SUBSTRATE	FASTENER DAK PART NUMBER	FASTENER DESCRIPTION	HOLLOW BOLT DAK PART NUMBER	HOLLOW BOLT DESCRIPTION
STEEL STUD	HC-3979953	7/16 X 3" TEK 3 SELF-DRILLING SCREW	HC-5098762 (SHIPS ATTACHED)	5/8-11 HOLLOW BOLT, 0.281" HOLE, 1.000" LONG
WOOD STUD	HC-5100765	7/8 X 9" SPAX POWERLAG SCREW	HC-5098762 (SHIPS ATTACHED)	5/8-11 HOLLOW BOLT, 0.281" HOLE, 1.000" LONG
PLYWOOD (CUSTOM) REQUIRES NON-STANDARD HOLLOW BOLT	HC-5100786	5/8 X 4" WOOD LAG SCREW	HC-5098762 (SHIPS SEPARATE)	5/8-11 HOLLOW BOLT, 0.344" HOLE, 1.000" LONG

FRAMES TO BE INSTALLED DIRECT TO STUDS OR PLYWOOD. INSTALL HC-3979953 TEK SCREWS PER ITW BUILD EX & CO'S ESR-1976. INSTALL HC-5100765 SPAX POWERLAG SCREWS PER SPAX & TER 1912-07. NOTE: STEEL STUD ATTACHMENT SHOWN IN DRAWING.



STANDARD NPN VIEWS AND NOTES: MAX PANEL WEIGHT (MODS, HDWR, CABLES, INCLUDED): 16.9 LBS (7.67 KG)

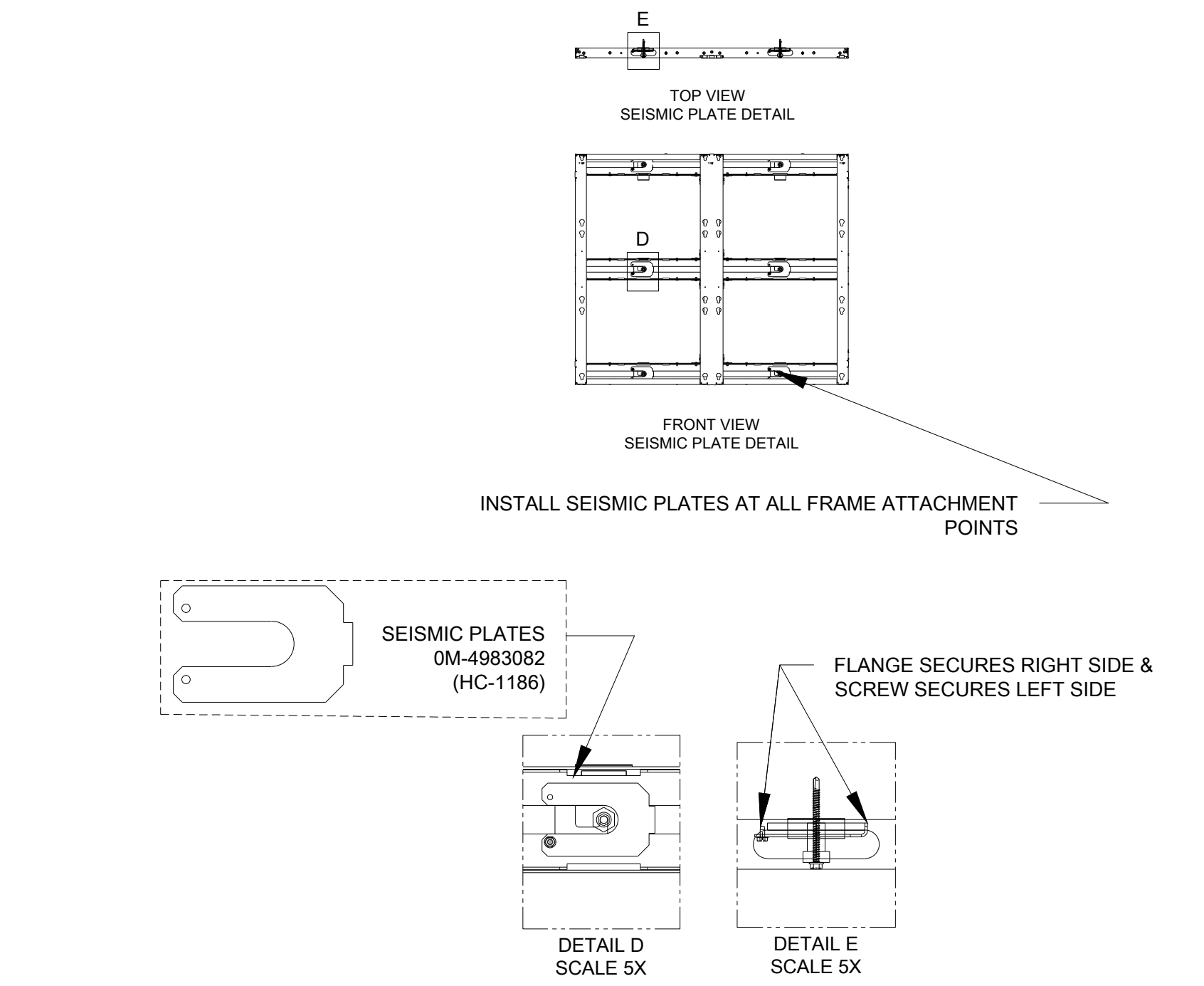
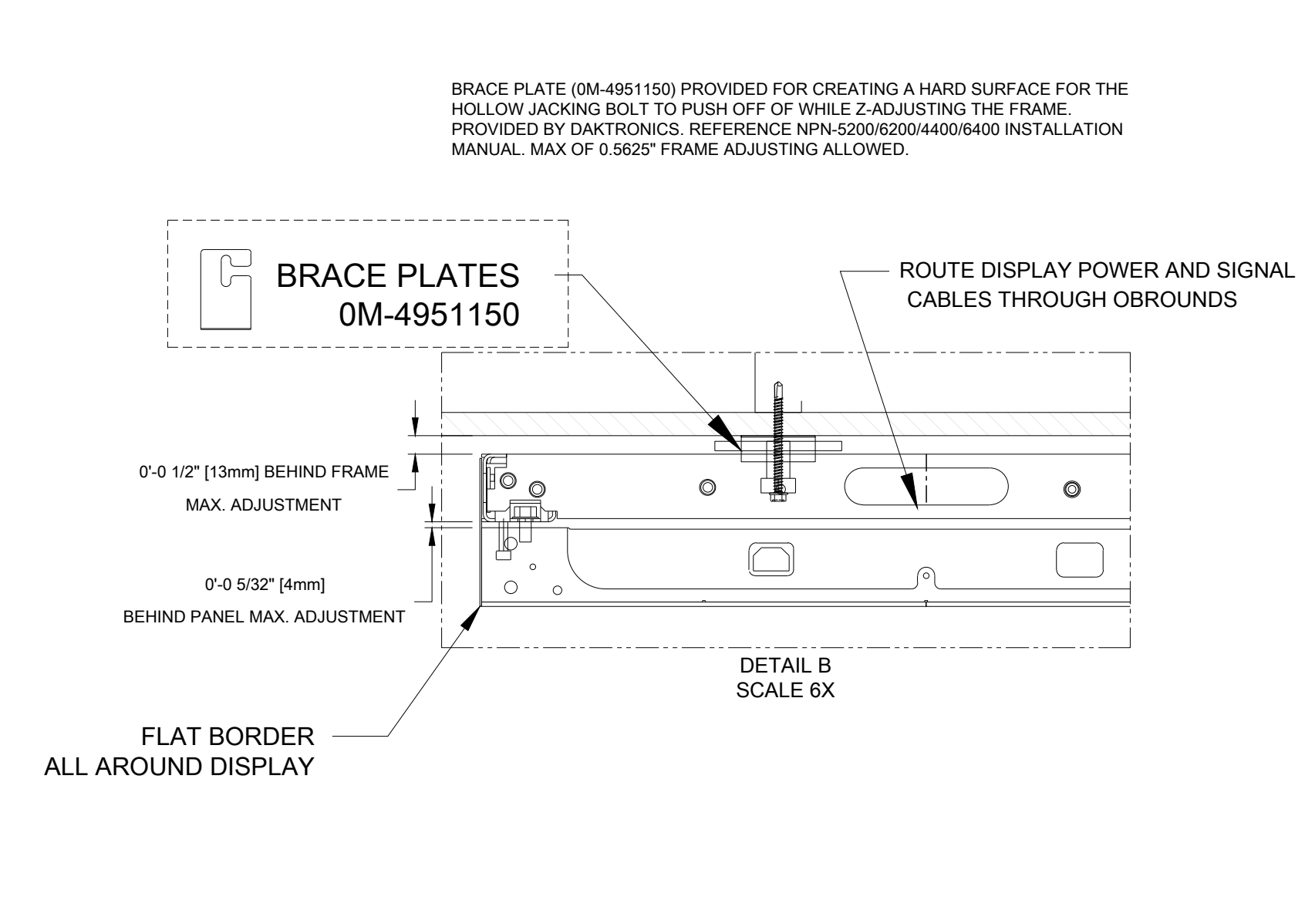
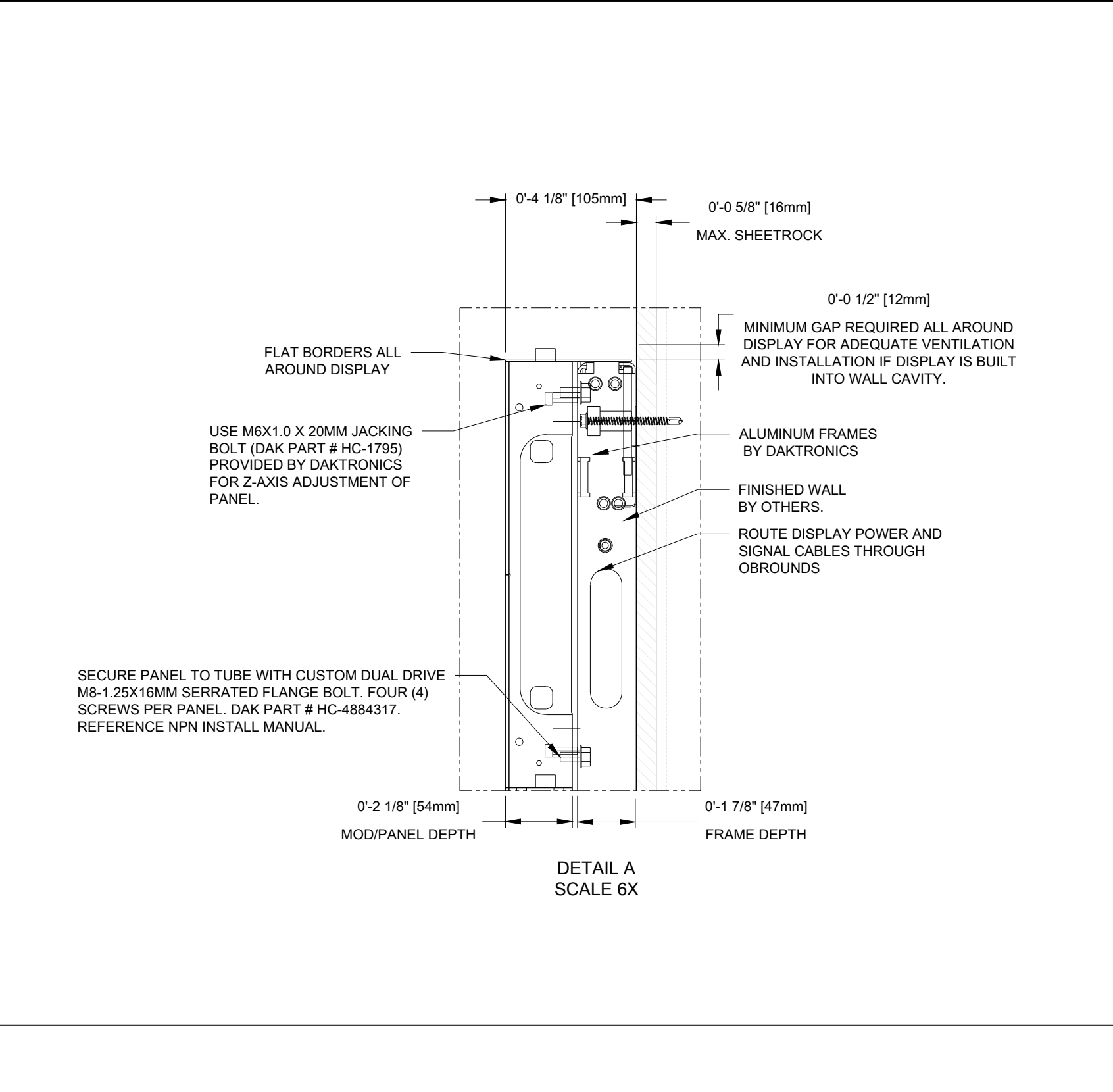
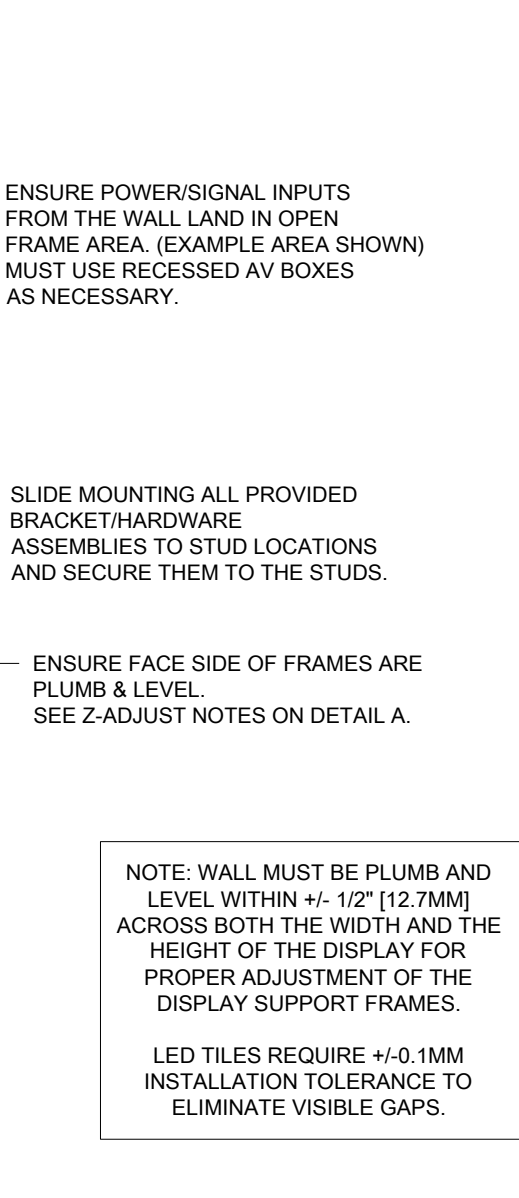
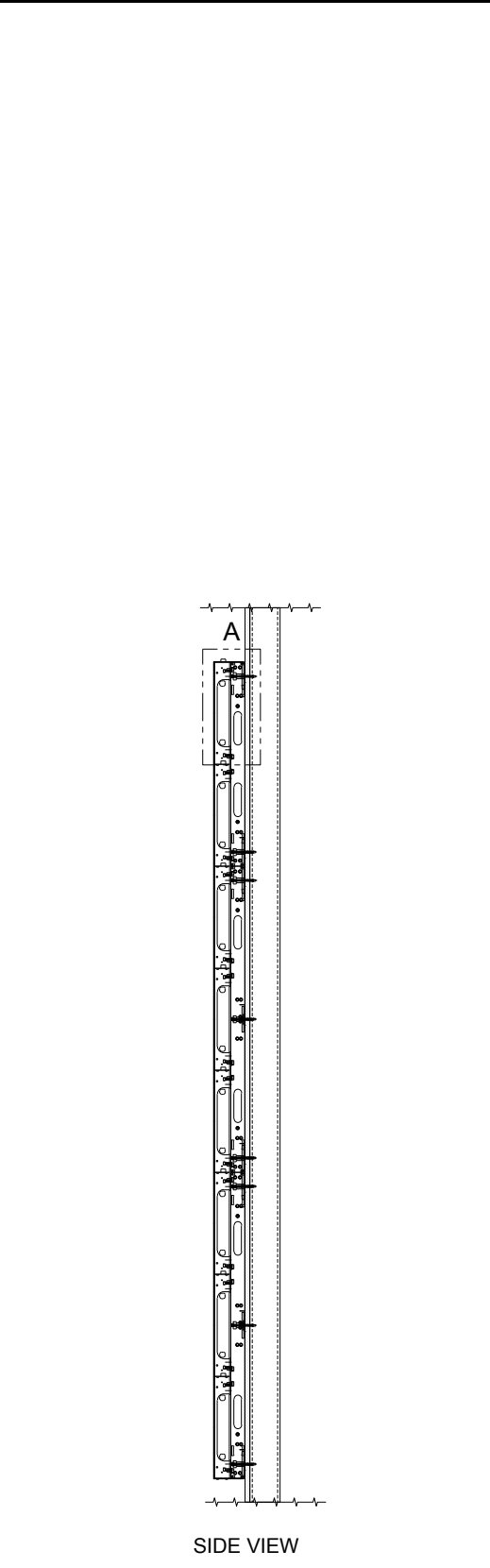
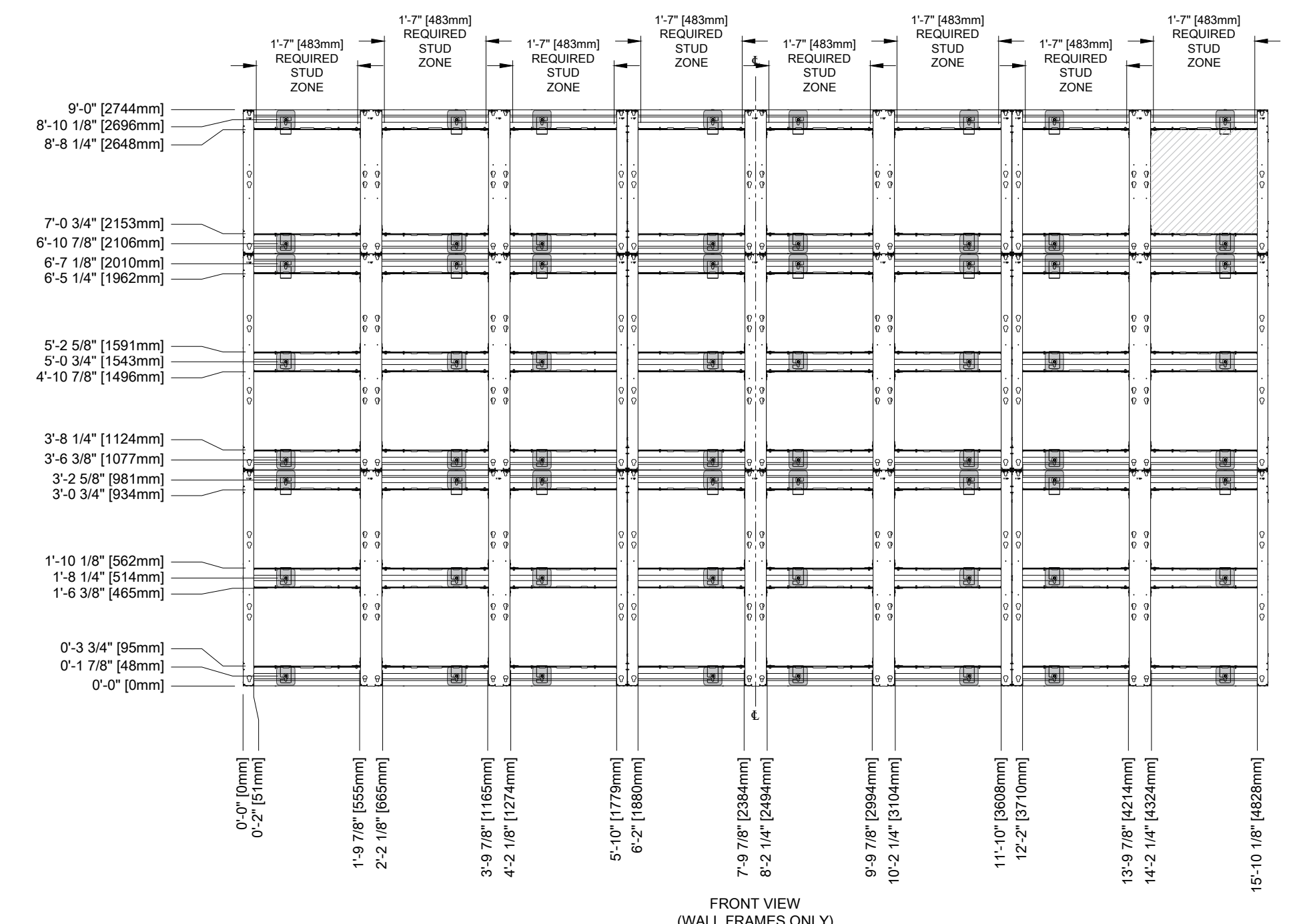
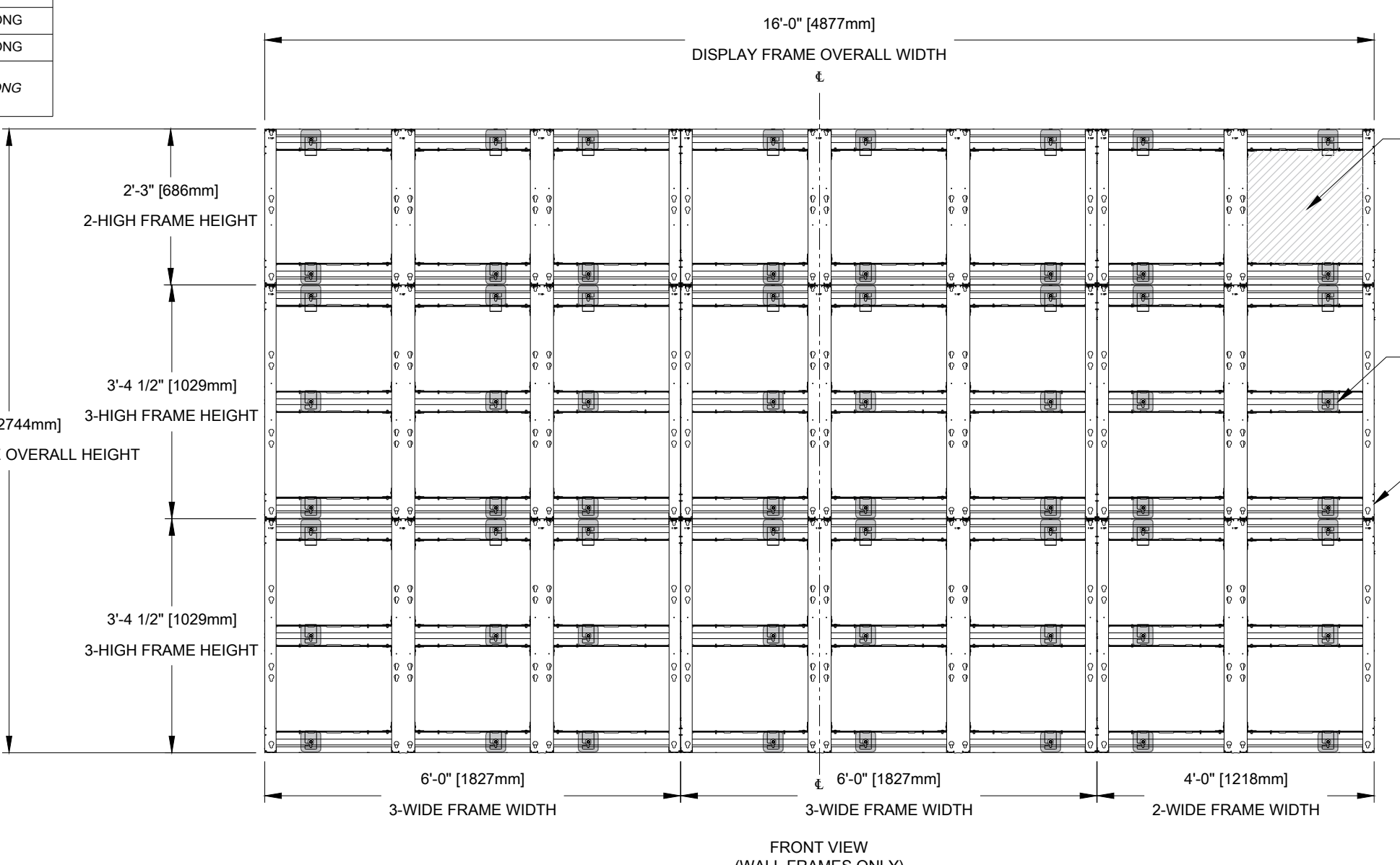
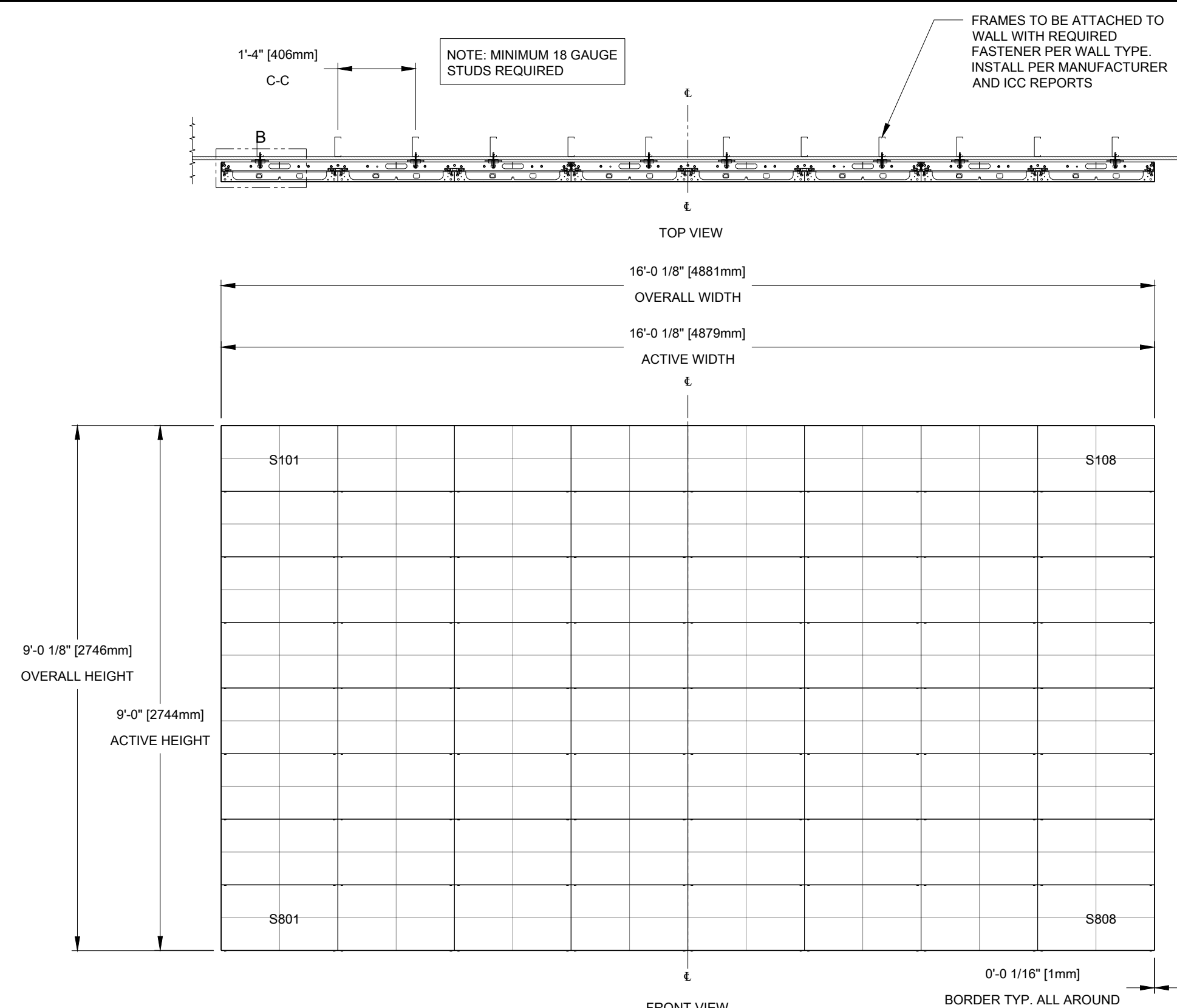
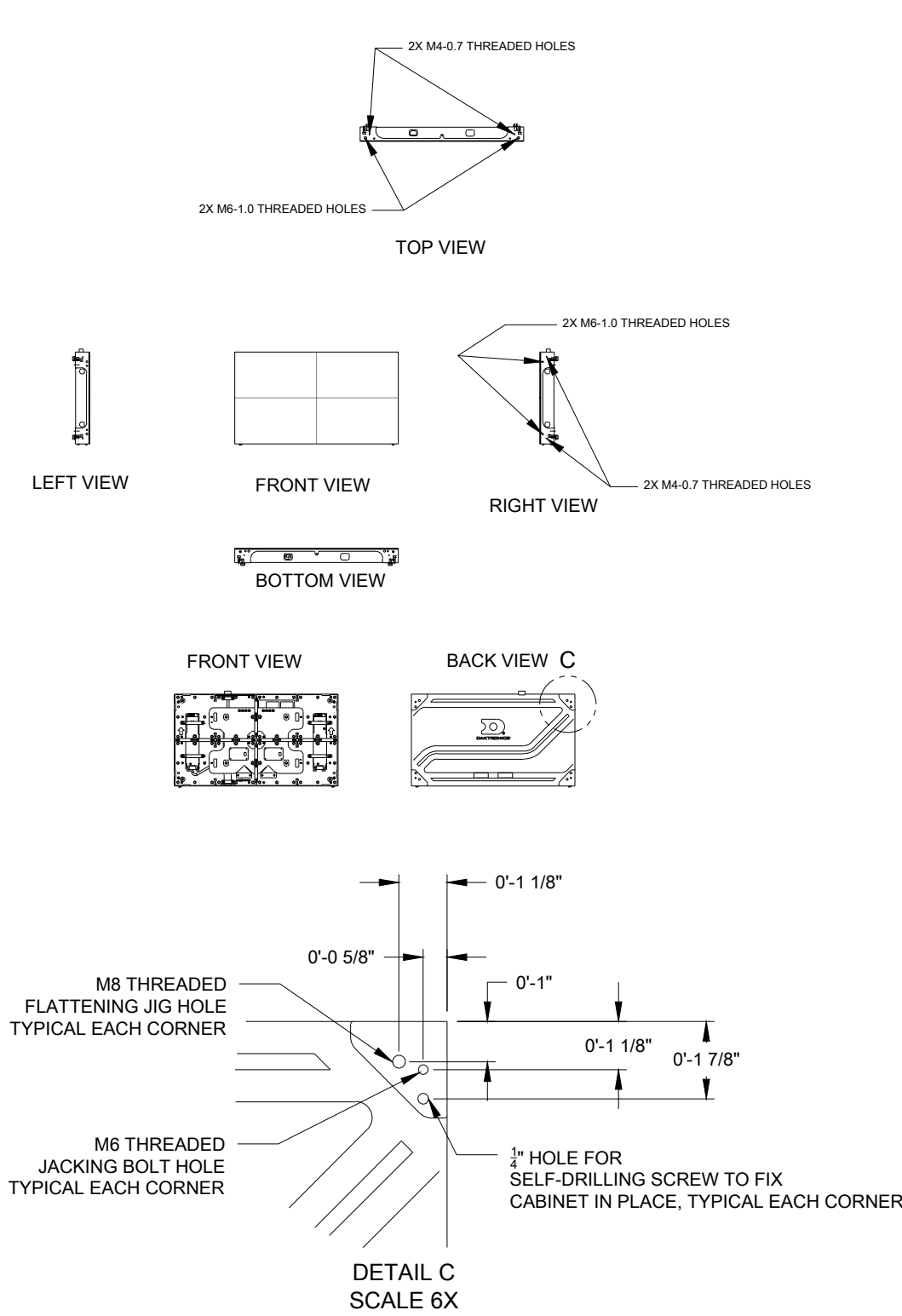

SUBMITTAL APPROVAL

APPROVED  APPROVED AS NOTED  APPROVED AS NOTED & RESUBMIT

COMPANY: \_\_\_\_\_

SIGNED: \_\_\_\_\_

TITLE: \_\_\_\_\_ DATE: \_\_\_\_\_

PENDING APPROVAL  
NOT FOR CONSTRUCTION



SCAN QR CODE OR CLICK HERE FOR: NPN-X200/X400 SERIES INSTALLATION DOCUMENTS DD0014611

- NOTES:
- REFERENCE
    - REFER TO DAKTRONICS PROPOSAL DRAWING FOR DISPLAY COMPONENT SPECIFICATIONS.
    - REFER TO DAKTRONICS SYSTEM RISER DIAGRAM FOR POWER AND SIGNAL SPECIFICATIONS.
    - REFER TO NPN DISPLAY MANUAL DD3918319 FOR DISPLAY INSTALLATION DETAILS.
  - GENERAL NOTES
    - ALL DIMENSIONS ARE IN FEET AND INCHES. DIMENSIONS ARE APPROXIMATE AND SUBJECT TO CHANGE DUE TO DETAILED DESIGN CONSIDERATIONS.
    - IT WILL BE THE UNDERSTANDING OF DAKTRONICS THAT SHOP APPROVAL IMPLIES THAT A QUALIFIED ENGINEER HAS REVIEWED THE ADDITION OF THE DISPLAY LOADS TO THE BUILDING AND THAT THE BUILDING STRUCTURE HAS BEEN DEEMED ACCEPTABLE TO SUPPORT THE ADDITIONAL LOADS AS DETAILED.
    - PAINT PLAN:
      - DISPLAY CABINETS: SEMI-GLOSS BLACK
      - VISIBLE STRUCTURE: SEMI-GLOSS BLACK
    - REFER TO INSTALLATION AND MAINTENANCE MANUAL FOR COMPLETE INSTALLATION INSTRUCTIONS.
  - DISPLAY NOTES
    - DAKTRONICS DISPLAYS ARE FRONT SERVICE.
  - STRUCTURAL NOTES
    - WEIGHT ALLOWANCE INCLUDES ALL EQUIPMENT AND ACCESSORIES NECESSARY FOR SAFELY MOUNTING THE EQUIPMENT TO THE DISPLAY STRUCTURE.
    - SUPPORT STRUCTURE IS ALUMINUM CONSTRUCTION.
    - CODE: STRUCTURAL DESIGN IS BASED ON THE INTERNATIONAL BUILDING CODE, 2009 EDITION.
    - LATERAL LOAD: 5 PSF HORIZONTAL PRESSURE APPLIED TO SURFACES NOT EXPOSED TO OUTDOOR WIND PRESSURE. DISSIMILAR METALS IN CONTACT SHALL BE INSULATED WITH PAINT OR OTHER APPROVED COATING TO PREVENT GALVANIC CORROSION.
  - PROJECT RESPONSIBILITIES
    - ALL ON-SITE WORK TO BE DONE IN ACCORDANCE WITH OSHA AND ALL LOCAL CODES THAT APPLY.
    - DAKTRONICS SUBCONTRACTORS RESPONSIBLE FOR JOBSITE SAFETY.
    - DAKTRONICS SUBCONTRACTORS ARE SOLELY RESPONSIBLE FOR THE DESIGN AND INSTALLATION OF ALL TEMPORARY BRACING AND OTHER ELEMENTS AND EQUIPMENT NECESSARY FOR A SAFE INSTALLATION.
    - EACH SUBCONTRACTOR IS RESPONSIBLE FOR THE REMOVAL AND DISPOSAL OF WASTE MATERIALS ON THE JOBSITE.
    - DAKTRONICS AND OWNERS SUBCONTRACTORS SHALL VERIFY ALL EXISTING DIMENSIONS AND CONDITIONS PRIOR TO INSTALLATION.
    - REFER TO STANDARD FORM AGREEMENT BETWEEN CONTRACTOR AND SUBCONTRACTOR (AA-4401) AND ATTACHED DOCUMENTS FOR DETAILED SCOPE OF WORK AND RESPONSIBILITY.