

**Galaxy<sup>®</sup> Outdoor  
Series AF-3190**

**Display Manual**

**ED13744**

**Rev 3**

**23 January 2005**

**DAKTRONICS**

**ED13744**  
**Product 1259**  
**Rev 3 – 23 January 2005**

## **DAKTRONICS, INC.**

### **Copyright © 2005**

All rights reserved. While every precaution has been taken in the preparation of this manual, the publisher assumes no responsibility for errors or omissions. No part of this book covered by the copyrights hereon may be reproduced or copied in any form or by any means – graphic, electronic, or mechanical, including photocopying, taping, or information storage and retrieval systems – without written permission of the publisher.

*Galaxy® is a registered trademarks of Daktronics, Inc. All others are trademarks of their respective companies.*

# Table of Contents

---

<b>Section 1:</b>	<b>Introduction.....</b>	<b>1-1</b>
1.1	Safety Precautions .....	1-2
1.2	Network Concepts .....	1-2
	RS232 Network .....	1-3
	RS422 Network .....	1-3
	Modem Network.....	1-3
	Fiber Optic Network.....	1-3
	Radio Network.....	1-3
	Ethernet Network.....	1-3
1.3	Display Overview .....	1-4
1.4	Component Identification .....	1-5
1.5	Daktronics Nomenclature .....	1-7
<b>Section 2:</b>	<b>Mechanical Installation .....</b>	<b>2-1</b>
2.1	Mechanical Installation Overview .....	2-1
2.2	Support Structure Design.....	2-1
2.3	Ventilation Requirements .....	2-2
2.4	Lifting the Display.....	2-2
2.5	Display Mounting .....	2-3
2.6	Optional Temperature Sensor .....	2-4
<b>Section 3:</b>	<b>Electrical Installation.....</b>	<b>3-1</b>
3.1	Common Connectors in the Display.....	3-1
3.2	Control Cable Requirements.....	3-3
	RS232 .....	3-3
	RS422 .....	3-3
	Modem.....	3-3
	Fiber Optic.....	3-3
	Radio .....	3-3
	Ethernet .....	3-4
3.3	RJ Connector Cables .....	3-4
3.4	Conduit .....	3-5
3.5	Preparing for Power/Signal Connection .....	3-5
3.6	Power.....	3-6
	Grounding.....	3-6
	Power Installation .....	3-7
	Main Disconnect.....	3-7
3.7	Signal Termination from Computer to Sign .....	3-8
	RS232 .....	3-8
	RS422 .....	3-9
	Modem.....	3-11
	Fiber Optic.....	3-12
	Venus <sup>®</sup> 1500 Radio Client.....	3-13
	Ethernet (Wire).....	3-15
	Ethernet (Fiber).....	3-16
	RS422 Interconnection .....	3-17
	Fiber Interconnection.....	3-18
3.8	Optional Temperature Sensor .....	3-18
3.9	First Time Operation .....	3-18

<b>Section 4:</b>	<b>Maintenance and Troubleshooting .....</b>	<b>4-1</b>
4.1	Maintenance and Troubleshooting Overview .....	4-1
4.2	Recommended Tools List .....	4-1
4.3	Signal Summary.....	4-2
4.4	Power Summary.....	4-2
4.5	Display Access.....	4-3
4.6	Service and Diagnostics.....	4-3
	Line Filter .....	4-4
	Modules, Pixel Strips and Drivers .....	4-4
	Controller.....	4-6
	Modem.....	4-8
	Fiber Optic Board .....	4-10
	RS422 Surge Board Assembly .....	4-11
	Ethernet Surge Card.....	4-11
	Media Converter .....	4-12
	Location of CAN termination jumper.....	4-12
	Power Supplies .....	4-13
4.7	Ventilation Systems .....	4-14
4.8	Thermostats .....	4-14
4.9	Sign Maintenance .....	4-14
4.10	Weather Stripping.....	4-15
4.11	Troubleshooting.....	4-15
4.12	Initial Operation Information.....	4-16
4.13	Replacement Parts List .....	4-16
4.14	Daktronics Exchange and Repair and Return Programs .....	4-18
<b>Appendix A:</b>	<b>Reference Drawings .....</b>	<b>A-1</b>
<b>Appendix B:</b>	<b>Signal Converter .....</b>	<b>B-1</b>
<b>Appendix C:</b>	<b>Optional Temperature Sensor .....</b>	<b>C-1</b>

# List of Figures

---

Figure 1: Drawing Label.....	1-1
Figure 2: Version 3 Controller .....	1-5
Figure 3: 8x8 Pixel Module (Front and Rear) .....	1-6
Figure 4: RS422 Signal Converter .....	1-7
Figure 5: Module Numbering Example – 24x80 Front.....	1-7
Figure 6: Module Numbering .....	1-7
Figure 7: Typical Label .....	1-8
Figure 8: Lifting the Display (left; correct) and (right; incorrect) .....	2-2
Figure 9: Ribbon Cable Connector.....	3-1
Figure 10: Termination Block.....	3-1
Figure 11: Phoenix Connector .....	3-1
Figure 12: Mate-n-Loc Connector.....	3-2
Figure 13: Fiber Optic Cable .....	3-2
Figure 14: RJ45 Connector .....	3-2
Figure 15: RS232/6-pin Quick Connect Jack.....	3-2
Figure 16: 8-Conductor RJ45 Connector and Cable .....	3-4
Figure 17: Flipped Cable with RJ Connectors.....	3-4
Figure 18: Opening the Display.....	3-5
Figure 19: Display Grounding .....	3-6
Figure 20: Signal Termination Locations.....	3-8
Figure 21: RS232 Display Layout.....	3-9
Figure 22: J-box to RS232 Input on the Controller Board.....	3-9
Figure 23: RS422 Display Layout.....	3-10
Figure 24: Signal Converter to Surge Board in Display .....	3-10
Figure 25: Modem Display Layout .....	3-11
Figure 26: Modem Connection Locations .....	3-12
Figure 27: Fiber Display Layout.....	3-12
Figure 28: Fiber Signal Connections .....	3-13
Figure 29: Radio Display Layout.....	3-14
Figure 30: Client Radio to Display.....	3-14
Figure 31: Ethernet Display Layout.....	3-15
Figure 32: Ethernet Signal Connection.....	3-15

Figure 33: Fiber Ethernet Layout .....	3-16
Figure 34: Fiber Ethernet Signal Connections .....	3-16
Figure 35: Display Interconnect Cable.....	3-17
Figure 36: RS422 Interconnection .....	3-17
Figure 37: AF-3190 Signal Flow Diagram .....	4-2
Figure 38: Opening the Display .....	4-3
Figure 39: Driver Board.....	4-5
Figure 40: Controller .....	4-6
Figure 41: Modem Board .....	4-9
Figure 42: Modem Jumper Location .....	4-9
Figure 43: Fiber Optic Board .....	4-10
Figure 44: RS422 Surge Suppressor .....	4-11
Figure 45: Ethernet Surge Card .....	4-11
Figure 46: Media Converter .....	4-12
Figure 47: Displays with No External Temperature Sensor .....	4-12
Figure 48: Displays with External Temperature Sensor .....	4-12
Figure 49: CAN Temperature Sensor Termination Jumper.....	4-13

# Section 1: Introduction

---

This manual explains the installation, maintenance, and troubleshooting of the 89mm AF-3190 Galaxy® displays. For questions regarding the safety, installation, operation, or service of this system, please refer to the telephone numbers listed on the cover page of this manual.

The manual contains seven sections: Introduction, Mechanical Installation, Electrical Installation, Maintenance and Troubleshooting, Appendix A, Appendix B, and Appendix C.

- **Introduction** covers the basic information needed to make the most of the rest of this manual. Take time to read the entire introduction as it defines terms and explains concepts used throughout the manual.
- **Mechanical Installation** provides general guidance on display mounting.
- **Electrical Installation** gives general guidance on terminating power and signal cable at the display.
- **Maintenance and Troubleshooting** addresses such topics as removing basic sign components, troubleshooting the sign, performing general maintenance and exchanging display components.
- **Appendix A** lists the drawings included within the manual.
- **Appendix B** includes information about the signal converter.
- **Appendix C** includes information about the Optional Temperature Sensor.

Daktronics identifies manuals by an ED number located on the cover page of each manual. For example, Daktronics refers to this manual as **ED13744**.

Daktronics, commonly uses a number of drawing types, along with the information that each provides. This manual might not contain all of these drawings:

- **System Riser Diagrams:** overall system layout from control computer to display, power and phase requirements.
- **Shop Drawings:** fan locations, mounting information, power and signal entrance points and access method (front and rear).
- **Schematics:** power and signal wiring for various components.
- **Display Assembly:** locations of critical internal display components such as power supply assemblies, controller boards, thermostats and light detectors.

**Figure 1** illustrates Daktronics drawing label. The lower-right corner of the drawing contains the drawing number. The manual identifies the drawings by listing the last set of digits and the letter preceding them. In the example below, the manual refers to the drawing as **Drawing B-206146**. Reference drawings are inserted in **Appendix A**.

THE CONCEPTS EXPRESSED AND DETAILS SHOWN ON THIS DRAWING ARE CONFIDENTIAL AND PROPRIETARY. DO NOT REPRODUCE BY ANY MEANS, INCLUDING ELECTRONICALLY WITHOUT THE EXPRESSED WRITTEN CONSENT OF DAKTRONICS, INC. COPYRIGHT 2004 DAKTRONICS, INC.		
DAKTRONICS, INC. BROOKINGS, SD 57006		
PROJ: GALAXY, AF-3200 & AF-3400 SERIES		
TITLE: SCHEM, PRIMARY SIGNAL, INTERNAL, W/OC		
DES. BY: PGILK	DRAWN BY: LKERR	DATE: 11 MAR 04
REVISION	APPR BY:	1229-R03B-206146
00	SCALE: NONE	

**Figure 1:** Drawing Label

This manual shows all references to drawing numbers, appendices, figures, or other manuals in **bold** typeface, as shown below:

“Refer to **Drawing B-206146** in **Appendix A** for the power supply location.”

Additionally, the manual lists drawings referenced in a particular section at the beginning of that section as seen in the following example:

**Reference Drawing:**

Schem; Primary Signal, Internal, w/QC..... **Drawing B-206146**

Daktronics builds displays for long life and that require little maintenance. However, from time to time, certain sign components need replacing. The **Replacement Parts List** in **Section 4.13** provides the names and numbers of components that may need to be replaced during the life of the sign. Most sign components have a white label that lists the part number. The component part number is in the following format:

OP-\_\_\_\_-\_\_\_\_ (circuit board) or OA-\_\_\_\_-\_\_\_\_ (multi-component assembly).

Following the **Replacement Parts List** is the **Exchange and Repair and Return Programs** in **Section 4.14**. Refer to these instructions if any sign component needs replacement or repair.

## 1.1 Safety Precautions



**Important Safeguards:**

1. Read and understand these instructions before installing.
2. Be sure the display and external enclosures are properly grounded with an earth ground electrode at the display.
3. Disconnect power when servicing the display.
4. **Do not** modify the display structure or attach any panels or coverings to the display without the written consent of Daktronics, Inc.

## 1.2 Network Concepts

The concept of using LED displays as cost effective, high impact method of communication is rapidly growing throughout many industries and businesses. The reasons for this growth are many, but the need for additional features and complexity of multiple display installations has emerged. Daktronics display systems have been designed to meet those needs.

The common thread to most client requests is a means of programming and controlling a group of displays from a central control point. Daktronics responded by developing a powerful system of interconnecting and controlling displays. Great care has been taken to design products that will satisfy a wide variety of installations. Some of the design goals of these systems include the following:

- Easy transfer of messages
- The ability to tell a display or group of displays in the network which message should run
- The ability to determine the status of any display on the network
- The ability to control multiple display technologies on the same network



Tools required for mounting the display depend on the location and size of the display. For some installations, it may be possible to use pre-terminated telephone cables for use with the displays.

There are six network systems available: RS232, RS422, modem, fiber, radio, and Ethernet. Up to 240 displays can exist on one network.

### **RS232 Network**

RS232 (EIA/TIA-232-E) is a standard communication interface that employs a single-ended serial transmission scheme that uses a maximum cable length of 7.6 meters (approximately 25 Feet). This interface was designed for computer communication at short distances. The computer used will require an RS232 communication port. Refer to **Section 3** for additional information.

### **RS422 Network**

RS422 (EIA/TIA-422-B) is a standard communication interface that utilizes a differential balanced transmission scheme that uses a typical maximum cable length of 1.2 km (approximately 4000 feet). The main advantage to RS422 over RS232 is the longer cable length that is possible. A signal converter is needed to convert the computer's RS232 to RS422. Refer to **Section 3** for additional information.

### **Modem Network**

The modem is a standard communication interface that utilizes standard phone transmission lines. The phone company assigns each phone line a number that the modem uses to communicate between computer and display. Each modem network needs to have a dedicated phone line assigned to it. Refer to **Section 3** for additional information.

### **Fiber Optic Network**

A fiber optic network is a standard communication method transmitting light (signal) through a glass fiber. Fiber optic cable has a maximum length of 600 meters (approximately 2,000 feet). A signal converter is needed to convert the computer's RS232 signal to fiber optic signal; a minimum of two fibers is required. Refer to **Section 3** for additional information.

### **Radio Network**

The Radio network is a standard communication method that uses radio waves at high frequencies to transmit signal. The Venus 1500 Radio network has a maximum distance of 450 meters (approximately 1,500 feet) outdoor and 150 meters (approximately 500 feet) indoor. A nearly straight line-of-sight path must be maintained between the server radio connected to the computer and the client radio connected to the display. Refer to **Section 3** and the Venus 1500 Radio Manual, **ED13932**, for additional information.

### **Ethernet Network**

**Note:** The use of a quick connect cable interconnect wiring between display controllers will not allow separate control of the second display if the input signal was Ethernet. Only separately wired primary displays are allowed when controlled by an Ethernet signal.

1. The Ethernet network that uses fiber optic cable is a standard communication method transmitting light (signal) through a glass fiber. When used with the media converter the fiber optic cable has a maximum length of 2000 meters (approximately 1.2 miles). One media converter is needed to convert the

Ethernet signal from the hub or switch to fiber optic signal and then a second media converter is located in the display that converts the fiber signal back to Ethernet. A minimum of two fibers is required. Refer to **Section 3** for additional information.

2. The Ethernet network that uses copper cable is a standard communication interface that utilizes a local area network (LAN). Utilizing Cat-5/Cat-5E cable, this transmission scheme has a typical maximum cable length of 100 meters (approximately 330 feet) from an Ethernet hub or switch. The cable will connect to a network hub and then to the Ethernet surge card in the display. Refer to **Section 3** for more information.

## 1.3 Display Overview

### Reference Drawings:

Power Specs, AF-3190, Amber LEDs .....	<b>Drawing A-178168</b>
Power Specs, AF-3190, Red LEDs .....	<b>Drawing A-178240</b>
Component Layout, AF-3190-**x**-89mm .....	<b>Drawing B-181666</b>
Shop Drawings .....	<b>Refer to Appendix A</b>

Daktronics designs and manufactures the AF-3190 Galaxy® display for performance, reliability, easy maintenance, and long life. The pixels have an 89mm center-to-center spacing and LEDs (light emitting diodes). Each sign section has minimum 24-inch character height. A light sensor on the front of the first display is used for automatic dimming of the LEDs based on the ambient light levels. The configuration of pixels depends on the model of sign ordered.

Refer to the **Drawings A-178168, A-178240** and the **Shop Drawings** for the approximate size, weight, and power requirements for your model of display.

The following describes the Galaxy® model numbers: **AF-3190-RRCCC-89-X**

<b>AF-3190</b>	=	Outdoor 89mm Louvered Galaxy Display
<b>RR</b>	=	Number of Rows High (8, 16, 24, 32, 40 and 48 are available)
<b>CCC</b>	=	Number of Columns Long (32, 48, 64, 80, 96, and 112 are available)
<b>89</b>	=	89mm center-to-center pixel spacing
<b>X</b>	=	LED Color (monochrome red or amber are available)

A typical sign system consists of a Windows® based personal computer (PC) running Venus® 1500 software and one or more displays. Venus® 1500 is a software package that runs under Windows® 98, ME™, NT® 4.0, 2000, or XP Home/Professional operating systems on an IBM-compatible computer. Refer to the Venus 1500 controller manual, **ED13530**, for installation and maintenance of the Venus 1500 editing station.

The displays are single-face units, which are single-sided stand-alone displays. The first display is called the primary, and if mounted back-to-back with a second display; the second display is called the echo. If the second display will be mounted at a distance of more than ten feet from the primary, which is common with the 89mm displays, the quick connect interconnect cable cannot be used. Signal between controllers will need to be hardwired.

## 1.4 Component Identification

The following illustrations and definitions depict some of the more commonly accessed Galaxy<sup>®</sup> sign components. Because Daktronics occasionally alters standard design to meet customer needs, the actual display design may vary slightly from the illustrations below.

This is only a brief overview. Refer to **Section 4** for detailed information on maintaining and troubleshooting various sign components.

**Com Port:** The serial connector on the back of the control computer. The COM port controls the sign through either a 9 or a 25 pin serial connector.

**Controller:** The display's controller is the "brains" of the display. The controller receives, translates, and activates the signal information from the control computer to the appropriate pixels on the display accordingly.

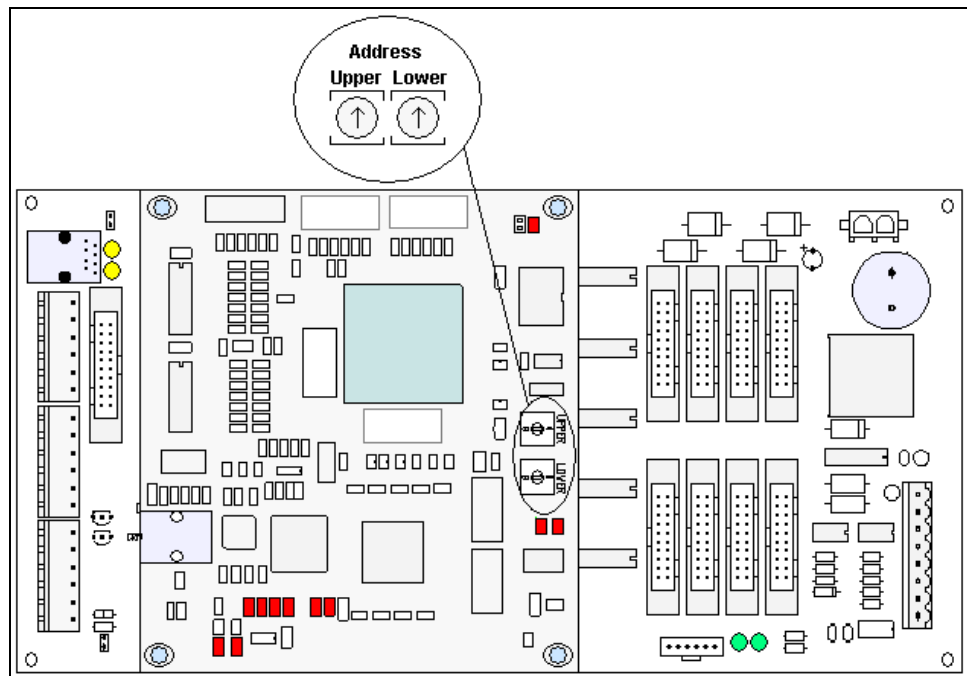

**Figure 2:** Version 3 Controller

**Driver:** The driver is a circuit board responsible for switching the intensity levels of the LEDs. The driver is located inside the driver box and mounts on the back of the module.

**Fiber Optic:** Fiber optic technology uses glass (or plastic) threads (fibers) to transmit data from the controller to the display. A fiber optic cable consists of a bundle of glass threads, each of which transmits messages modulated onto light waves.

**Galaxy<sup>®</sup>:** Daktronics trademarked name for LED monochrome or tri-colored matrix displays.

**Latch Access Fastener:** Device utilizing a rotating retainer bar to hold the module firmly to the sign frame. There is one per module near the center of the module on the right side.

**LED (light emitting diode):** An LED is a low energy, high intensity lighting unit.

**Louver:** Black shade positioned horizontally above each pixel row. The louvers increase the level of contrast on the sign face and direct LED light.

**Module:** 89mm Galaxy<sup>®</sup> modules are 8 pixels high by 8 pixels wide. They consist of pixel strips, louvers, and a driver. Refer to **Figure 3** for identification of these parts.

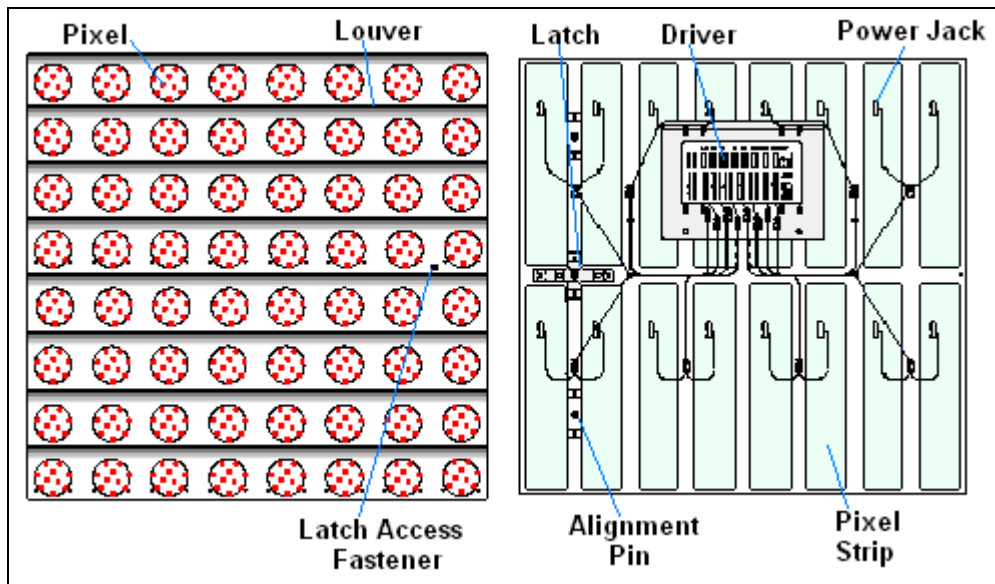

**Figure 3:** 8x8 Pixel Module (Front and Rear)

**Network:** Consists of multiple signs connected to each other.

**Pixel:** Cluster of LEDs. The number and color of the LEDs depends on display application.

**Pixel Strip:** Four LED pixels mount directly onto a pixel strip. Each pixel strip is removable from the module. There are 16 pixel strips per module.

**Power Supply:** Converts AC line voltage from the load center to low DC voltage for one or more module driver boards.

**RS232:** RS232 is a standard PC communication type with a maximum cable length of 25 feet (7.6 meters)

**RS422:** RS422 is a standard differential communication type with a maximum cable length of 4000 feet (1.2 kilometers)

**Serial Port:** An actual serial port is required for direct connections through the J-box, signal converter or the radio J-box/signal converter from the computer. Certain USB adaptors create an “actual” serial port and others create “virtual” ports. Daktronics does not support the use of a USB adaptor. The Venus 1500 software will not recognize a virtual port.

**Sign Address:** The sign address is an identification number assigned to each display of a network. Rotating the address switches on the controller sets the display address. The control software uses the address to locate and communicate with each display. Displays that are on the same network cannot have the same address.

**Signal Converter:** The signal converter, shown in **Figure 4**, is a Daktronics supplied unit that converts the data from RS232 to RS422, or RS232 to fiber optic signal. The signal converter is connected to the control PC via straight through serial cable.

**Venus<sup>®</sup> 1500:** Daktronics designed, Windows<sup>®</sup> based software used to create and edit messages on the display. Refer to **ED13530** for more information.

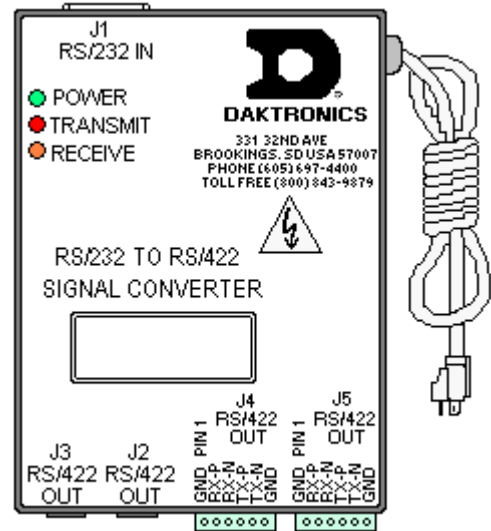

**Figure 4:** RS422 Signal Converter

## 1.5 Daktronics Nomenclature

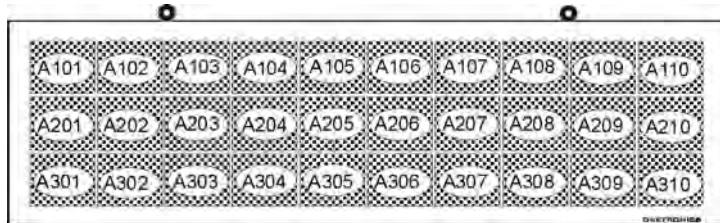

**Figure 5:** Module Numbering Example – 24x80 Front

To fully understand some Daktronics drawings, such as schematics, it is necessary to know how those drawings label various components. This information is also useful when trying to communicate maintenance or troubleshooting efforts.

A module is the building block of the display. Each module measures 8 pixels high by 8 pixels wide. By placing modules side-by-side and on top of one another, Daktronics can design and build displays of any size. **Figure 5** illustrates how Daktronics numbers modules on a Galaxy<sup>®</sup> display. **Figure 6** breaks down the module numbering method.

In addition, various Daktronics drawings may contain the following labeling formats:

- “TB\_” shows a termination block for power or signal cable.
- “F\_” denotes a fuse.
- “E\_” signifies a grounding point.
- “J\_” stands for a power or signal jack.
- “P\_” represents a power or signal plug for the opposite jack.

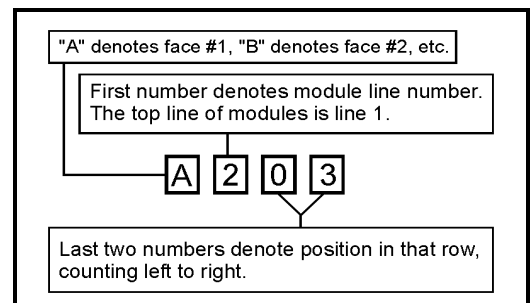
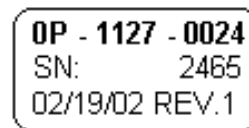

**Figure 6:** Module Numbering

Finally, drawings commonly have Daktronics part numbers. You can use those part numbers when requesting replacement parts from Daktronics Customer Service. Take note of the following part number formats:

- “OP-\_\_\_\_-\_\_\_\_” gives the form of an individual circuit board, such as a module driver.
- “OA-\_\_\_\_-\_\_\_\_” represents an assembly, such as a circuit board and the plate or bracket to which it mounts. A collection of circuit boards working as a single unit may also carry an assembly label.
- “W-\_\_\_\_” indicates a wire or cable. Cables may also carry the assembly numbering format in certain circumstances. This is especially true of ribbon cables.

Most circuit boards and components within this sign carry a label that lists the part number of the unit. If the **Replacement Parts List** in **Section 4.13** does not list a circuit board or assembly, use the label to order a replacement. **Figure 7** illustrates a typical label. The part number is in bold.



*Figure 7: Typical Label*

## Section 2: Mechanical Installation

---

**Note:** Daktronics does not guarantee the warranty in situations where the display is not constantly in a stable environment.

Daktronics engineering staff must approve **any** changes that may affect the weather-tightness of the display. If you make any modifications, you must submit detailed drawings of the changes to Daktronics for evaluation and approval, or you may void the warranty.

**Daktronics is not responsible for installations or the structural integrity of support structures done by others.** The customer is responsible to ensure a qualified structural engineer approves the structure and any additional hardware.

### 2.1 Mechanical Installation Overview

Because every installation site is unique, Daktronics has no single procedure for mounting Galaxy<sup>®</sup> displays. This section contains general information only and may or may not be appropriate for your particular installation.

**A qualified installer must make all decisions regarding the mounting of this display.**

**Read both the mechanical and electrical installation sections of this manual before beginning any installation procedures.**

### 2.2 Support Structure Design

Support structure design depends on the mounting methods, display size and weight. Since the structure design is critical, only a qualified individual should mount the display. Display height and wind loading are also critical factors. It is the customer's responsibility to ensure that the structure and mounting hardware are adequate.

**Daktronics is not responsible for the installations or the structural integrity of support structures done by others.**

**The installer is responsible to ensure the mounting structure and hardware are capable of supporting the display and agrees with local codes.**

Before beginning the installation process, verify the following:

- The mounting structure provides a straight and square frame for the display.
- The mounting structure supports the display without yielding at any unsupported points after mounting.
- Clearance: 3 " of unobstructed space is available below the display for ventilation. 1¼" of unobstructed space is available above the top of the display.

Correct any deficiencies before installation.

## 2.3 Ventilation Requirements

### Reference Drawings:

Shop Drawing ..... **Refer to Appendix A**

Fans mounted in the backsheets toward the top of the display allow for ventilation. Maintain a minimum distance of 3" (7.62 cm) below the display to maintain proper airflow. Refer to the appropriate shop drawing for additional information.

If the display cabinet is completely enclosed:

- Provide 6 square inches of unobstructed opening per module to ensure adequate cooling.
- Make allowances to compensate for the percentage of material covering the openings in the structure.
- For adequate cooling, the cabinet may require forced ventilation. If the enclosed cabinet must use forced ventilation, it must ventilate at a rate of 10 cubic feet per minute per module (28" x 28" active area).

Failure to comply with these requirements voids the Galaxy® display warranty.

## 2.4 Lifting the Display

The top of the display has eyebolts to lift the unit. Do not exceed the rated load of the eyebolts. Refer to the information at the end of this section labeled **Eyebolts** to determine the allowable load of the eyebolts shipped with the display.

**Figure 8** illustrates both the correct (left example) and the incorrect (right example) method of lifting a display. Lift the display as shown on the left, with the lifting bar. **Use every lifting point provided.**

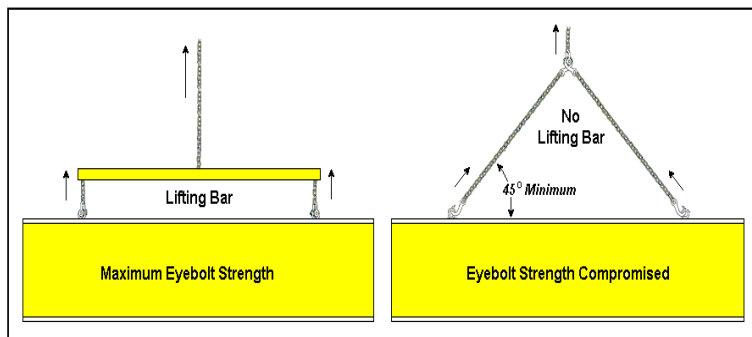

**Figure 8:** Lifting the Display (left; correct) and (right; incorrect)

**Do not attempt to permanently support the display by the eyebolts.**

If you remove the eyebolts, adequately seal the holes using 13 bolts and sealing washers, ½ inch in size. Silicone along the threads to ensure water does not enter the display.



## 2.5 Display Mounting

### Reference Drawings:

Assy, Grounding and Fan Harness .....	<b>Drawing A-175194</b>
Schematic, AF-3190-8-48x32x***-89, Mono.....	<b>Drawing A-177829</b>
Block Diagram, Power, AF-3190, 89mm .....	<b>Drawing B-175203</b>
Shop Drawings.....	<b>Refer to Appendix A</b>

The method used to mount displays varies greatly from location to location. For this reason the manual covers only general mounting topics.

**The installer is responsible to ensure the installation will adequately meet local codes and standards. The installer is also responsible for the mounting method and hardware.**

Before beginning the installation process, verify the following items:

- The mounting structure will provide a straight and square frame for the display. Height variation in any four-foot horizontal section may **not** exceed ¼- inch.
- The mounting structure will not give way at any unsupported points after the display is mounted.

The back of the display uses 3x2x<sup>3</sup>/<sub>8</sub>" steel clip angles at the locations shown in the **Shop Drawings**. These angles assist in mounting the display. Remember to have **all** mounted displays inspected by a qualified structural engineer.

The customer **must** have a qualified structural engineer review the number of attachment points needed and the wall structure to ensure both meet all national and local codes. Daktronics recommends using all clip angles as attachment points.

1. Carefully uncrate the sign. Look over each side of the display for possible damage caused during shipping.
2. Following the guidelines described in **Section 2.4**, lift the display into position on the support structure using all provided eyebolts.
3. Weld or use ½" Grade-5 bolts and hardware to secure the clip angles to the support structure as shown in **Top View** in the **Shop Drawing** for your display size. Refer to **Section 3** for information on routing power and signal.
4. **(For Sectional Displays Only):** Remove lift eyes from the bottom section. Using all lift eyes provided, lift the top section over the bottom section. Align the holes as required for 5/8" hardware. Secure sections using 5/8" hardware, as shown in the **Shop Drawings**. Connect power and signal per **Drawings A-175194, A-177829, and B-175203**. Display is then ready for installation.
5. Upon completing the installation, carefully inspect the display for any holes that may allow water to seep into the display. Seal any openings with silicone. If you remove the eyebolts on the top of the sign, plug the holes with bolts and the rubber sealing washers that you removed with the eyebolts. Silicone the threads on the bolts.

## 2.6 Optional Temperature Sensor

If you have an optional temperature sensor to be used with your display, see **Appendix C** for mounting and signal connections.

## Section 3: Electrical Installation

**Only a qualified individual should terminate power and signal cable within this Daktronics display.**

The Daktronics engineering staff must approve **any** changes made to the display. Before altering the display, submit detailed drawings for the proposed modifications to the Daktronics engineering staff for evaluation and approval or you will render the warranty null and void.

### 3.1 Common Connectors in the Display

The power and signal connections in the displays use many different types of connectors. Take special care when disengaging any connector so as not to damage the connector, the cable or the circuit board. When pulling a connector plug from a jack, **do not** pull on the wire or cable; pull on the jack itself. Pulling on the wires may damage the connector.

The following information presents some common connectors encountered during display installation and maintenance.

#### 1. Ribbon Cable Connectors:

**Figure 9** illustrates a typical ribbon connector. To disconnect the ribbon cable, push the plastic clips on the sides to unlock and remove the jack.

Before replacing a ribbon cable connector, spray it with DeoxIT™ contact cleaner to remove any foreign matter that may cause signal problems. In addition, apply a generous amount of CaiLube™ protector paste to the plug before inserting it into the jack. This paste protects both the plug and the jack from corrosion.

#### 2. Termination Blocks:

Termination blocks, as shown in **Figure 10**, connect internal power and signal wires to wires of the same type coming into the display from an external source. Most signal wires come with forked connectors crimped to the ends of the wire. Power wires need to have one-half inch of insulation stripped from the end of the wire prior to termination. Tighten all screws firmly to ensure a good electrical connection.

#### 3. Phoenix™-Style Connectors:

Phoenix-style connectors, usually green, allow for signal termination on circuit boards. Refer to **Figure 11**. Strip one-quarter inch of insulation from the wire prior to termination. To remove a wire, turn the above screw counter-clockwise to loosen the connectors grip on the wire. To insert a wire, push the bare wire into the connector and turn the above screw clockwise to lock the wire into place.

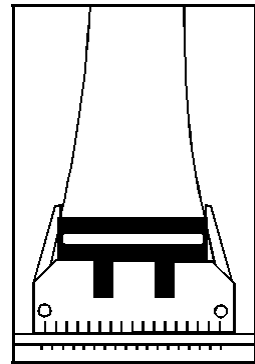

*Figure 9: Ribbon Cable Connector*

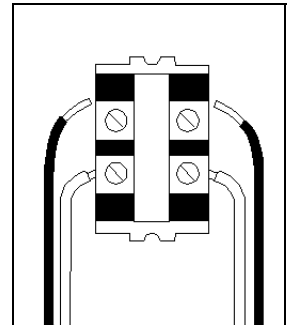

*Figure 10: Termination Block*

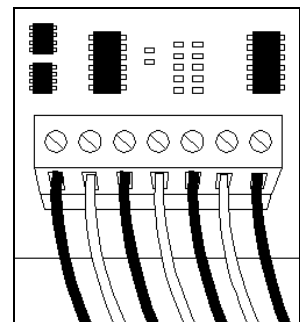

*Figure 11: Phoenix Connector*

**4. Mate-n-Lok™ Connectors:**

The white Mate-n-Lok connectors found in the displays come in a variety of sizes. **Figure 12** illustrates a five-pin Mate-n-Lok connector. To remove the plug from the jack, squeeze the plastic locking clasps on the side of the plug and pull it from the jack.

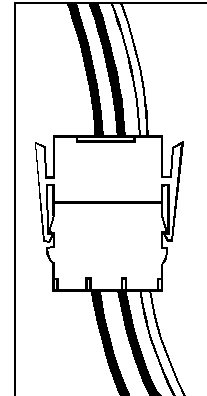

**Figure 12:** Mate-n-Loc Connector

**5. Fiber Optic Connectors:**

A fiber optic cable has a “twist-on” connector at each end. To remove the fiber plug, push it toward the board and twist it counter-clockwise until you can pull the plug from the jack. **Figure 13** shows this connector.

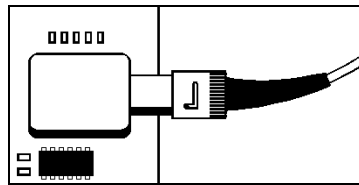
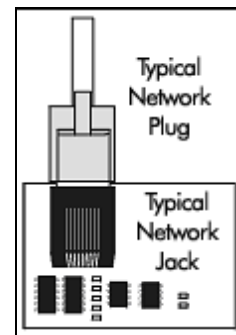

**Figure 13:** Fiber Optic Cable

**6. RJ11/RJ45 Connectors:**

RJ connectors, as seen in **Figure 14**, are similar to the telephone and LAN connectors found in homes and businesses. In order to remove this plug from the jack, depress the small clip on the underside of the plug.

Before replacing an RJ connector, spray it with DeoxIT™ contact cleaner to remove any foreign matter that may cause signal problems. In addition, apply a generous amount of CaiLube™ protector paste to the plug before inserting it into the jack. This paste will protect both the plug and the jack from corrosion.

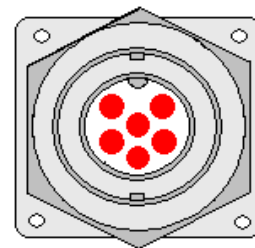

**Figure 14:** RJ45 Connector

**7. Quick Connect Jack:**

The display uses quick connect jacks for the connection of the signal termination enclosure, the temperature sensor and possible connection to an echo display. There are three input and one output quick connect jacks located on the back of the primary display, and when not used the attached dust cover should be kept closed.

To attach the cable to a jack, make sure to line up the plug to match the jack, push the plug in then turn the outer collar to lock in place. **Figure 15** illustrates the 6-pin quick connect jack.



**Figure 15:** RS232/6-pin Quick Connect Jack

## 3.2 Control Cable Requirements

### RS232

This cable is a 2-conductor shielded cable used to transmit an RS232 signal (Daktronics part number W-1117). This shielded cable should not be subjected to mechanical flexing after installation. This cable is not for direct burial and should be routed in a dedicated, grounded metallic conduit. This cable has a maximum length of 25 feet (approximately 7.6 meters).

### RS422

This cable is a 4-conductor shielded cable used to transmit an RS422 signal (Daktronics part number W-1234, Manhattan number M4473). This shielded cable consists of paired wires. They should not be subjected to mechanical flexing after installation. This cable is not for direct burial and should have one of the following routings:

- In dedicated metallic conduit, separate from the power.
- Inside buildings-if cable is not in conduit, keep away from interface signals

With interface signals (such as power conductors, intercom, etc.), typically a two-foot separation is required. The maximum length of an RS422 signal cable is 4,000 feet (approximately 1.22 km) from the signal converter to the display.

### Modem

The modem option will use standard telephone cable routed through conduit. **The phone cable and power cannot be routed in the same conduit.** The local telephone company will need to assist in this installation. Ask the telephone company which color is used for the TIP wire and which for the RING wire for signal hook up to the display.

**Note:** The telephone line must be a dedicated line and not run through a switchboard system.

### Fiber Optic

This cable is a 4-fiber cable (Daktronics part number W-1376). Two fibers are used for display communications and the other two are saved for spares. The cable may be either direct burial or routed in conduit but should not be subjected to mechanical flexing. The maximum length of a fiber optic cable is 2,000 feet (approximately 600 meters) from the signal converter to the fiber optic board in the display.

### Radio

The server radio connected to the J-box requires an 18-gauge, six-conductor shielded cable (Daktronics part number W-1370). Four-conductors will be used for the signal and two for power. These wires need to be in conduit when exposed to outdoor conditions to the server radio. The maximum distance from the RS422 J-box to the server radio is 1000 feet (approximately 330 meters).

The client radio at the display comes with a 25 foot quick connect cable that is rated for outdoor use and does not need to be in conduit. Any excess cable should be secured to protect it from weather and vandalism.

## Ethernet

**Note:** The use of a quick connect inter-connect cable or separately wired cable is not allowed between two of more displays if the input to the first display is Ethernet.

### ***Fiber Ethernet***

This cable is a 4-fiber cable (Daktronics part number W-1376). Two fibers are used for display communications and the other two are saved for spares. The cable may be either direct burial or in conduit, but it should **not** be subjected to mechanical flexing. The maximum length of the fiber optic cable from one media converter connected to the network and the second media converter in the display is 1.2 miles (approximately 2000 meters).

### ***Ethernet***

This cable is an 8-conductor network cable (Daktronics part number W-1467 Cat-5, or W-1384 Cat-5E). The cable should not be subjected to mechanical flexing after installation. This cable is not for direct burial and should have one of the following routings:

- In dedicated metallic conduit, separate from the power.
- Inside buildings-if cable is not in conduit, keep away from interface signals

With interference signal, such as power conductors, intercom, etc., typically a two-foot separation is required. The maximum length of an Ethernet signal cable is 330 feet (approximately 100 meters) from the network hub or switch to the surge board in the display.

## 3.3 RJ Connector Cables

RJ connectors are of two basic types. They consist of the RJ11 connector that uses a six-conductor cable, and the RJ45 that uses an 8-conductor cable. This type of connector can be found on many telephones and LANs.

Both the RJ11 and RJ45 cables used inside the display are pinned as straight through cables. In that case, the order of the wires is the same at both ends of the cable. Exterior cables used for a network are often flipped cables. This type of cable, as shown in **Figure 17**, has one end that is a mirror image of the other end. When installing a network, to ensure correct cabling, always install the cable from the output jack of one display to the input jack of the next display.

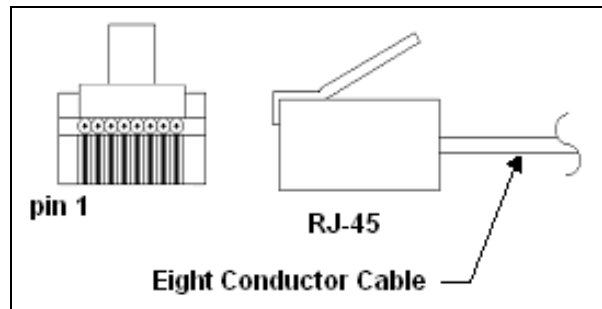

**Figure 16:** 8-Conductor RJ45 Connector and Cable

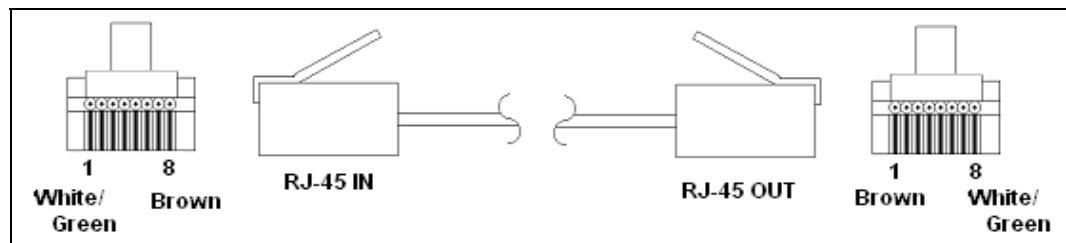

**Figure 17:** Flipped Cable with RJ Connectors

## 3.4 Conduit

### Reference Drawings:

Shop Drawings..... Refer to Appendix A

Daktronics does not include the conduit. Refer to the **Shop Drawing** for your display size for approximate locations of power and signal conduit. You must use separate conduit to route:

- Power
- Signal IN wires
- Signal OUT wires (if another sign requires signal)

Locate the conduit holes at the bottom right (rear view) of the display (refer to the **Shop Drawing** for your display.)

Punch or drill out the desired conduit openings. Be careful not to damage **any** internal components. Attach the conduit, and then route the power and signal cables.

For displays with more than one face, signal and temperature sensor wiring between displays can be routed through the same conduit.

## 3.5 Preparing for Power/Signal Connection

### Reference Drawings:

Shop Drawings..... Refer to Appendix A

If the display needs openings for the power and signal, punch out the knockouts in the lower right corner from the rear. Refer to the **Shop Drawing** for your display.

1. With a 7/32" nutdriver, apply pressure to latch and turn it a quarter-turn counter-clockwise. The module door will swing open to the left.
2. Route power to the display through a fused disconnect switch capable of opening all ungrounded power conductors. Locate this disconnect within the line of sight of any personnel performing maintenance on the display. If the disconnect is located out of sight of the display, it must be capable of being locked in the open position.
3. Power conductors from the disconnect to the display must route through conduit in agreement with local codes.
4. You may also route the signal cable from the control computer to the display at this time. **Be sure to run the power and signal cables in separate conduit.**



Figure 18: Opening the Display

## 3.6 Power

### Reference Drawings:

Layout, Pnl Bd, 8-48x32-112, 89mm, 1 Phase .....	<b>Drawing A-175209</b>
Layout, Pnl Bd, 8-48x32-112, 89mm, 3 Phase .....	<b>Drawing A-175212</b>
Schematic, AF-3190-8-48x32x***-89, Mono .....	<b>Drawing A-177829</b>
Power Specs, AF-3190, Amber LEDs .....	<b>Drawing A-178168</b>
Power Specs AF-3190, Red LEDs .....	<b>Drawing A-178240</b>

Refer to **Drawings A-178168** and **A-178240** for voltage and current requirements for your display size. Each uses a 120/240VAC single-phase or 120/208 three-phase power source.

Do **not** connect the displays to any voltage other than that listed on the Daktronics product label.

Proper power installation is imperative for proper display operation. The following sub-sections give details of display power installation. Electrical installations must be performed by qualified personnel. Unqualified personnel should not attempt to install the electrical equipment. Serious danger to equipment and personnel could occur if equipment is improperly installed.

### Grounding

Displays **must** be grounded according to the provisions outlined in Article 250 of the National Electrical Code®. Daktronics requires a resistance to ground of 10 ohms or less. Verification of ground resistance can be performed by the electrical contractor who is performing the electrical installation. Daktronics Sales and Service personnel can also perform this service

The display system **must** be connected to earth-ground. Proper grounding is necessary for reliable equipment operation. It also protects the equipment from damaging electrical disturbances and lightning. **The display must be properly grounded or the warranty will be void.**

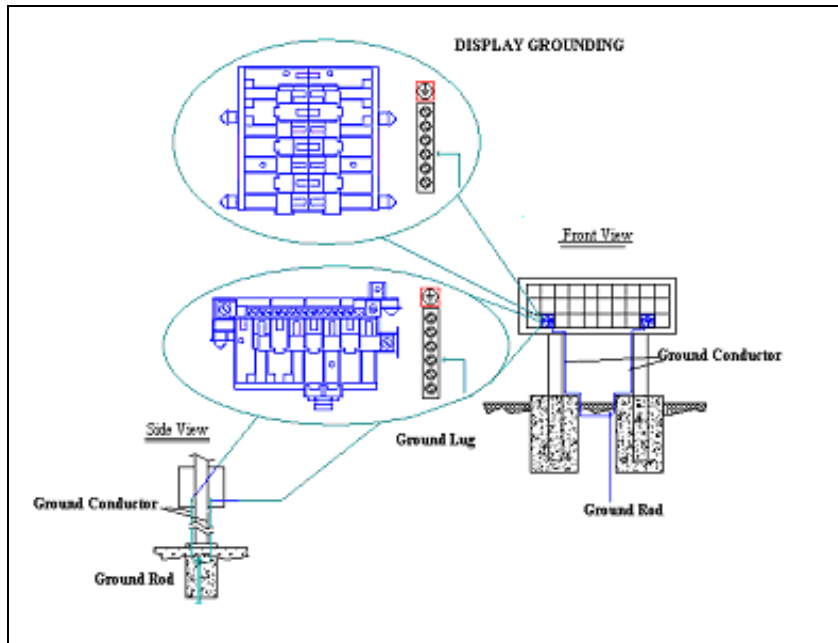

**Figure 19:** Display Grounding



A minimum of one grounding electrode must be installed for each display face. The grounding electrode is typically one grounding rod for each display face. Other grounding electrodes as described in Article 250 of the National Electric Code may be used. Daktronics requires that the resistance to ground be 10 ohms or less. If the resistance to ground is higher than 10 ohms, it will be necessary to install additional grounding electrodes to reduce the resistance. The grounding electrode should be installed within 25 feet of the base of the display. The grounding electrode must be connected to the ground terminal in the display panel board.

This grounding electrode must be installed in addition to the equipment-grounding conductor that should be part of the power installation. The material of an earth-ground electrode differs from region to region and from conditions present at the site. The support structure of the display cannot be used as an earth ground electrode. The support is generally embedded in concrete, and if in earth, the steel is either primed or it corrodes, making it a poor ground. The grounding system and grounding electrodes must be installed according to Article 250 of the National Electrical Code and any applicable local codes.

## **Power Installation**

There are two considerations for power installation: installation with ground and neutral conductors provided and installation with only a neutral conductor provided. For these displays, installation with ground and neutral conductors provided is used.

### **Installation with Ground and Neutral Conductors Provided**

For this type of installation, the power cable **must** contain an isolated earth-ground conductor. Under this circumstance, **do not** connect neutral to ground at the disconnect or at the display. This would violate electrical codes and void the warranty. Use a disconnect so that all hot lines and neutral can be disconnected. The National Electrical Code requires the use of a lockable power disconnect within sight of or at the display.

### **Main Disconnect**

The National Electrical Code requires the use of a lockable power disconnect near the display. Provide a lockable disconnect switch (knife switch) at the display location so that all power lines can be completely disconnected. Use a 3-conductor disconnect to disconnect both hot lines and the neutral. Mount the main disconnect at or near the point of power supply connection to the display. Provide a main disconnect for each supply circuit to the display.

You must locate the means of disconnection in a direct line-of-sight from the display or outline lighting that it controls. This requirement provides protection by enabling a worker to keep the disconnecting means within view while working on the display.

**Exception:** You may locate the disconnecting means that are capable of being locked in the open position elsewhere.

### 3.7 Signal Termination from Computer to Sign

**Note:** The AF-3190 is designed for quicker connection to other displays and other additional equipment. Connection of the control computer to the first display needs to be wired to the surge suppressor, modem, or fiber optic board in the display. Depending on the communication type ordered the following cables may be provided with the display:

1. Interconnect cable from primary to echo, length 10 feet.
2. Temperature sensor with quick connect cable, length 10 feet.
3. Client radio with quick connect cable, length 25 feet.

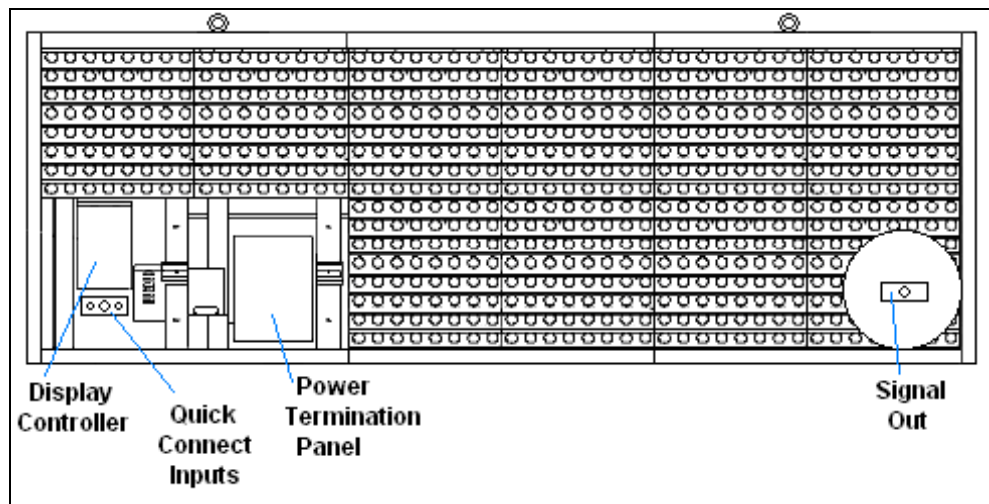

Figure 20: Signal Termination Locations

#### RS232

##### Reference Drawings:

- System Riser Diagram, RS232 ..... **Drawing A-174341**
- Schem, Sig Wiring, Internal, W/quick Connect PCB ... **Drawing B-177662**
- Controller, Galaxy, 8 Conn., J1087 ..... **Drawing B-177838**

A display that is controlled using RS232 requires the use of a J-box within 25 feet of the display. From the J-box to the display, the signal will be wired directly to the controller inside the display. The cable from the J-box to the display must be routed through conduit. **Do not** run signal and display power through the same conduit.

1. Terminate one end at the J-box and the other end of the wire to the 6-position terminal block on the controller labeled “RS232 IN” (TB1).
2. **Figure 22** and **Drawing B-177662** shows the terminal block wiring. **Drawing B-177838** shows the controller.
3. The controlling laptop computer connects to the J-box through a DB9 to DB25 serial cable (W-1249) (refer to **Drawing A-174341**).

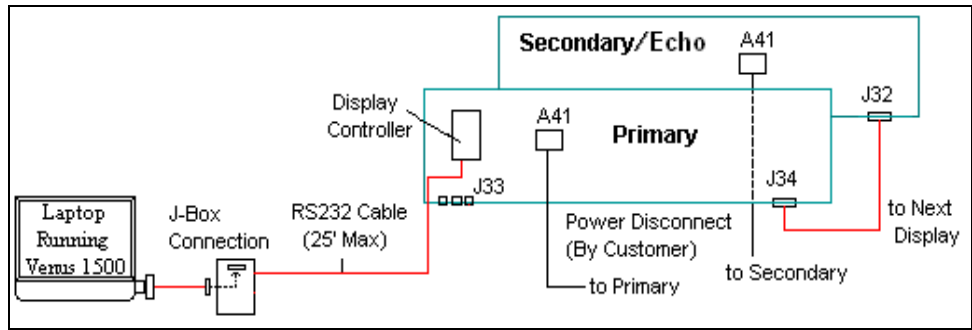

Figure 21: RS232 Display Layout

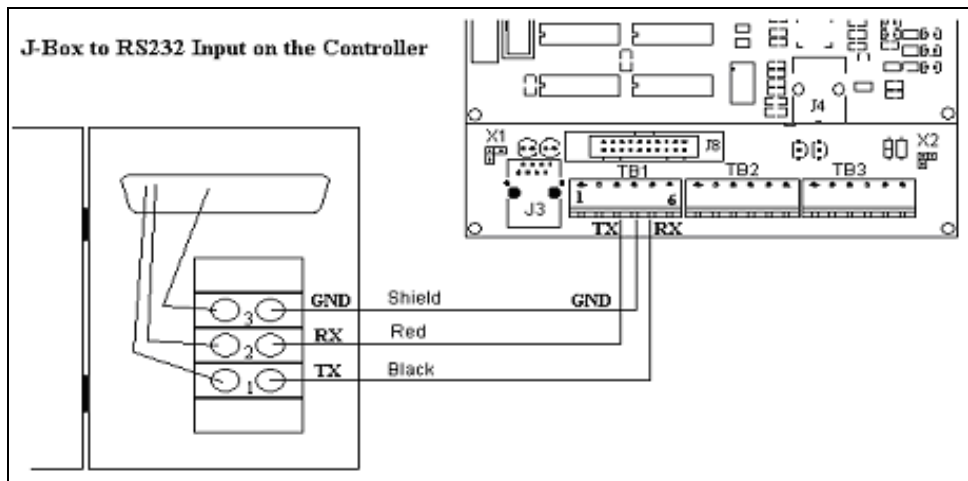

Figure 22: J-box to RS232 Input on the Controller Board

**J-Box to Controller Board**

J-Box	Field Cabling	Controller Board TB1 (RS232 In)
Pin 1 (TX-P)	Black	Pin 5 (RX-1)
Pin 2 (RX-P)	Clear/Red	Pin 3 (TX-1)
Pin 3 (GND)	Shield	Pin 4 (GND-N)

**RS422**

**Reference Drawings:**

- System Riser Diagram, RS422 ..... **Drawing A-174135**
- Schem, Sig Wiring, Internal W/Quick Connect PCB.... **Drawing B-177662**

A display that is controlled using RS422 requires the use of signal converter at the computer. From the signal converter, cable is run to the surge board assembly in the display. The cable from the signal converter to the display must be routed through conduit. **Do not run signal and display power through the same conduit.** Refer to **Figure 23** and **Drawing A-174135** for system layout.

1. When connecting to the surge card in the display, terminate one end at signal converter (0A-1127-0255) and the other end of the wire to the 6-position terminal block on the surge board assembly (0P-1146-0031) labeled "RS422 IN" (TB1).

2. **Figure 24** and **Drawing B-177662** shows the terminal block wiring. The terminal block wiring is pinned one-to-one.
3. The computer connects to the signal converter through a DB9 to DB25 serial cable (W-1249).

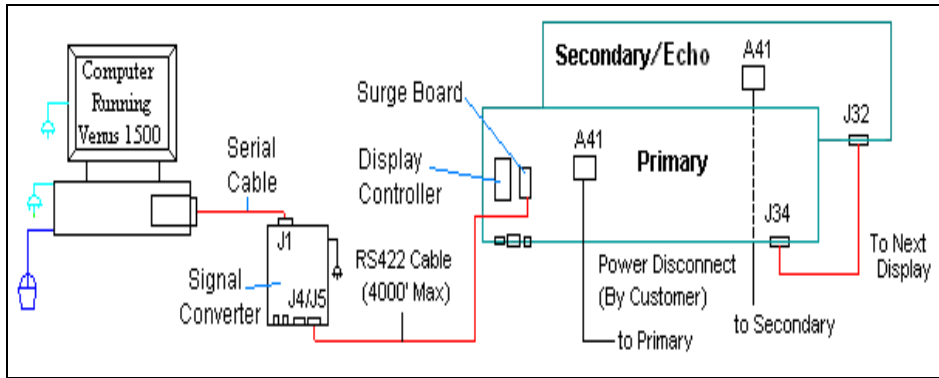

**Figure 23:** RS422 Display Layout

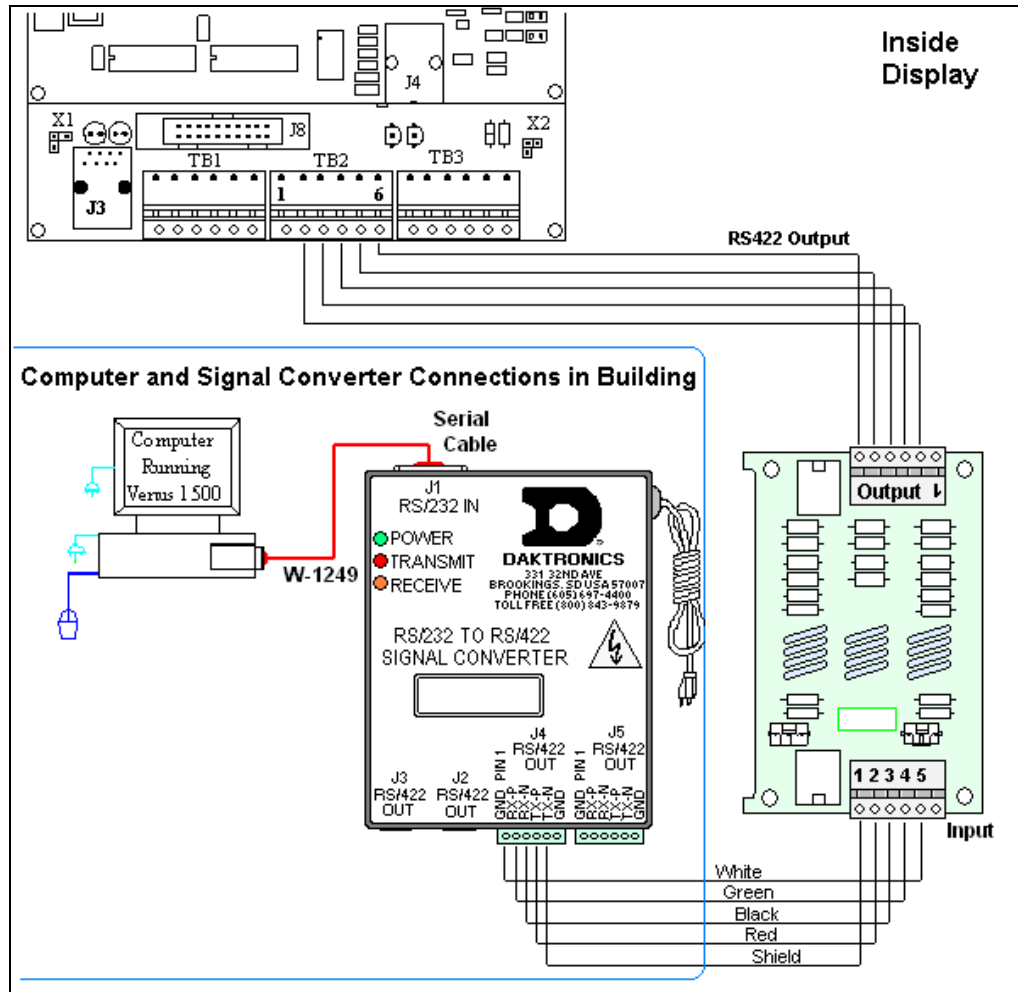

**Figure 24:** Signal Converter to Surge Board in Display

### Signal Converter to Surge Board Assembly

Signal Converter (J4/J5)	Field Cabling	Surge Board Assembly TB1 (RS422 In)
Pin 1 (GND)	Shield	Pin 1 (A GND)
Pin 2 (RX-P)	Red	Pin 2 (D1OUT-P)
Pin 3 (RX-N)	Black	Pin 3 (D1OUT-N)
Pin 4 (TX-P)	Green	Pin 4 (D1IN-P)
Pin 5 (TX-N)	White	Pin 5 (D1IN-N)
Pin 6 (GND)		Pin 6 (A GND)

### Modem

#### Reference Drawings:

System Riser Diagram, Modem ..... **Drawing A-174342**

Schem, Sig Wiring, Internal, W/QC PCB ..... **Drawing B-177662**

A display that is controlled using a modem requires the use of an internal or external modem at the computer. The local phone company must provide a dedicated phone line to the display and identify which color wire is used for “Tip” and which color for “Ring”. The phone cable must be routed through conduit. **Do not** run phone line and display power through the same conduit. Refer to **Figure 25** and **Drawing A-174342** for system layout.

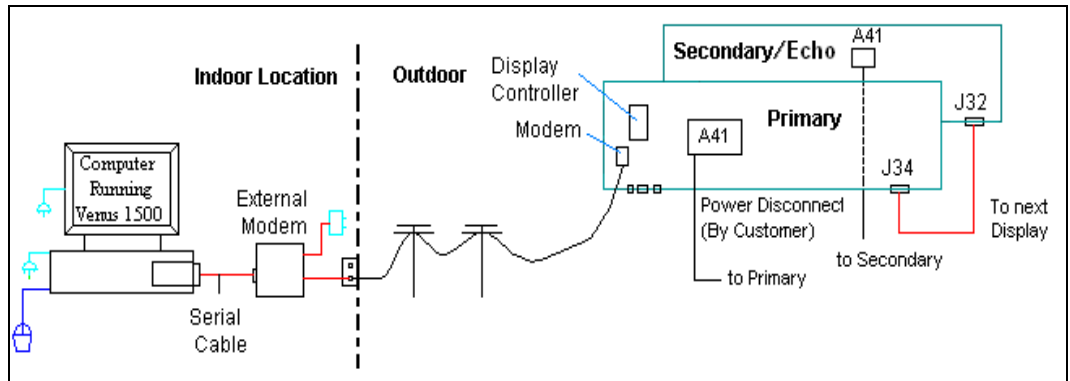

**Figure 25: Modem Display Layout**

1. When connecting to the modem in the display, terminate the phone line to TB2 on the display modem (0P-1279-0003). If the phone company provided a phone termination box in the display a straight phone cable can be connected from the box to the J5 Phone IN on the modem board in the display.
2. **Figure 26** and **Drawing B-177662** shows the terminal block wiring.
3. A second cable (Daktronics part number 0A-1229-0054) transfers data from J6 on the modem to J3 (RS232 IN) on the controller.

**Note:** The jumper XI on the controller board must be **closed** to recognize that a modem is being used with the display. The presence of a modem will be displayed as part of the bootup sequence.

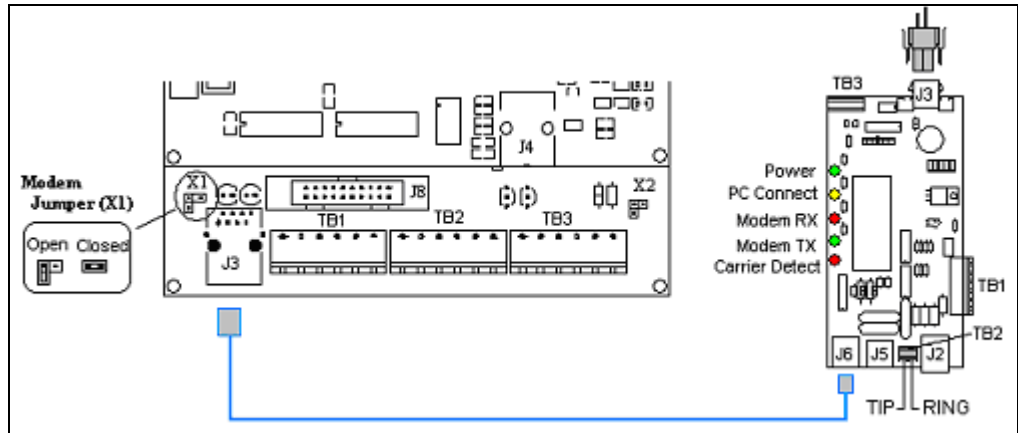

Figure 26: Modem Connection Locations

## Fiber Optic

### Reference Drawings:

System Riser Diagram, Fiber..... **Drawing A-174344**

Schem, Sig Wiring, Internal, W/QC PCB..... **Drawing B-177662**

When using fiber cable, the cable will connect directly from the signal converter to the fiber optic board in the display. Refer to **Figure 27** and **Drawing A-174344** for the system layout

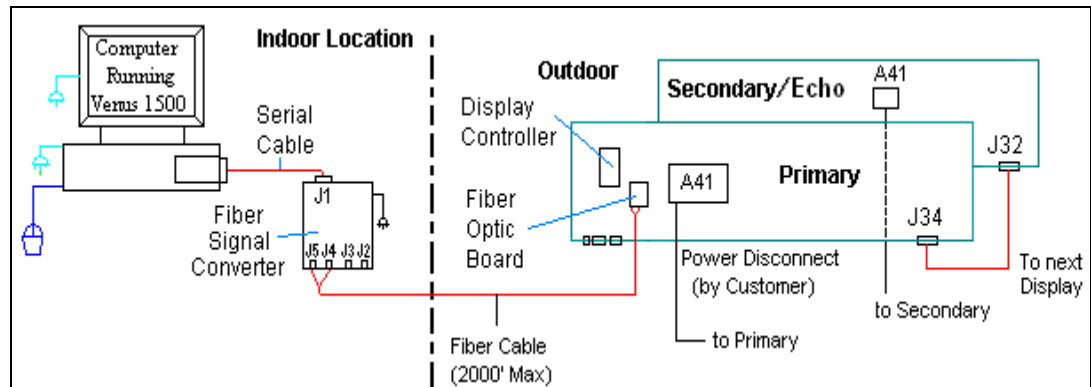

Figure 27: Fiber Display Layout

1. Connect the two fibers at the signal converter (0A-1127-0256) and the other two at the fiber optic board (J4/J5) (OP-1146-0024) in the display. Always remember to connect TX to RX and RX to TX. (Either pair of fiber outputs on the signal converter can be used, but only the left pair of inputs on the fiber optic board.)
2. Refer to **Figure 28** and **B-177662** for cabling in the display.
3. A 8-conductor cable with RJ45 connectors (0A-1229-0054) then relays the signal from J7 on the fiber optic board to J3 (RS232 IN) on the controller
4. The computer connects to the signal converter through a DB9 to DB25 serial cable (W-1249).

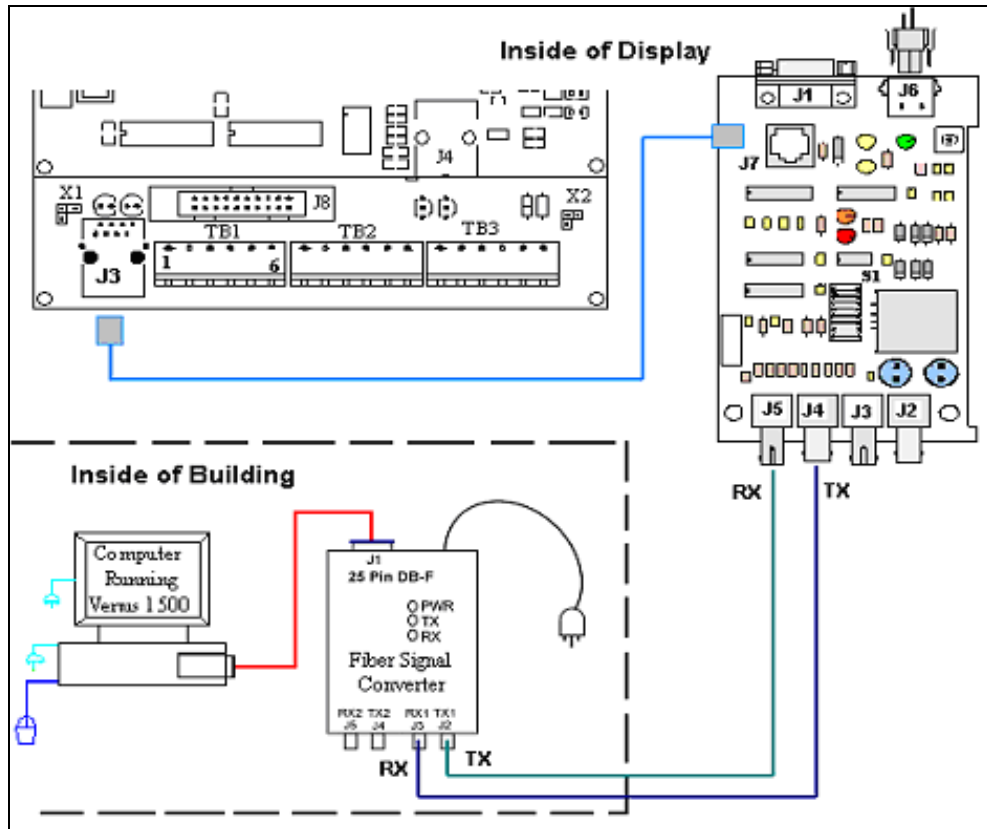

Figure 28: Fiber Signal Connections

### Signal Converter to Fiber Board

Signal Converter	Field Cabling	Fiber Board
J2 (TX1)	(Color varies)	J5 (RX)
J3 (RX1)	(Color varies)	J4 (TX)

### Venus® 1500 Radio Client

#### Reference Drawings:

System Riser, QC Outdoor Radio, Gen 2 .....**Drawing A-185359**

Schem, Sig Wiring, Internal, W/Q CPCB.....**Drawing B-177662**

A display that is controlled using a radio requires a server radio connected to the control computer, and a client radio connected to the display using a pre-terminated cable. The following conditions are required for good radio operation:

1. The radios must be within line-of-sight of each other.
2. The total distance between the outdoor radios should not exceed 1500 feet.
3. The antennas for the server and client radio should be in a parallel position with each other.

Refer to **Drawing A-185359** and **Figure 29** for system layout.

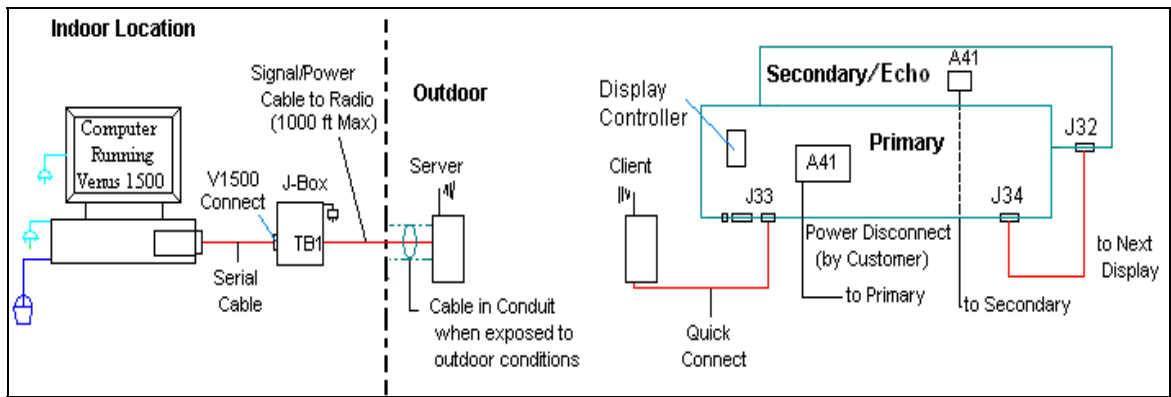

**Figure 29:** Radio Display Layout

1. The computer connects to the J-box/signal converter (0A-1279-0161) at the connector labeled “V1500 PC Connect”. Use a DB9M to DB9F serial cable (W-1267).
2. Use an 18 AWG, 6-conductor, cable to connect from the J-box/signal converter to the server radio (0A-1146-0079) mounted on the outside of the building. The cable is pinned one-to-one. (Additional drawings for the server connections are in the Venus 1500 Radio Manual, **ED13932**.)
3. The client radio (0A-1146-0078) is provided with 25 feet of weather resistant pre-terminated cable. The cable will be terminated to the display with the quick connect plug to the top, red jack, labeled J33, on the display. Refer to **Figure 30** for the quick connect termination point.
4. One end of the cable is pre-terminated to TB2 inside the radio enclosure, and a quick connect plug is terminated at the other end of the cable.

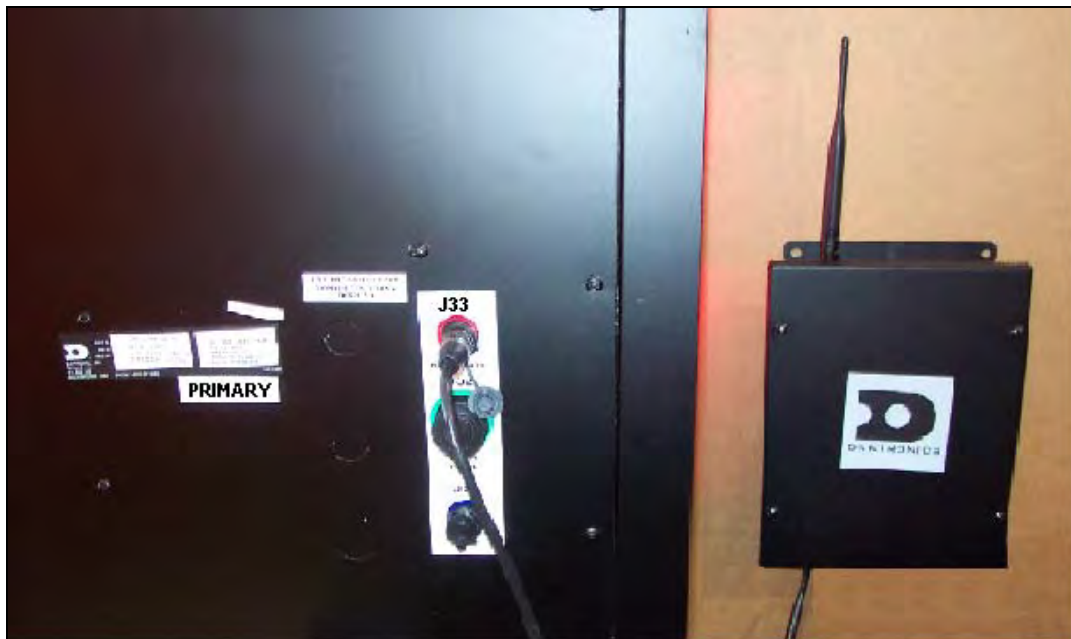

**Figure 30:** Client Radio to Display



## Ethernet (Wire)

The controller has a default IP address of 172.16.192.25. Use this address to connect to the primary display, and then it can be changed to an address specified by the network administrator. **Electrical surges may enter over the cable; it is the customer's responsibility to protect their network.**

An Ethernet controlled display, requires the use of an RJ45 cable from the network to the display with the following connections:

1. Connect one end of the RJ45 cable to a network hub or switch
2. From the network connection, cable is run to the Ethernet surge card in the display.
3. The cable from the Ethernet hub to the surge board in the display must be routed through conduit. **Do not** run signal and power through the same conduit. Refer to **Figure 31** for system layout.
4. **Note:** Ethernet signal into the display **does not** allow for standard RS422 output signal to a second primary display. This includes the use of an interconnect cable or separate wiring between displays.

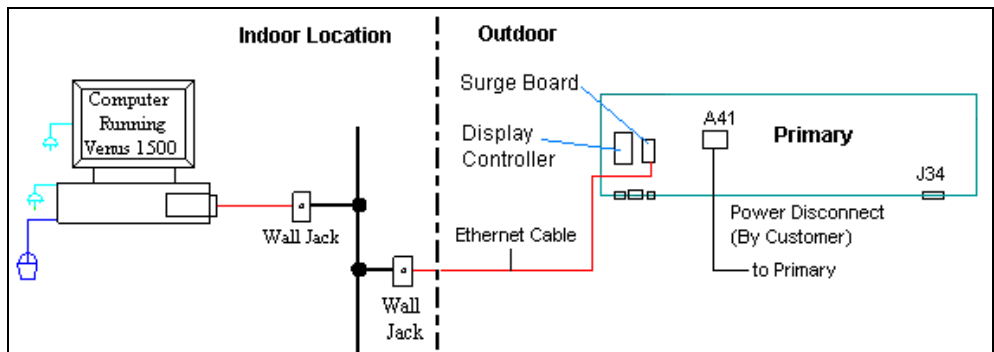

**Figure 31:** Ethernet Display Layout

An Ethernet controlled display, uses a Cat-5 (W-1467) or Cat-5E (W-1384) cable routed through separate conduit to the display. The maximum distance is 330 feet (100 meters).

1. Connect from the Ethernet port on the computer into the Ethernet wall jack.
2. Run the cable through separate conduit into the display and connect to J1 on the Ethernet surge board (0P-1229-2012) as shown in **Figure 32**.
3. A five-foot RJ45 cable (W-1506) connects for the J2 output on the surge card to the Ethernet port on the controller.
4. **Note:** It is the customer's responsibility to protect their network from surges back to their network.

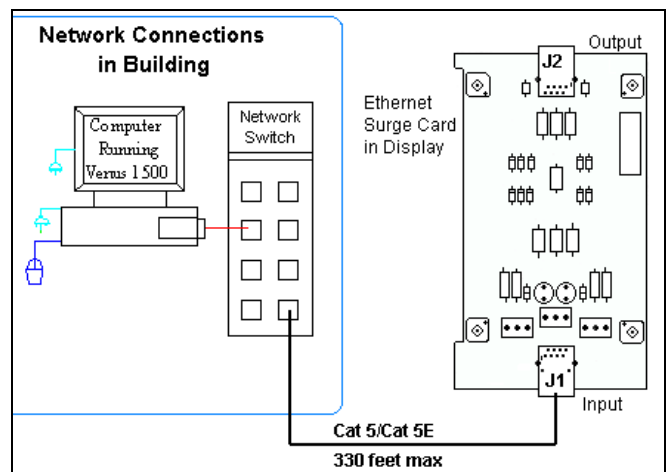
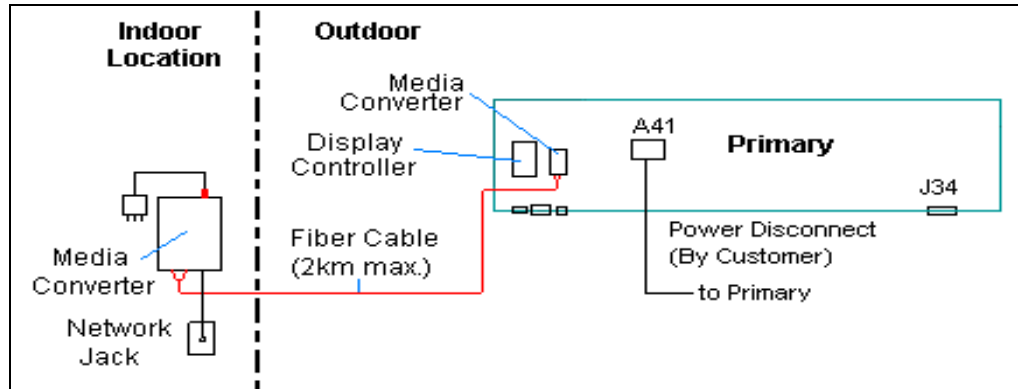

**Figure 32:** Ethernet Signal Connection

## Ethernet (Fiber)

The controller has a default IP address of 172.16.192.25. Use this address to connect to the primary display, and then it can be changed to an address specified by the network administrator. **Note:** Ethernet signal into the display does not allow for standard RS422 output signal to a second primary display. This includes the use of an interconnect cable or separate wiring between displays.

A fiber Ethernet controlled display requires the use of two media converters connected by a fiber cable. The first media converter is connected to the network and the second one is connected to controller in the display as shown in **Figure 33**.



**Figure 33:** Fiber Ethernet Layout

A fiber Ethernet controlled display requires the following connections:

1. A media converter (A-1778) connects to the network hub or switch using an RJ45 network cable.
2. A DC wall pack transformer provides power to the media converter from a 120 VAC outlet.
3. Connect the fiber cable from the two jacks on the first media converter to the two jacks on the second media converter in the display. (Always connect transmit on one media converter to receive on the second, and receive to transmit.)
4. The media converter in the display connects to the controller via an RJ45 cable (W-1506). It also receives power from pins one and four of TB1 on the controller.
5. The Ethernet connections are shown in **Figure 34**.

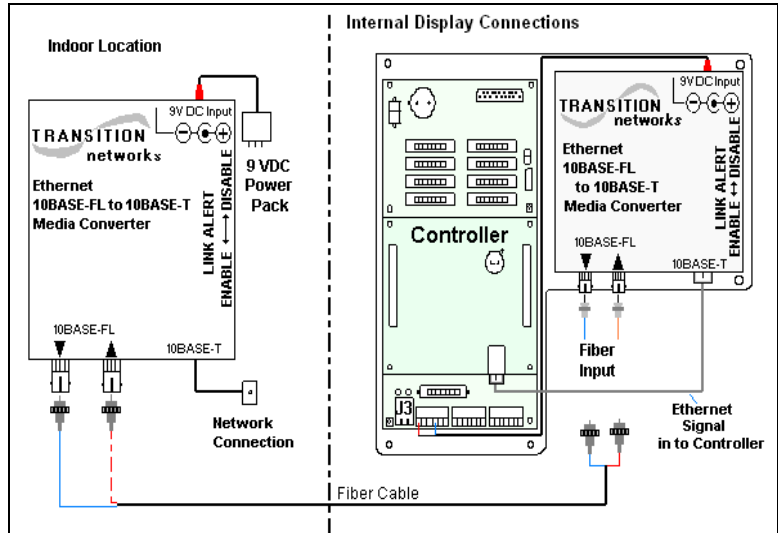

**Figure 34:** Fiber Ethernet Signal Connections

## RS422 Interconnection

The quick connect cable is the most common method of terminating signal between two displays. The interconnect cable goes from the RS422 OUT on the first display to the RS422 IN on the second display. The 10-position, quick connect cable comes in either 6 or 10 foot lengths.

If the displays are not back-to-back, or are too far apart for the quick connect interconnect cable to reach, a 4-conductor shielded cable of the correct length is used. One end will connect at the “RS422 OUT” 6-position controller board terminal block (TB3) in the first display, and terminate on the “RS422 IN” 6-position controller board terminal block (TB2) on the second display.



Figure 35: Display Interconnect Cable

**Note:** If a temperature sensor is also used, a separate cable must also be used to connect between controllers. **Appendix C** explains the connections for a temperature sensor.

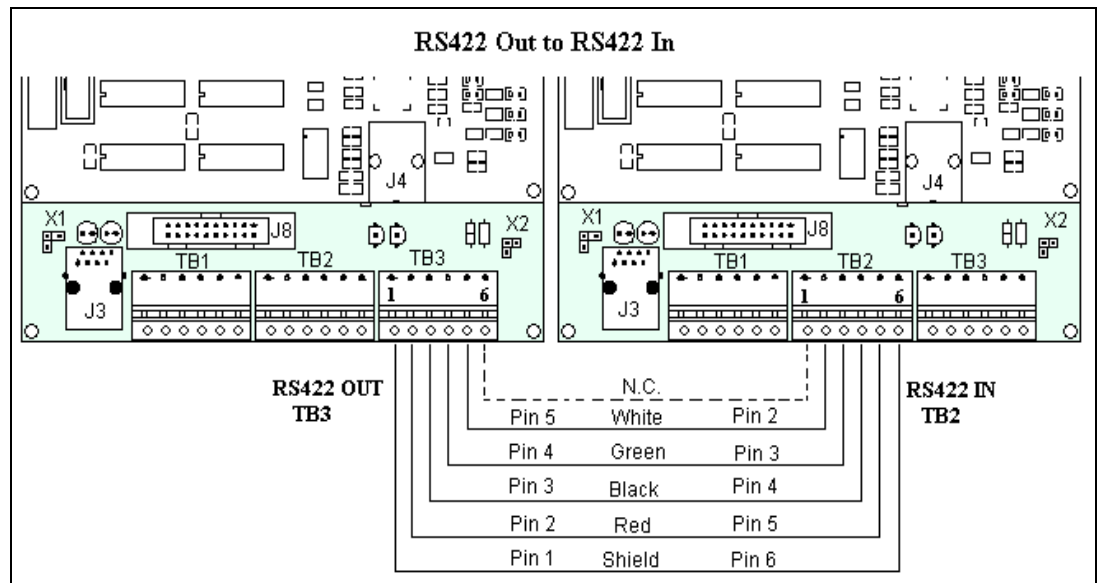

Figure 36: RS422 Interconnection

### RS422 Interconnection

Face A RS422 Out (TB3)	Field Cabling	Face B RS422 IN (TB2)
Pin 1 (GND)	Shield	Pin 6 (GND)
Pin 2 (D2OUT-N)	Red	Pin 5 (D1IN-N)
Pin 3 (D2OUT-P)	Black	Pin 4 (D1IN-P)
Pin 4 (D2IN-N)	Green	Pin 3 (D1OUT-N)
Pin 5 (D2IN-P)	White	Pin 2 (D1OUT-P)
Pin 6 (Shield)		Pin 1 (Shield)

**Note:** When not using the quick connect interconnect cable; cabling must be in conduit between displays.

## Fiber Interconnection

A four-conductor fiber cable is used in connecting two or more displays in the Fiber Interconnection method. Two fibers will be used for the connection and two will be saved for spares. Connect the fiber cable to the fiber cards in the displays as described in **Drawing A-174344** and in the following table. The two jacks on the left side of the fiber optic board (J2 and J3) will be used on the first display and the two on the right side of the board (J4 and J5) will be used in on the second display. Always connect transmit to receive and receive to transmit.

**Fiber Interconnection**

Face A Data Out	Field Cabling	Face B Data In
J2 Transmit (TX1)	Color Varies	J5 Receive (RX2)
J3 Receive (RX1)	Color Varies	J4 Transmit (TX2)

## 3.8 Optional Temperature Sensor

If you have an optional temperature sensor to be used with your display, see **Appendix C** for mounting and signal connections.

## 3.9 First Time Operation

Each time the display is powered up; the display will run through an initialization in which it will display the following:

1. Product Name (Galaxy®)
2. Display Size (Row x Column)
3. Shading (64 Mono)
4. Bootloader Version (OS X.XX)
5. Firmware Number (**ED13305**)
6. Firmware Revision (Rev X.XX)
7. Hardware Address (HW:XX)
8. Software Address (SW:XX)
9. IP Address: ((default) 172.16.192.25)
10. Subnet Msk: ((default) Msk: 255.255.0.0)
11. COM1 Configuration (C1:V15) ((Modem C1:V15) If a Modem is present)
12. COM 2 Configuration (C2:RTD)
13. Socket 3001: (IP 3001: V15)
14. Socket 3002: (IP 3002: RTD)
15. Line Frequency (CLK: AUTO 60 Hz)
16. Display Name Description (Galaxy Row x Column)

After this sequence is complete, the display will blank. A single pixel will flash in the lower right hand corner of the display to show that the display has power, but no messages are currently running.

# Section 4: Maintenance and Troubleshooting

---



## Important Notes:

1. **Disconnect power before performing any repairs or maintenance work on the sign!**
2. **Only qualified service personnel may access internal sign electronics.**
3. **The Daktronics engineering staff must approve ANY changes made to the sign. Before altering the sign, you must submit to the Daktronics engineering staff detailed drawings for the proposed modifications for evaluation and approval or you will void the warranty.**

## 4.1 Maintenance and Troubleshooting Overview

Daktronics Galaxy® series AF-3190 signs are front accessible, meaning you can only access the internal components from the front of the sign.

This section provides the following Galaxy® sign information:

- **Recommended Tools List** provides a listing of all tools needed in order to perform maintenance work on your display
- **Signal Routing Summaries** give a basic explanation of how the signal travels through the sign.
- **Power Routing Summaries** show a basic explanation of how the power travels through the sign.
- **Service and Diagnostics** offer instructions for removing various sign components and explains the functions of circuit board connectors and the meanings of any diagnostic LEDs.
- **Maintenance** lists a number of steps to take to keep this Galaxy® sign in safe, working order.
- **Troubleshooting** presents some possible sign malfunctions and provides a number of possible causes for that malfunction.
- **Replacement Parts List** includes the part description and number of sign components that could possibly need replacing during the life of this sign.
- **Daktronics Exchange and Repair and Return Programs** explain the Daktronics component return policy.

## 4.2 Recommended Tools List

When performing maintenance work on your display, Daktronics recommends using the following tools and placing them in a convenient, easy-access location.

- **7/32" Nut Driver** to open the modules in front access displays
- **3/16" Nut Driver** to remove screws from the signal communication boards.
- **7/16" Wrench** removes support hardware from power supplies
- **#2 Phillips Screwdriver** removes support hardware from power supplies and detaches power supplies

## 4.3 Signal Summary

### Reference Drawings:

Schematic, AF-3190-8-48x32x\*\*\*-89, Mono ..... **Drawing A-177829**

The signal routing for the display can be summarized as follows:

1. Data from the controller computer, which runs Venus<sup>®</sup> 1500 software, travels via RS232, RS422, modem, fiber optic cable, radio, or Ethernet signal into the display.
2. From the controller, the signal then travels over a 20-conductor ribbon cables from the controller (J11 through J16 provides signal out) to J2 on the driver of the first column of modules in the display.
3. Data exists at J1 and is relayed to J2 of the next driver board and so on, traveling down the entire row of modules.
4. For multiple face display or a display network, an RS422 (most typical) or fiber cable relays signal between the controller of the first display and the controller in the second display. **Note:** The RS422 interconnection is not allowed when the input to the first display is Ethernet.
5. Refer to **Drawing A-177827** and **Figure 37** for further information. The drivers use this display data to control the LEDs.

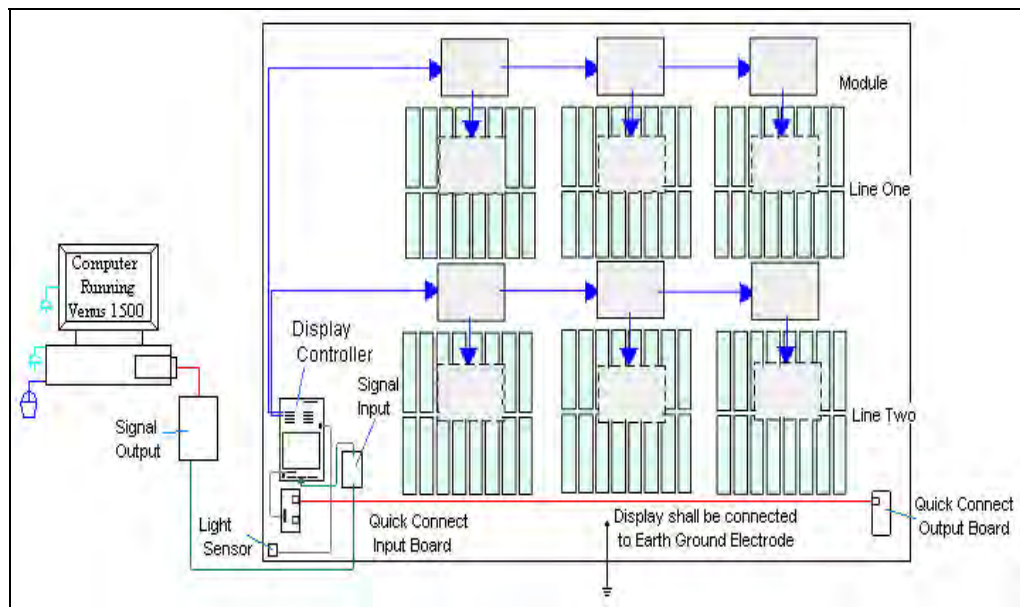

Figure 37: AF-3190 Signal Flow Diagram

## 4.4 Power Summary

### Reference Drawings:

Schematic; Power Supply Configurations ..... **Drawing A-158225**

Schematic, AF-3190-8-48x32x\*\*\*-89, Mono ..... **Drawing A-177829**

The following describes the internal display power routing for the display:

1. Incoming power terminates at the panel board.
2. 120 VAC power is then relayed to the power supplies in the display, which convert the power to DC voltage.

3. +12VDC power supplies power the modules in a monochrome red display and +14.7VDC power supplies power the modules in a monochrome amber display. Refer to **Drawings A-158225** and **A-177829** for power supply wiring information.
4. Power is also sent to the fans which cool the display and the transformer that provides power to the controller and some additional communication boards (modem, fiber, radio, or fiber Ethernet).

## 4.5 Display Access

Display access for 89mm displays is normally from the front. To open the sign:

1. Locate the latch access fastener on the module. It is centered on the right side of the module.
2. With a 7/32" nutdriver, apply pressure to latch and turn it a quarter-turn counter-clockwise. The module door will swing open to the left.
3. Interior display components may be accessed and the pixel strips may be removed.



**Figure 38:** *Opening the Display*

When closing a display, reverse the previous steps and take note of the following points:

- The weather-stripping on the back edge of the module is intact and in good condition for preventing water from seeping into the sign.
- The module latches are fully engaged to create a water resistant seal around the edge of the module. The module **must** be firmly seated against the sign when the latches are fully engaged.

## 4.6 Service and Diagnostics

### Reference Drawings:

Component Layout, AF-3190-\*\*X\*\*- 89mm.....**Drawing B-181666**

The following sub-sections address servicing of the below display components:

- Line filter and ground bar
- Modules, drivers, and power supplies

The sub-sections also address any diagnostic LEDs, fuses and signal/power connectors found on the components.

**Drawing B-181666** denotes the components as follows:

Component...	Denoted As...	Location...
Line Filters and Ground Bar	0A-1259-4003	Left side, behind module AX02
Modules	0A-1259-3104 or 0A-1259-3105	Over entire face of the display
Power Supplies	0A-1259-4402 0A-1259-4405	Behind the modules; refer to <b>Drawing B-181666</b>

## Line Filter

### Reference Drawings:

Z Filter Assy, 2 W/Grnd Bar..... **Drawing A-158472**  
Schematic, AF-3190-8-48x32x\*\*\*-89, Mono ..... **Drawing A-177829**

You can replace the line filter by first labeling and removing all connecting wires, and then releasing the attachment hardware. Refer to **Drawing A-158472**. Install the new filter and reference **Drawing A-177829** for correct wiring.

## Modules, Pixel Strips and Drivers

### Reference Drawing:

Driver Assy; AF-3190-8x8-89mm-Mono..... **Drawing A-178210**  
Module Panel, AF-3190-8x\*-89mm-Amber ..... **Drawing B-178218**  
Module Panel, AF-3190-8x8-89mm, Red..... **Drawing B-178220**

A module consists of louvers, 16 pixel strips per module, and a driver board mounted to the back. Refer to **Section 4.5** to open a display and access the modules, pixel strips, and driver boards. Refer to **Drawings B-178218** and **B-178220** for module assembly.

A pixel strip is a circuit board with four LED pixel clusters mounted directly on it. Each pixel strip is removable from the module. To remove a pixel strip from the module:

1. Open the display as described in **Section 4.5**.
2. Disconnect the power and signal connector from the strip you wish to replace.
3. If the pixel strip you wish to replace is located behind the driver assembly, unplug all signals and power connections on the driver assembly and remove the four corner screws. Refer to **Drawing A-178210**.
4. Remove the six wing nuts holding the pixel strip in place.
5. Gently lift the strip from the display.
6. Reverse the above procedure to install a new pixel strip.

The driver is a circuit board responsible for switching the intensity levels of the LEDs. It is located inside the driver box and mounts on the back of the module. To remove a driver board:



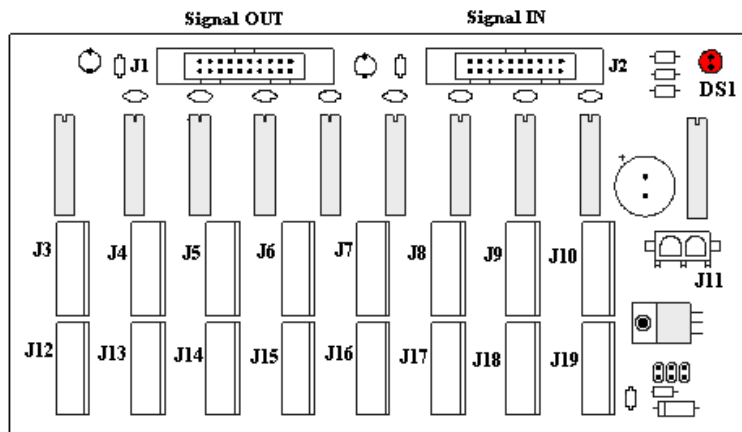

**Figure 39:** Driver Board

1. Open the display as described in **Section 4.5**.
2. Loosen the two #10 screws holding the driver cover in place.
3. Lift the cover off from the assembly. Refer to **Drawing A-178210**.
4. Disconnect all power and signal connections from the driver board.
5. Remove the four #6 nuts holding the board in place.
6. Gently lift the board from the display.
7. Reverse the above procedure to install a new driver board.

The following connectors are found on each driver board; refer to **Figure 39**:

LED/Connector	Function
J1	Signal out to next driver board
J2	Signal in
J3-J10, J12-J19	Output to pixel strips
J11	Power
DS1	Power indicator

The connectors out to the pixel strips connect to the pixel strips in the following manner:

Connector	Pixel Strip Coordinates	Connector	Pixel Strip Coordinates
J3	Top Row, Column 8	J12	Bottom Row, Column 8
J4	Top Row, Column 7	J13	Bottom Row, Column 7
J5	Top Row, Column 6	J14	Bottom Row, Column 6
J6	Top Row, Column 5	J15	Bottom Row, Column 5
J7	Top Row, Column 4	J16	Bottom Row, Column 4
J8	Top Row, Column 3	J17	Bottom Row, Column 3
J9	Top Row, Column 2	J18	Bottom Row, Column 2
J10	Top Row, Column 1	J19	Bottom Row, Column 1

## Controller

### Reference Drawings:

Controller, Galaxy, 8-conn, J1087 ..... **Drawing B-177838**

The controller sends data to the modules. Refer to the signal summary in **Section 4.3** for more information and to the component location drawings for the position of the controller board. **Figure 40** and **Drawing B-177838** illustrate a typical controller.

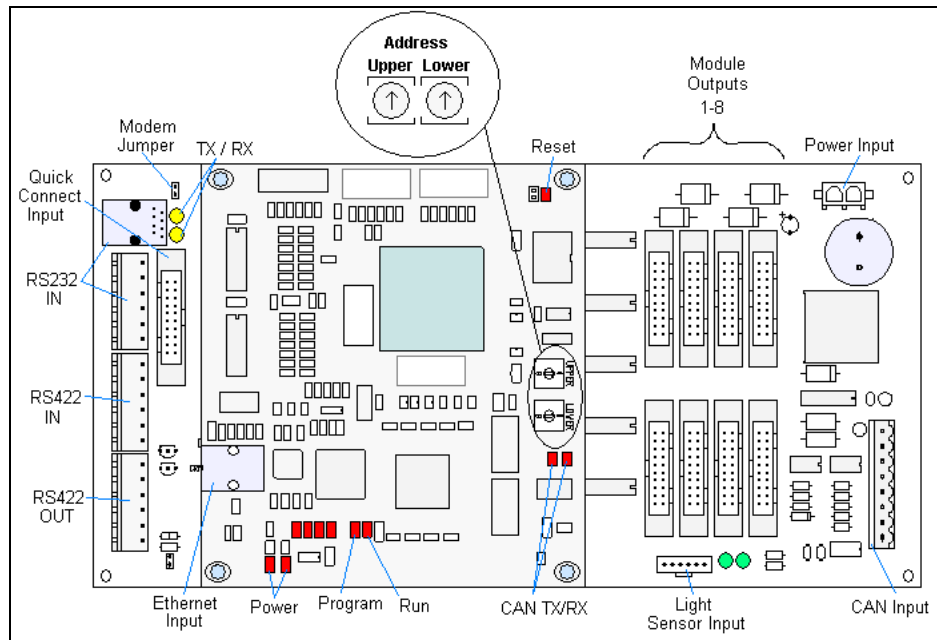

**Figure 40:** Controller

The rotary switches set the hardware address, which the software uses to identify that particular display. When replacing a controller board, be sure to set the rotary switches in the same address configuration as the defective controller. Each controller in a network needs a unique address.

Complete the following steps to remove the controller from the display:

1. Disconnect power from J5.
2. Remove all power and signal connections from the board. “Locked” connectors are released by pushing apart the latches, and then carefully pulling them from the jack. When replacing the board, it is helpful to have the cables labeled for easier replacement.
3. Remove each of the six screws holding the board in place with a 3/16” nut driver.
4. Follow the previous steps in reverse order to install a new controller board.

The rotary switches follow a standard hexadecimal code. The table shows several common addresses.

Controller Address Settings					
Address	Upper	Lower	Address	Upper	Lower
Test Mode	0	0	10	0	A
1	0	1	11	0	B
2	0	2	12	0	C
3	0	3	13	0	D
4	0	4	14	0	E
5	0	5	15	0	F
6	0	6	16	1	0
7	0	7	17	1	1
8	0	8	...	...	...
9	0	9	240	F	0

**Note:** Setting both rotary switches to address 0 (set the switches to 0 by rotating them counter clockwise until the arrow points to 0), can activate a test mode. The controller's power must be turned off and then turned back on to run the test mode.

Diagnostic LEDs are located on the controller; the table below shows what each LED denotes:

<b>CPU</b>			
<b>LED</b>	<b>Color</b>	<b>Function</b>	<b>Operation</b>
DS1	Red	CAN TxD	Flashes when controller is transmitting CAN information.
DS2	Red	CAN RxD	Flashes when controller is receiving CAN information.
DS3	Red	System Reset	Off when controller is functioning properly. Flashes at 1.5-second rate if the watchdog timer is not being reset by controller.
DS4	Red	Run	A steady flash indicates the controller is running properly. Normal flash rate is about once per second.
DS5	Red	U15 Programmed	On when U15 contains a valid logic program.
DS7	Red	Link	On when Ethernet interface is in the link-up condition. Flashes when the Ethernet chip detects, transmits, or receives activity.
DS8	Red	Speed	On when the Ethernet interface is at 100Mbps. Off when the Ethernet interface is 10Mbps.
DS9	Red	Duplex	On when the Ethernet interface is at full duplex. Off when the Ethernet interface detects a collision in half-duplex.
DS10	Red	Collision	Flashes when the Ethernet interface detects a collision in half-duplex.
DS12	Red	+2.5V	On when +2.5V power supply is functioning.
DS13	Red	+3.3V	On when +3.3V power supply is functioning.
<b>Product Board</b>			
DS1	Green	+5V	On when +5V power supply is functioning.
DS2	Green	+3.3V	On when +3.3V power supply is functioning.
DS3	Yellow	COM1 TxD	Flashes when transmitting serial information.
DS4	Yellow	COM1 RxD	Flashes when receiving serial information.
<b>Temperature/Light Sensor</b>			
DS1	Green	+5V	On when +5V power supply is functioning.
DS2	Red	Run	A steady flash indicates the controller is running correctly. Normal flash rate is about once a second. Flashes faster when the sensor is transmitting temperature or light information.

## Modem

### Reference Drawings:

Controller Enclosure M2; Modem (0013) ..... **Drawing A-228685**

If a modem was included with the display, it is located inside the display next to the controller board. Refer to **Drawing A-228685** for modem location.

1. To replace a modem, first disconnect the power and signal connections (refer to **Figure 41** for the location of the connectors).
2. The modem is held in place with four screws. Remove the screws with a 3/16" nut driver and lift the modem out of the display the display.

3. Install the new modem, replace the screws, and reconnect power and signal cables.

The modem module has four LEDs.

1. The power LED (DS1) should remain lit while power is applied to the modem.
2. The modem RX (DS3) and TX (DS4) LEDs will flash when communicating.
3. The carrier detect LED (DS5) will light when the modem has established a connection with another modem.

The modem board also has several input and output jacks:

1. J3 is the power input for 12VAC
2. TB2 is a phoenix connector to terminate the Tip and Ring wires
3. J5 is an RJ11 jack for termination of a pre-terminated phone line
4. J6 is the RS232 RJ45 output to the controller
5. J2, TB1, and TB3 are not used in this display application

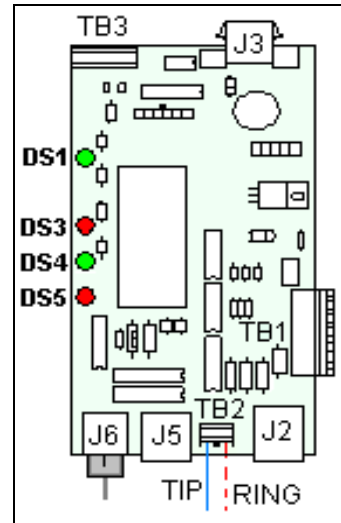

**Figure 41:** Modem Board

A modem system requires the X1 jumper to be set on the controller board. Refer to **Figure 42** for jumper location.

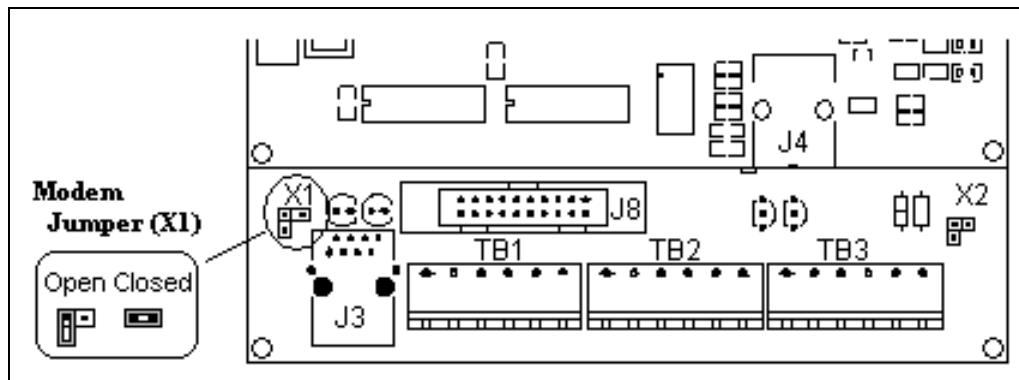

**Figure 42:** Modem Jumper Location

## Fiber Optic Board

### Reference Drawings:

Enclosure Controller M2; Fiber (0013) ..... **Drawing A-228687**

If a fiber optic board was included with the display, it is located inside the display next to the controller board. Refer to **Drawing A-228687** for fiber optic board location.

1. To replace the fiber optic board, first disconnect the power and signal connections (refer to **Figure 43**).
2. The fiber optic board is held in place with four screws. Carefully remove them using a 3/16" nut driver.
3. Install the new fiber optic board, replace the screws and reconnect power and signal cables.

The fiber module has three LEDs.

1. The power LED (DS1) should remain lit while power is applied to the fiber optic board.
2. The receive LED (DS2) will flash when the display fiber optic board is accepting signal from the signal converter.
3. The transmit LED (DS3) will flash when the display fiberboard is sending to the signal converter.

In addition, the fiber optic board has several input and output jacks:

1. J4 and J5 are the two fiber connectors, to which the fiber lines coming from the fiber signal converter connect. (They can also be used for connecting to fiber coming from a fiber optic board in another primary display.)
2. J6 is for the 12VAC power coming from the transformer.
3. J7 is used to transfer RS232 signal via a straight through RJ45 cable from the fiber optic board to the display controller.
4. J2 and J3 could be used as output jacks to a fiber optic board in another primary display.
5. J1 is not used in this application.

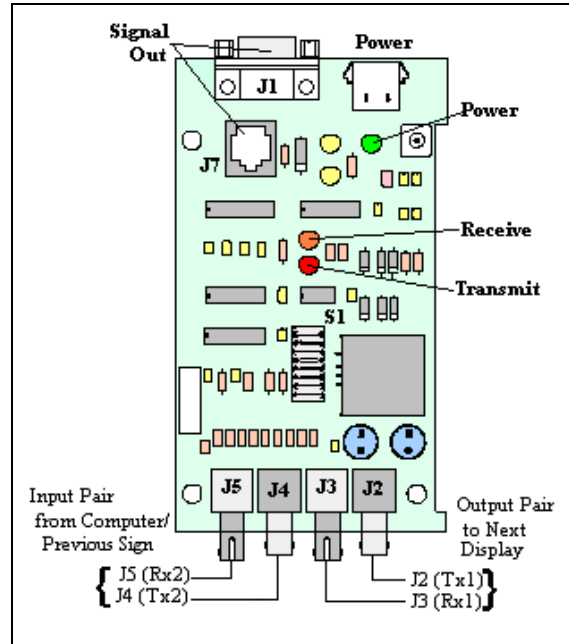

**Figure 43: Fiber Optic Board**

## RS422 Surge Board Assembly

### Reference Drawings:

Enclosure Controller; RS232/RS422 (0013).....**Drawing A-228684**

If a surge board was included with the display, it is located inside the display next to the controller board. Refer to **Drawing A-228684** for surge card location.

1. To replace the surge board, first disconnect the signal connections (refer to **Figure 44**).
2. The surge suppressor is held in place with four screws. Carefully remove them using a 3/16" nutdriver.
3. Install the new surge suppressor, replace the screws, and reconnect the signal cables.

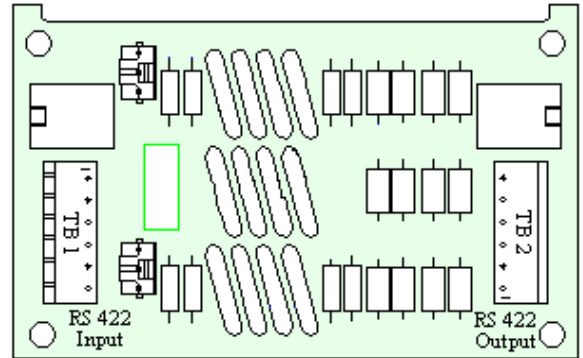

**Figure 44:** RS422 Surge Suppressor

The surge suppressor is an inline device that is used to filter the RS422 data line. It suppresses surges down to a low voltage in order to protect the display controller's RS422 input. The surge suppressor must be firmly connected to the display's chassis in order to be effective. The mounting hardware used to secure the surge suppressor is sufficient if it is fastened properly.

## Ethernet Surge Card

### Reference Drawings:

Enclosure Controller M2; Ethernet (0013) .....**Drawing A-229387**

If an Ethernet surge board was included with the display, it is located inside the display next to the controller board. Refer to **Drawing A-229387** for surge card location.

1. To replace the Ethernet surge board, first disconnect the power and signal connections (refer to **Figure 45**).
2. The Ethernet surge card is held in place with four screws. Carefully remove them using a 3/16" nut driver.
3. Install the new Ethernet surge card, replace the screws and reconnect power and signal cables.

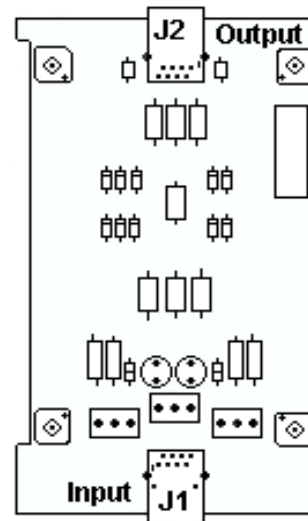

**Figure 45:** Ethernet Surge Card

The surge suppressor is an inline device that is used to filter the RS422 data line. It suppresses surges down to a low voltage in order to protect the display controller's RS422 input. The surge suppressor must be firmly connected to the display's chassis in order to be effective. The mounting hardware used to secure the surge suppressor is sufficient if it is fastened properly.

## Media Converter

If a media converter was included with the display, it is located inside the display next to the controller board.

1. To replace the media converter, first disconnect the power and signal connections (refer to **Figure 46**).
2. The media converter is attached to a plate with four screws. Carefully remove them using a 3/16" nut driver.
3. The media converter is held to the plate by two screws. Release the two screws that hold the media converter to the plate.
4. Install the new media converter, replace the screws, reattach the plate, and reconnect the power and signal cables.



**Figure 46:** Media Converter

The fiber media converter has the following input and output jacks:

1. The fiber transmit and receive jacks are marked by arrows showing their function. They are labeled “10BASE-FL”. The fiber cable from the indoor media converter will connect to these jacks.
2. The input/output Ethernet signal to the display controller is routed through an RJ45 jack, labeled “10BASE-T”.
3. The DC power input from the TB1 on the display controller is connected into the media converter at a jack labeled “9V DC Input”.

## Location of CAN termination jumper

Temperature and light sensors are controlled as part of a CAN network. For the CAN network to work correctly, the network must be terminated at both ends of the network. This is true for a single display, or multiple displays. The correct terminations are completed during the building process. However, if the order or number of displays is changed on-site, the terminating jumper may need to be relocated.

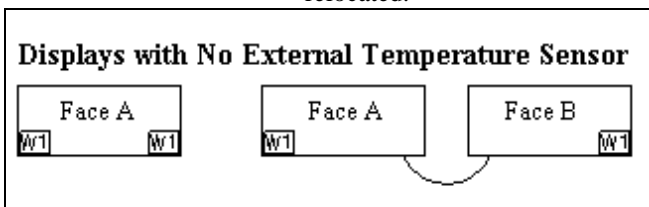

**Figure 47:** Displays with No External Temperature Sensor

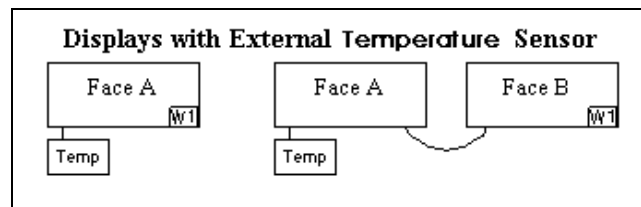
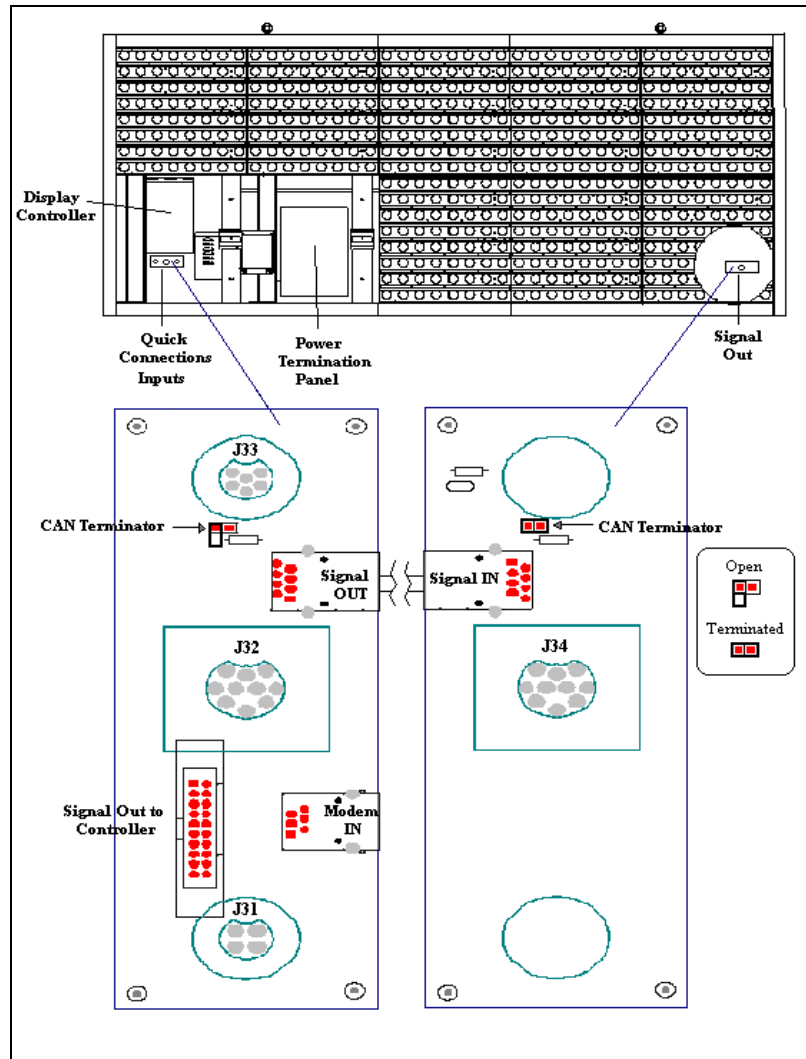

**Figure 48:** Displays with External Temperature Sensor

In the case of those displays that utilize a temperature sensor, the sensor is internally terminated. Therefore, only one other termination needs to be made at the output of the last sign in the network. The most common input location for the temperature sensor is to the first display in the network.



The terminating jumper is located on the quick connect board on the inside of the display. Most displays have both an input and an output quick connect board. When no output board is available, the terminating jumper will be placed on the input board of the last display. Therefore, both boards are shown in **Figure 47** and **Figure 48**.



**Figure 49:** CAN Temperature Sensor Termination Jumper

## Power Supplies

The LED power supplies are identified as assemblies 0A-1259-4402 for amber displays and 0A-1259-4405 for red displays. Each power supply controls two modules.

Complete the following steps to remove a power supply from the sign:

1. Open the module directly in front of the failed power supply.
2. Disconnect all the wires connected to the power supply.
3. Remove the hardware holding the power supply in place to free the unit.
4. Follow these steps in reverse order to install a new power supply.
5. Verify power supply voltage.

## 4.7 Ventilation Systems

Check ventilation fans after 1,500 hours of operation and every 1,500 hours after that to ensure the display cools properly. Check fans more often if the display is located in a dusty or harsh weather environment (i.e. along a gravel road with dust laden air).

- 1,500 hours is equivalent to 83 days if the display operates for 18 hours a day with the power to the display disconnected when not in use.
- 1,500 hours is equivalent to 62 days if the display runs non-stop for 24 hours a day.

**Attention:** Shut off power to the display when it is not in use. Leaving the power on when the display is not operating exposes electrical components to excess condensation, which shortens their life.

Each time you open the display, for whatever reason, take a minute to inspect the fans:

- Check the fan blades for dirt and debris. If the fan blades have a large accumulation of dirt and debris, change the filters more often. Keep the fan blades clean to maintain fan efficiency and ensure proper cooling.
- Spin the fan blades with a pen or pencil to ensure that the bearings are free and the fan is still in balance.

To check the operation of the fans:

- Hold your hand or a piece of light paper beneath the fan to detect air movement. If the operation of a fan is questionable, a fan-test should be performed
- Press button on the internal thermostat and ensure they run freely.
- If the fan does not turn or does not operate smoothly, replace it.

## 4.8 Thermostats

**Reference Drawing:**

Component Layout, AF-3190-\*\*X\*\*\*-89mm..... **Drawing B-181666**

A thermostat controls when the ventilation fans operate in the display. Refer to **Drawing B-181666** for the location of the thermostat. The ventilation fans turn on when the inside of the fan reaches 85° F (29° C), and turn off at 70° F (21° C).

## 4.9 Sign Maintenance

Perform a yearly inspection to maintain safe and dependable display operation. This inspection should address the following issues:

- **Loose Hardware**  
Verify fasteners, such as bolts and rivets, have not come loose. Check, tighten, and replace fasteners as required.
- **Excessive Dust Buildup**  
Occasionally it may be necessary to vacuum the inside of the display cabinet to remove dust/dirt buildup that may interfere with airflow.

- **Water Intrusion – Water Stain Marks**  
Water can enter the display where weather stripping has come loose or deteriorated or where fasteners have come loose allowing gaps in the panels or where moisture may be entering around hardware. Check electronic components for signs of corrosion.
- **Corrosion**  
Check the paint; look for possible corrosion, especially at footings, structural tie points and ground rods.

If you notice any of the above conditions, take action to correct the situation.

## 4.10 Weather Stripping

To ensure the display is weather resistant, Daktronics provides weather stripping around the entire display and around each module. The weather stripping must be properly installed at all times or water may leak into the display, damaging the components.

## 4.11 Troubleshooting

This sub-section contains some symptoms that you may encounter in the displays. This list does not include every possible symptom, but does represent common situations that may occur.

Symptom/Condition	Possible Cause/Remedy
One or more LEDs on a single module fail to light.	<ul style="list-style-type: none"> <li>• Replace/check cables on the module.</li> <li>• Replace pixel strip</li> <li>• Replace the driver.</li> </ul>
One or more LEDs on a single module fail to turn off.	<ul style="list-style-type: none"> <li>• Replace/check cables on module.</li> <li>• Replace pixel strip</li> <li>• Replace the driver.</li> </ul>
A section of the sign is not working. The section extends all the way to the right side of the sign.	<ul style="list-style-type: none"> <li>• Replace/check the ribbon cables.</li> <li>• Check power to the modules.</li> <li>• Replace the first driver on the left side of the first module that is not working.</li> <li>• Replace the second driver that is not working.</li> <li>• Replace the power supply assembly to the first module that is not working.</li> </ul>
One row of modules does not work or is garbled.	<ul style="list-style-type: none"> <li>• Replace/check the ribbon cables.</li> <li>• Replace first driver.</li> <li>• Replace controller.</li> <li>• Check the fuses in the power termination box.</li> </ul>
A group of modules, which share the same power supply assembly, fail to work.	<ul style="list-style-type: none"> <li>• Check power supply voltage.</li> <li>• Check the power supply cables.</li> <li>• Replace the power supply assembly.</li> </ul>

Entire sign fails to work.	<ul style="list-style-type: none"> <li>• Check for proper line voltage into the power termination panel.</li> <li>• Check the fuse in the power termination panel.</li> <li>• Check/replace the ribbon cable from the controller to the driver.</li> <li>• Check the voltage settings on the power supplies.</li> <li>• Verify proper use of the software in the operation manual.</li> <li>• Replace the controller.</li> <li>• (For direct displays) Check the signal cable to the display by doing a loopback test.</li> </ul>
Temperature always reads –196 degrees	<ul style="list-style-type: none"> <li>• Check temperature sensor connections.</li> <li>• Replace the temperature sensor.</li> <li>• Replace the controller.</li> </ul>
Sign is stuck on bright or dim.	<ul style="list-style-type: none"> <li>• Check Manual/Auto dimming in Venus 1500 software.</li> <li>• Check light detector cable.</li> <li>• Check light detector for obstructions.</li> <li>• Replace the light detector.</li> <li>• Replace the controller.</li> </ul>

## 4.12 Initial Operation Information

Every time the display is operated, the display will run through an initialization in which it will display the following:

1. Product Name (Galaxy®)
2. Display Size (Row x Column)
3. Shading (64 Mono)
4. Bootloader Version (OS X.XX)
5. Firmware Number (**ED13305**)
6. Firmware Revision (Rev X.XX)
7. Hardware Address (HW:XX)
8. Software Address (SW:XX)
9. IP Address: ((default) 172.16.192.25)
10. Subnet Msk: ((default) Msk: 255.255.0.0)
11. COM1 Configuration (C1:V15) ((Modem C1:V15) If a Modem is present)
12. COM 2 Configuration (C2:RTD)
13. Socket 3001: (IP 3001: V15)
14. Socket 3002: (IP 3002: RTD)
15. Line Frequency (CLK: AUTO 60 Hz)
16. Display Name Description (Galaxy Row x Column)

After this sequence is complete, the display will blank. A single pixel will flash in the lower right hand corner of the display to show that the display has power, but no messages are currently running.

## 4.13 Replacement Parts List

The following table contains some of the items in this sign that you may need to replace over time. Many of the parts within the sign also list their part numbers on labels affixed to them.

To prevent theft, Daktronics recommends purchasing a lockable cabinet to store manuals and replacement/spare parts.

<b>Part Description</b>	<b>Part Number</b>
Controller	0A-1229-0009
Signal Converter-wire	0A-1127-0255
Signal Converter-Fiber	0A-1127-0256
Serial Cable; RS232 DB9F to DB25M, 6'	W-1249
Modem in display	0P-1279-0003
Light Detector	0P-1247-0003
Digital Temp Sensor	0P-1247-0008
Fiber Board in Display	0P-1127-0024
Surge Suppression Board, RS422	0P-1146-0031
Ethernet Surge Board	0P-1229-2012
Media Converter	A-1778
Radio Client	0A-1146-0078
Radio Server (Outdoor)	0A-1146-0079
Cable; 18" RJ45; 8-Cond.; Straight	0A-1229-0054
Cable; 20 position, 18", dual row	W-1387
Ribbon Assy, 20 Position, 60"	0A-1000-0021
Cable; 20 position, 84", dual row	0A-1000-0023
Cable Assy, 6-pin to 6-pin harness	0A-1261-0001
Cable; 10-pin male to 10-pin male, 4', QC	W-1483
Cable; 10-pin male to 10-pin male, 10', QC	W-1500
20ft, RJ45; 4-pair Twisted	W-1406
30ft, RJ45; 4-pair Twisted	W-1446
50ft, RJ45; 4-pair Twisted	W-1464
Phone Surge Suppressor	A-1527
Quick Connect Interface, Input	0P-1229-2001
Quick Connect Interface, Output	0P-1229-2002
Thermostat Enclosure	0A-1213-4024
<b>Pixel Boards prior to Feb 1, 2003</b>	
Amber Pixel Board, 4x1, 20A	0P-1261-0003
Red Pixel Board, 4x1, 8R	0P-1261-0004
<b>Pixel Boards after Feb 1, 2003</b>	
Amber Pixel Board, 4x1, 20A	0P-1261-0009
Red Pixel Board, 4x1, 8R	0P-1261-0010
Module Driver Board	0P-1261-0008
Power Supply, w/harn.; calibrated, (A-1555), R	0A-1259-4405
Power Supply, w/harn.; calibrated, (A-1593), A	0A-1259-4402
Fan; 134CFM, 120VAC, 22W, 60Hz, 4.5"	B-1053
Line Filter Assembly	0A-1259-4003
Manual; Venus 1500 Operator's	<b>ED13530</b>
Manual; Venus 1500 Radio	<b>ED13932</b>

## 4.14 Daktronics Exchange and Repair and Return Programs

To serve customers' repair and maintenance needs, Daktronics offers both an Exchange Program and a Repair and Return Program.

Daktronics' unique Exchange Program is a quick, economical service for replacing key components in need of repair. If a component fails, Daktronics sends the customer a replacement, and the customer, in turn, sends the failed component to Daktronics. This not only saves money but also decreases display downtime.

Daktronics provides these plans to ensure users get the most from their Daktronics products, and it offers the service to qualified customers who follow the program guidelines explained below. Please call the Help Desk – 877-605-1113 – if you have questions regarding the Exchange Program or any other Daktronics service.

When you call the Help Desk, a trained service technician will work with you to solve the equipment problem. You will work together to diagnose the problem and determine which replacement part to ship. If, after you make the exchange, the equipment still causes problems, please contact our Help Desk immediately.

If the replacement part fixes the problem, package the defective part in the same box and wrapping in which the replacement part arrived, fill out and attach the enclosed UPS shipping document, and **return the part to Daktronics**. In most circumstances, you will be invoiced for the replacement part at the time it is shipped. This bill, which represents the exchange price, is due when you receive it.

Daktronics expects immediate return of an exchange part if it does not solve the problem. The company also reserves the right to refuse equipment that has been damaged due to acts of nature or causes other than normal wear and tear.

If you do not ship the defective equipment Daktronics within 30 working days from the invoice date, Daktronics assumes you are purchasing the replacement part outright (with no exchange), and you will be invoiced for it. This second invoice represents the difference between the exchange price and the full purchase price of the equipment. The balance is due when you receive the second invoice.

If you return the exchange equipment after 30 working days from the invoice date, you will be credited for the amount on the second invoice, minus a restocking fee.

**To avoid a restocking charge, you must return the defective equipment within 30 days from the invoice date.**

Daktronics also offers a Repair and Return Program for items not subject to exchange.

**Return Materials Authorization:** To return parts for service, contact your local representative prior to shipment to acquire a Return Material Authorization (RMA) number. If you do not have a local representative, call the Daktronics Help Desk for the RMA. This expedites repair of your component when it arrives at Daktronics.

**Packaging for Return:** Package and pad the item well so that it will not be damaged in shipment. Electronic components such as printed circuit boards should be installed in an enclosure or placed in an antistatic bag before boxing. Please enclose your name, address, phone number and a clear description of symptoms.

***This is how to reach us:***

***Mail:*** Customer Service, Daktronics Inc.  
PO Box 5128  
331 32nd Ave  
Brookings SD 57006

***Phone:*** Daktronics Help Desk: 877-605-1113 (toll free)  
or 605-697-4034

***Fax:*** 605-697-4444

***E-mail:*** [helpdesk@daktronics.com](mailto:helpdesk@daktronics.com)





## Appendix A: Reference Drawings

---

Refer to **Section 1.1** for information on reading drawing numbers. This appendix lists the following drawings in numerical order by size (A, B, etc.)

Schematic; Power Supply Configurations .....	Drawing A-158225
Z Filter Assy, 2 W/Grnd Bar.....	Drawing A-158472
Assembly, Grounding and Fan Harness .....	Drawing A-161307
Fan Assembly Detail.....	Drawing A-164433
System Riser Diagram, RS422.....	Drawing A-174135
System Riser Diagram, RS232.....	Drawing A-174341
System Riser Diagram, Modem.....	Drawing A-174342
System Riser Diagram, Fiber .....	Drawing A-174344
Assy, Grounding and Fan Harness .....	Drawing A-175194
Layout, Pnl Bd, 8-48x32-112, 89mm, 1 Phase.....	Drawing A-175209
Layout, Pnl Bd, 8-48x32-112, 89mm 3 Phase.....	Drawing A-175212
Schematic, AF-3190-8-48x32x***-89, Mono .....	Drawing A-177829
Enclosure Controller M2; RS422 Echo.....	Drawing A-177921
Power Specs, AF-3190, Amber LEDs .....	Drawing A-178168
Driver Assy; AF-3190-8x8-89mm-Mono.....	Drawing A-178210
Power Specs AF-3190, Red LEDs .....	Drawing A-178240
System Riser Diagram, QC Outdoor Radio, Gen 2.....	Drawing A-185359
Enclosure Controller M2; RS232/422 (0013) .....	Drawing A-228684
Enclosure Controller M2; Modem (0013) .....	Drawing A-228685
Enclosure Controller M2; Fiber (0013) .....	Drawing A-228687
Enclosure Controller M2; Ethernet Wire.....	Drawing A-229387
Block Diagram, Power, AF-3190, 89mm .....	Drawing B-175203
Schem, Sig Wiring, Internal, W/Quick Connect PCB .....	Drawing B-177662
Cntrlr; Galaxy, 8 Conn, J1087 .....	Drawing B-177838
Module Panel, AF-3190-8x8-89mm-A.....	Drawing B-178218
Module Panel, AF-3190-8x8-89mm-R.....	Drawing B-178220
Shop Drawing, AF-3190-8x**-89mm .....	Drawing B-178583
Shop Drawing, AF-3190-16x***-89mm.....	Drawing B-178584
Shop Drawing, AF-3190-24x***-89mm.....	Drawing B-178585
Shop Drawing, AF-3190-32x***-89mm.....	Drawing B-178586
Shop Drawing, AF-3190-40x***-89mm.....	Drawing B-178587
Shop Drawing, AF-3190-48x***-89mm.....	Drawing B-178588
Component Layout, AF-3190-**x**-89mm .....	Drawing B-181666

14.7VDC VERSION (AMBER)  
 0A-1259-4005  
 0A-1259-4402  
 (SET POWER SUPPLIES TO 14.7VDC)

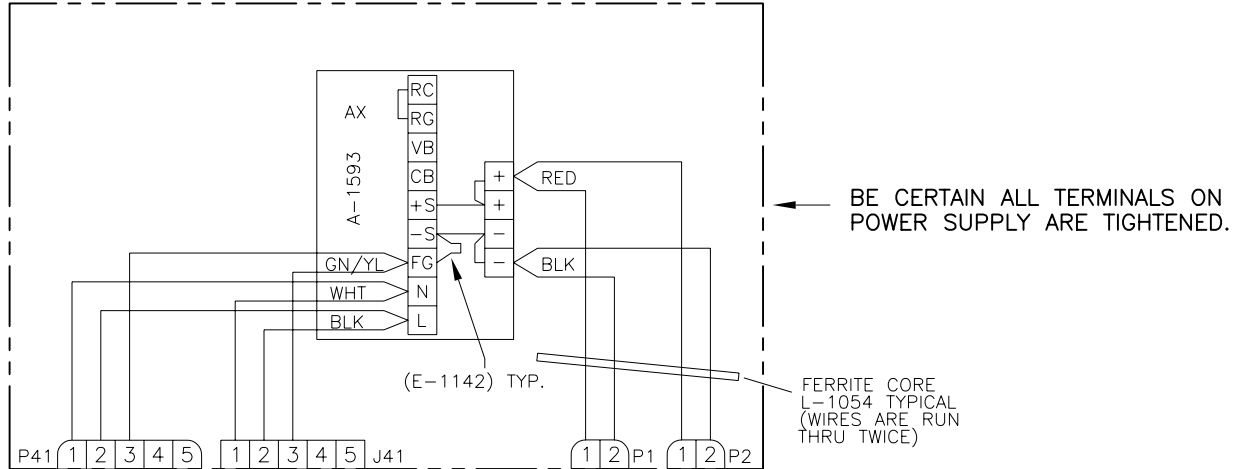

12.0VDC VERSION (RED)  
 0A-1259-4008  
 0A-1259-4405  
 (SET POWER SUPPLIES TO 12.0VDC)

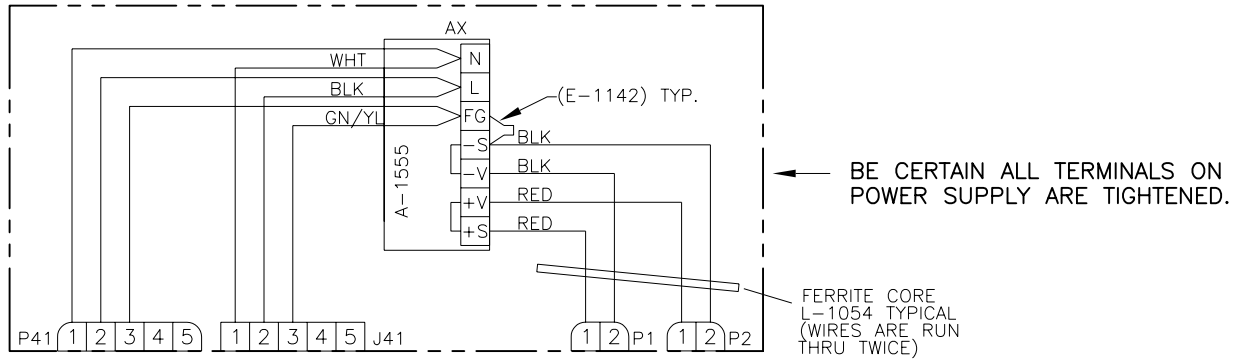

NOTES

- 1) ALL WIRE IS 14 AWG EXCEPT \* IS 18 AWG UNLESS OTHERWISE NOTED.
- 2) REFER TO ASSEMBLY PACKET FOR WIRE ROUTING COMING OFF OF POWER SUPPLIES.

REV.	DATE	DESCRIPTION	BY	APPR.
05	21NOV07	REARRANGED RED AND BLK WIRES ON A-1555 ASSEMBLY PER ECO 59151.	LLK	LLK
04	10FEB05	ADDED L-1054 TO BOTH POWER SUPPLIES.	WRS	LLK
03	05MAR03	ADDED 0A-1259-4402 AND 0A-1259-4405.	LLK	
02	29JAN02	ADDED 0A-1259-4005 AND 0A-1259-4008. REMOVED 0Z-9837-3300PA. (ADDED IT TO DWG B-158483)	LLK	
01	20NOV01	CHANGED PS SETTING FROM 14V TO 14.7V	LLK	LLK

THE CONCEPTS EXPRESSED AND DETAILS SHOWN ON THIS DRAWING ARE CONFIDENTIAL AND PROPRIETARY. DO NOT REPRODUCE BY ANY MEANS, INCLUDING ELECTRONICALLY WITHOUT THE EXPRESSED WRITTEN CONSENT OF DAKTRONICS, INC. COPYRIGHT 2005 DAKTRONICS, INC.	
DAKTRONICS, INC. BROOKINGS, SD 57006	
PROJ:	
TITLE: SCHEMATIC; POWER SUPPLY CONFIGURATIONS	
DES. BY:	DRAWN BY: LKERR DATE: 31OCT01
REVISION	APPR. BY:
05	SCALE:
1259-R03A-158225	

REV.	02	05 FEB 01	ADDED LABELS AND GROUND HARNESS @2.	JAA	JMT
	01	21 DEC 01	REVISED LAYOUT FOR COVER.	JAA	JMT
DATE			DESCRIPTION	BY	APPR.

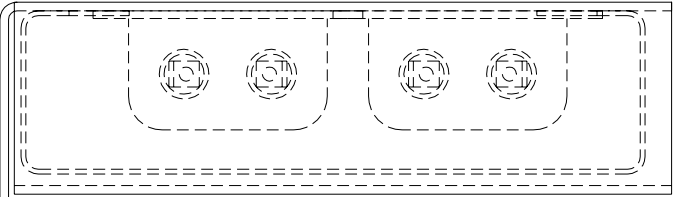

TOP VIEW

NOTES:

ORIENTATION OF LINE FILTERS IS CRITICAL.

OM-158471  
@1

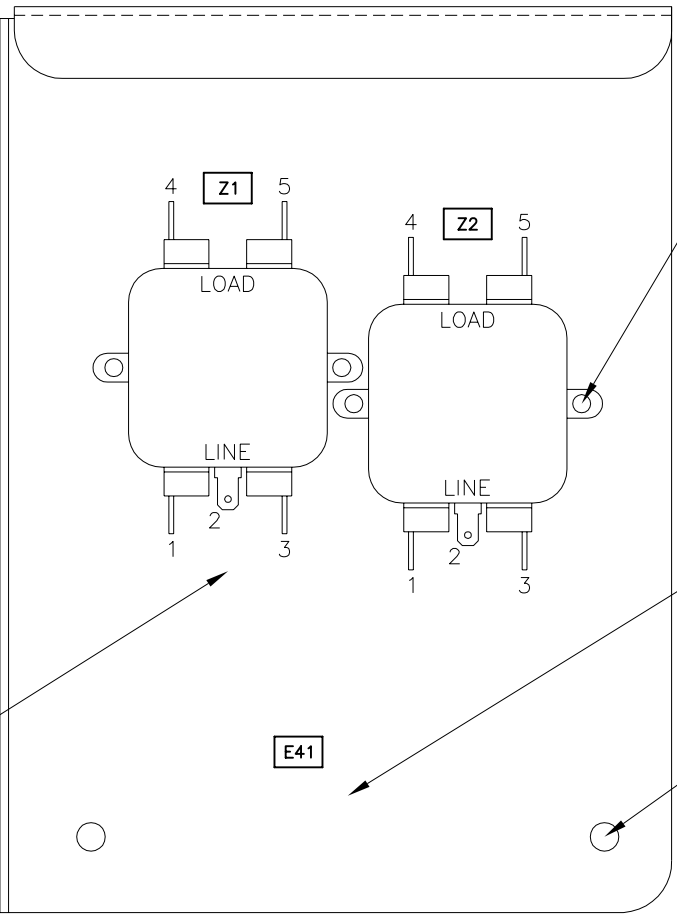

FRONT VIEW

COVER REMOVED FOR CLARITY.

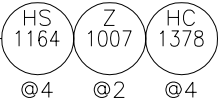

OM-160497  
@1

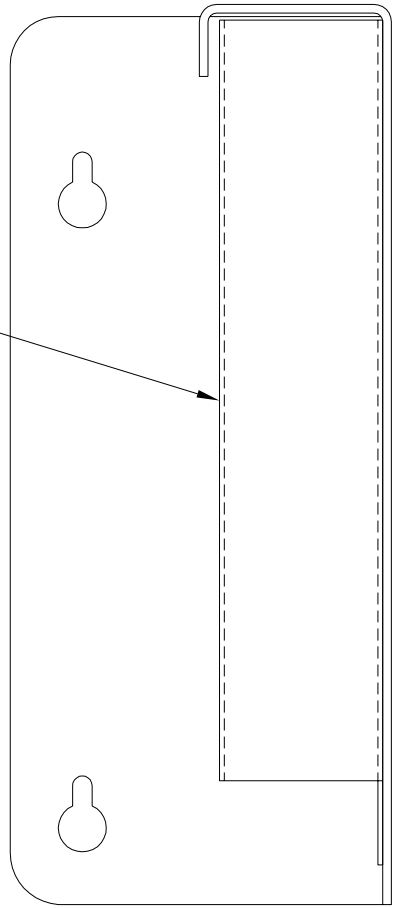
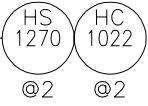
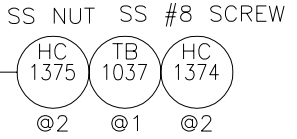

RIGHT SIDE



PROJ: AF-3090 GALAXY LARGE CHARACTER		DAKTRONICS, INC. BROOKINGS, SD 57006	
TITLE: Z-FILTER ASSY 2, W/GND BAR		DRAWN BY: JAMUNDS	
DES. BY: JTELLIN		DATE: 06 NOV 01	
REVISION	APPR. BY:	1259-E07A-158472	
SCALE: 1=2			

REV.	DATE	DESCRIPTION	BY	APPR.
PROJ.: <b>DAKTRONICS, INC. BROOKINGS, SD 57006</b> TITLE: <b>ASSY., GROUNDING &amp; FAN HARNESS</b> DES. BY: <b>LKERR</b> DRAWN BY: <b>LKERR</b> DATE: <b>14JAN02</b> REVISION: <b>APPR. BY:</b> <b>SCALE: NONE</b> <b>1259-R06A-161307</b>				

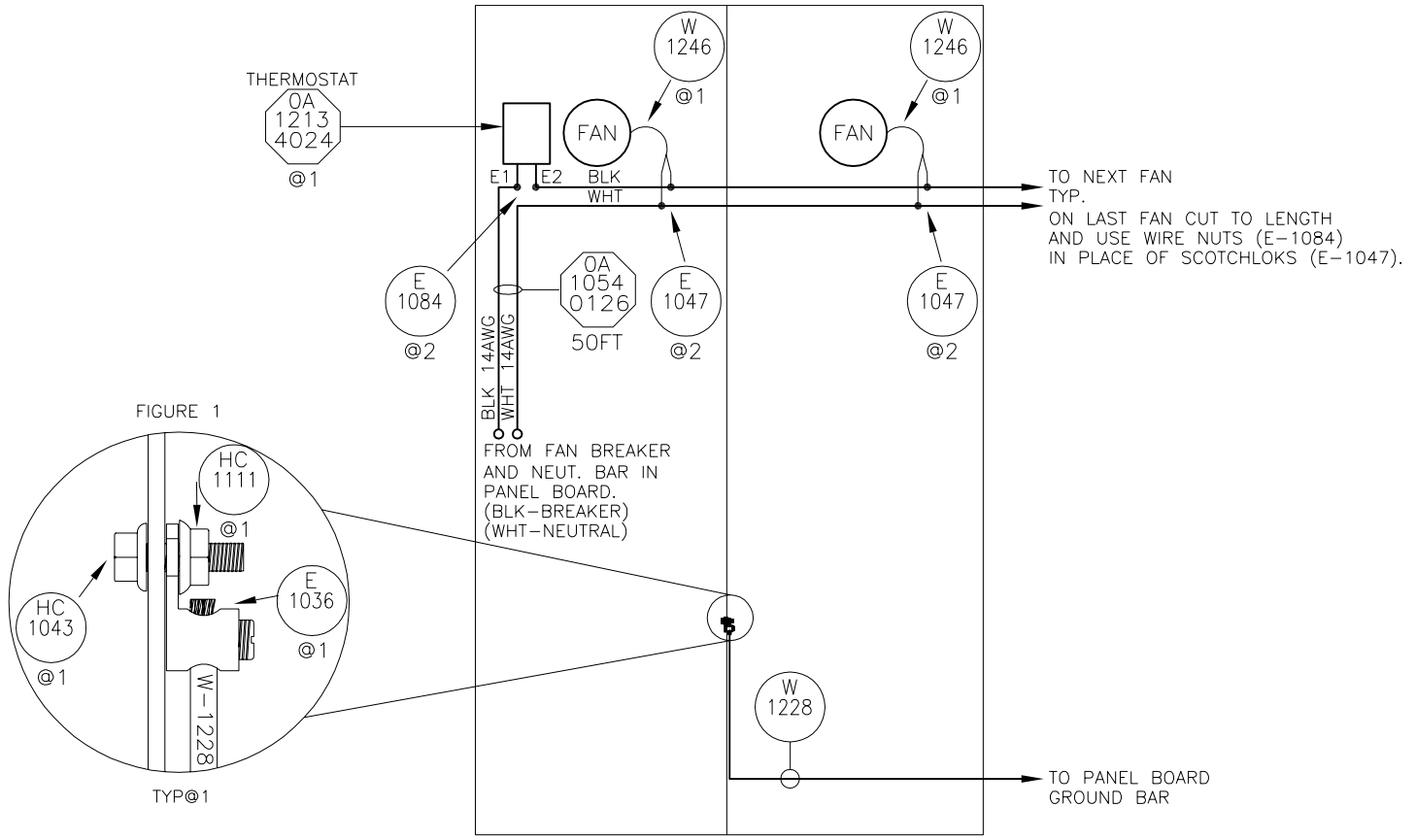

- NOTES:
- OA-1054-0126 WILL BE RUN ALONG THE POWER CONDUIT CLOSEST TO THE FANS.
  - REMOVE ALL PAINT AND ATTACH E-1036 TO THE NEAREST ALIGNMENT CHANNEL.
  - FANS HAVE NO POLARITY.

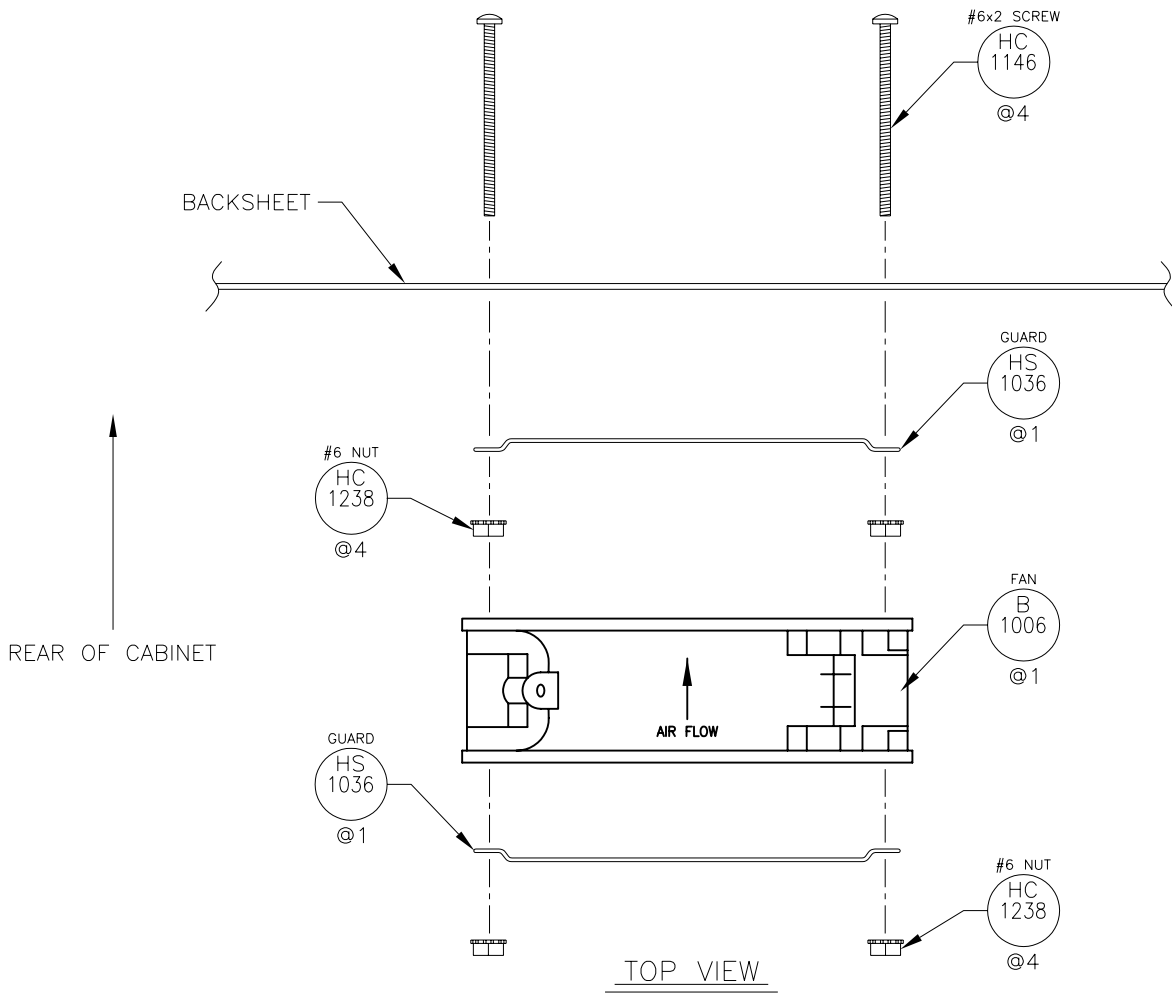

NOTES:

1. FAN PLUG MUST BE ON THE TOP SIDE.
2. AIR FLOW MUST BE OUT OF CABINET.

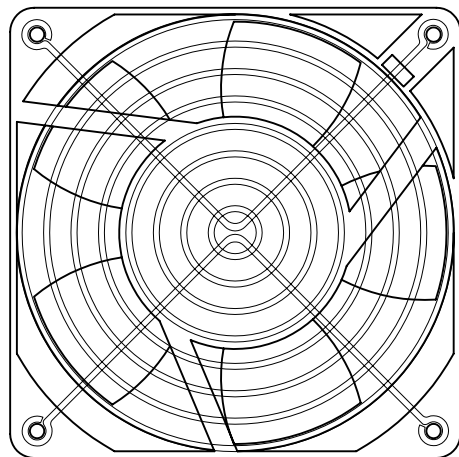

DAKTRONICS, INC. BROOKINGS, SD 57006	
PROJ: AF-3090 GALAXY LARGE CHARACTER	
TITLE: FAN ASSY DETAIL	
DES. BY: JTELLIN	DRAWN BY: JAMUNDS
DATE: 17 APR 02	
REVISION	APPR. BY:
	SCALE: 1 = 2
1259-E10A-164433	

REV.	DATE	DESCRIPTION	BY	APPR.

REV.	DATE	DESCRIPTION	BY	APPR.
01	27JAN03	REMOVED CHART 1 (PWR. SIGNAL SPEC) REPLACED CHART 1 (PWR. SIGNAL SPEC) ADDED TO TERM. PLUG NOTE.	DJM	
02	26DEC03	CHANGED TEMP SENSOR PART NUMBER FROM 0A-1241-4017 TO 0A-1151-0005. REMOVED NOTE.	DJM	
03	26 MAR 04	REPLACED 0A-1127-0237 WITH 0A-1127-0255 (INCLUDES SURGE PROTECTION)	SAI	DJM

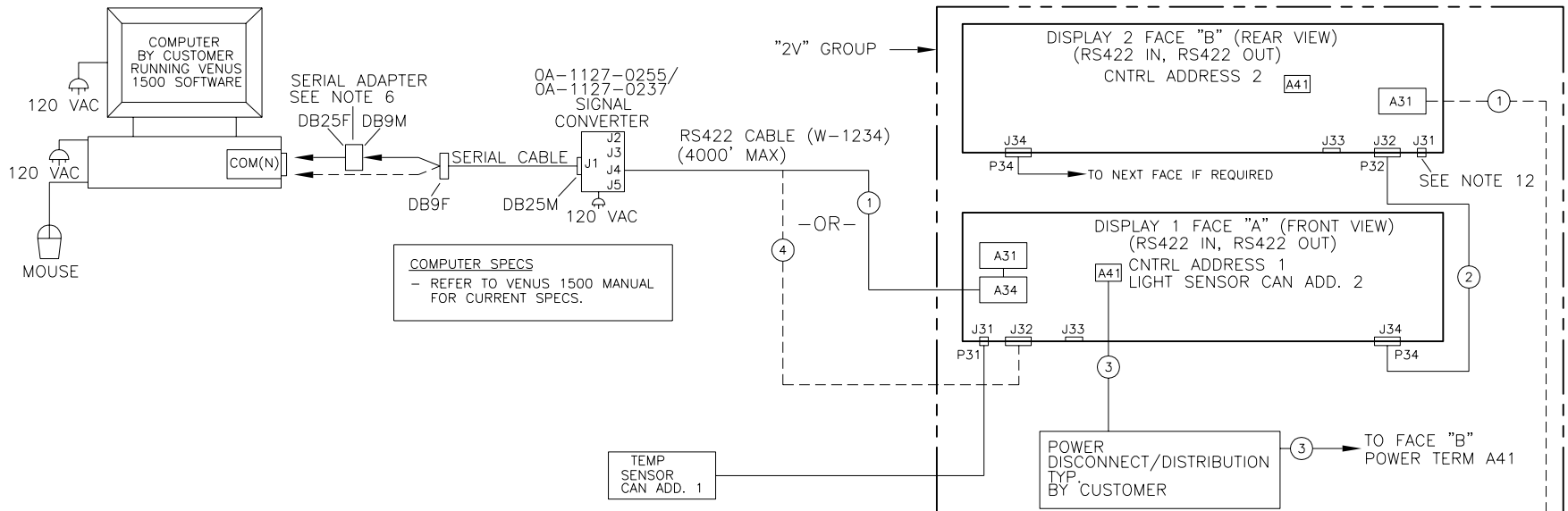

NOTES

- 4 CONDUCTOR, 22 AWG, STRANDED SHIELDED CABLE, DAK. P.N. (W-1234), MANHATTAN P.N. (M4473) OR EQUIV. IN CONDUIT WHERE REQUIRED. FIELD SIGNAL TERMINATIONS TO BE TERMINAL BLOCKS.
- 10 CONDUCTOR, 22 AWG, STRANDED CABLE, DAK. P.N. (W-1483). LENGTH TO BE 4 FT MAX. FIELD SIGNAL TERMINATIONS TO BE 10 POS QUICK CONNECT.
- POWER FEEDER SIZED AS NEEDED BY CUSTOMER
- OPTIONAL RS422 INPUT QUICK CONNECT CABLE.
- RS/422 CONTROL EQUIPMENT KIT INCLUDES:  
W-1249.....SERIAL CABLE  
A-1603.....DB9 TO DB25 ADAPTER  
0A-1127-0255.....SIGNAL CONVERTER  
0A-1146-0005.....NETWORK/CABLE TESTER
- USE EITHER THE DB9 OR DB25, DEPENDING ON YOUR PC'S REQUIREMENTS.
- INPUT TO CONVERTER IS RS232, OUTPUTS RS422.
- ALL SIGNAL CABLES BY CUSTOMER. LABOR TO PULL CABLES BY CUSTOMER.
- ALL POWER WIRES BY CUSTOMER. LABOR TO PULL WIRES BY CUSTOMER.
- ALL WIRING TO MEET NEC AND LOCAL ELECTRICAL CODES.
- DISPLAYS MUST BE GROUNDED PER ARTICLE 250 AND 600 OF THE NATIONAL ELECTRICAL CODE.
- LAST DISPLAY IN A GROUP REQUIRES A CAN TERMINATION RESISTOR(INSTALLED AT FACTORY). REFER TO THE DISPLAY MANUAL FOR CAN TERMINATOR LOCATION.  
\*\*\*BELOW ONLY APPLIES TO AF-3165 (TYPE 1)\*\*\*  
TERMINATOR PLUG (DAK P.N. 0A-1241-4010) MUST BE INSTALLED ON LAST DISPLAY IN EACH GROUP.
- A31= DISPLAY CONTROLLER  
A34= SURGE PROTECTOR, RS422

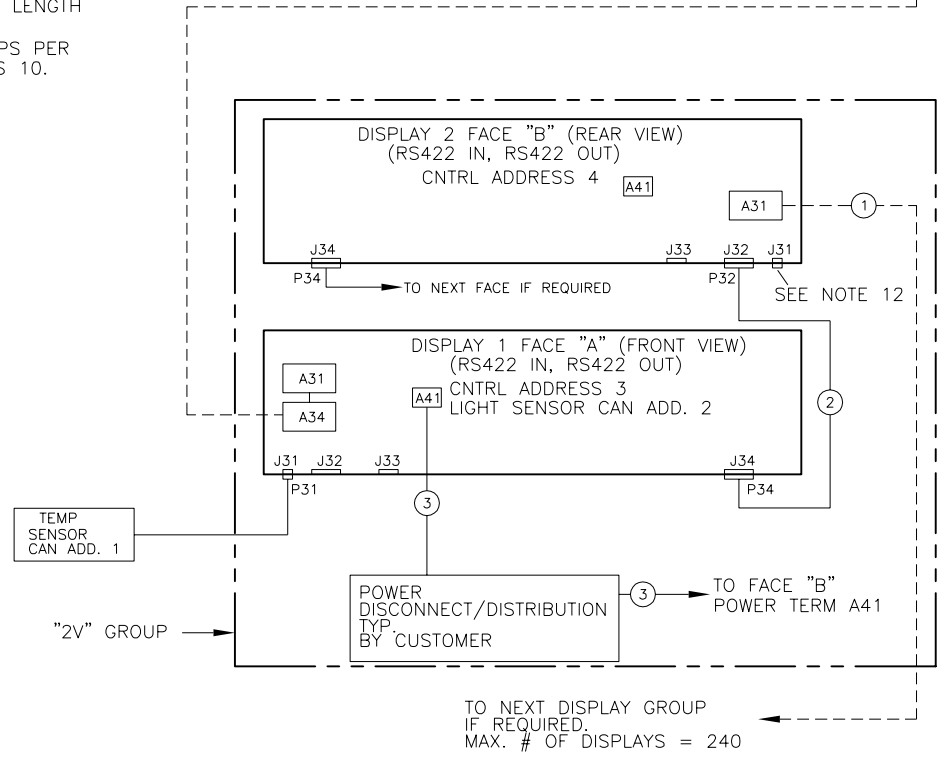

REVISION	APPR. BY:	DATE:
03	LKERR	22AUG02
SCALE:	NONE	
PROJ.: OUTDOOR LED PRODUCT LINE TITLE: SYSTEM RISER DIAGRAM, RS422 DES. BY: LKERR DRAWN BY: LKERR DAKTRONICS, INC. BROOKINGS, SD 57006 THE CONCEPTS EXPRESSED AND DETAILS SHOWN ON THIS DRAWING ARE CONFIDENTIAL AND PROPRIETARY. DO NOT REPRODUCE BY ANY MEANS, INCLUDING ELECTRONICALLY WITHOUT THE EXPRESSED WRITTEN CONSENT OF DAKTRONICS, INC. COPYRIGHT 2002 DAKTRONICS, INC.		
1229-R01A-174135		

REV.	DATE	DESCRIPTION	BY	APPR.
01	27JAN03	REMOVED CHART 1 (PWR. SIGNAL SPEC). REPLACED OA-1241-4016 WITH W-1483. ADDED TO TERM. PLUG NOTE.	DJM	
02	26DEC03	CHANGED TEMP SENSOR PART NUMBER FROM OA-1241-4017 TO OA-1151-0005. REMOVED NOTE 3 AND 6.	DJM	

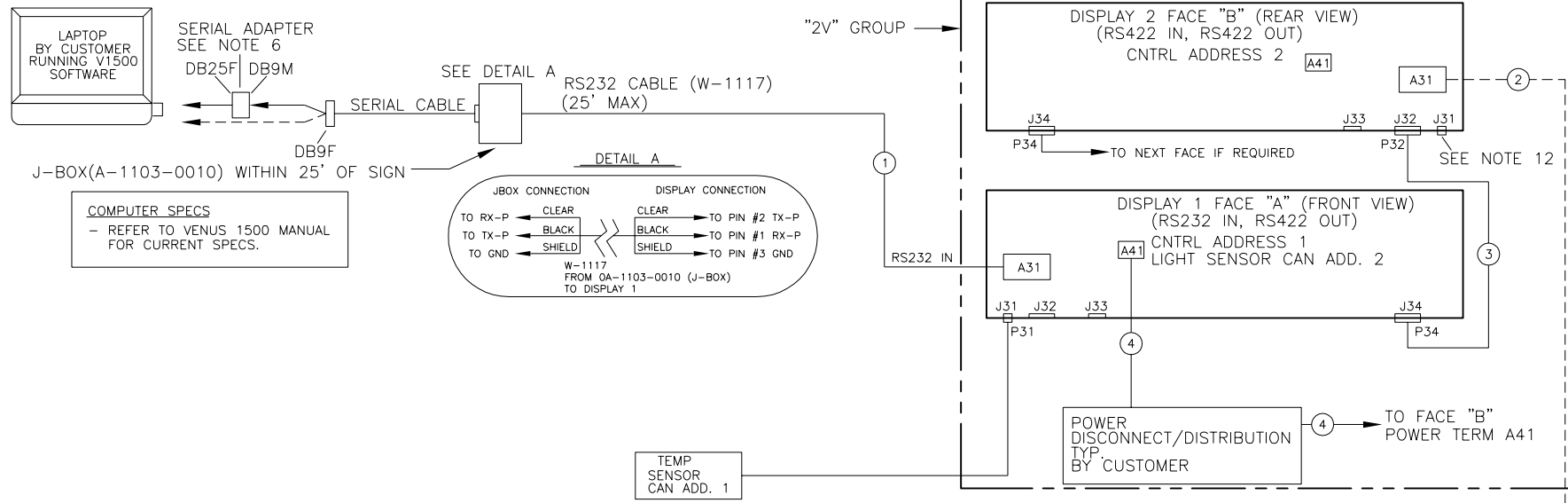

SERIAL ADAPTER  
SEE NOTE 6  
DB25F DB9M

SERIAL CABLE  
SEE DETAIL A  
RS232 CABLE (W-1117)  
(25' MAX)

J-BOX(A-1103-0010) WITHIN 25' OF SIGN

COMPUTER SPECS  
- REFER TO VENUS 1500 MANUAL FOR CURRENT SPECS.

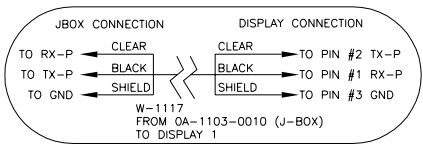

TEMP SENSOR CAN ADD. 1

OA-1151-0005 INCLUDES 25' CABLE  
OPTIONAL CABLE LENGTH 500FT. MAX  
MAX. # OF DROPS PER CAN NETWORK IS 10.

NOTES

- 2 CONDUCTOR, 18 AWG, STRANDED SHIELDED CABLE. DAK. P.N. (W-1117). BELDON P.N. (8760) OR EQUIV.
- 4 CONDUCTOR, 22 AWG, STRANDED SHIELDED CABLE. DAK. P.N. (W-1234). MANHATTAN P.N. (M4473) OR EQUIV. IN CONDUIT WHERE REQUIRED. FIELD SIGNAL TERMINATIONS TO BE TERMINAL BLOCK.
- 10 CONDUCTOR, 18 AWG, STRANDED SHIELDED CABLE. DAK. P.N. (W-1483). LENGTH TO BE 4 FT MAX. FIELD SIGNAL TERMINATIONS TO BE 10 POS QUICK CONNECT.
- POWER FEEDER SIZED AS NEEDED BY CUSTOMER
- RS-232 CONTROL EQUIPMENT KIT INCLUDES:  
W-1249.....SERIAL CABLE  
A-1603.....DB9 TO DB25 ADAPTER  
A-1103-0010.....J-BOX  
A-1146-0005.....NETWORK/CABLE TESTER
- USE EITHER THE DB9 OR DB25, DEPENDING ON YOUR PC'S REQUIREMENTS.
- ALL SIGNAL CABLES BY CUSTOMER. LABOR TO PULL CABLES BY CUSTOMER.
- ALL POWER WIRES BY CUSTOMER. LABOR TO PULL WIRES BY CUSTOMER.
- ALL WIRING TO MEET NEC AND LOCAL ELECTRICAL CODES.
- DISPLAYS MUST BE GROUNDED PER ARTICLE 250 AND 600 OF THE NATIONAL ELECTRICAL CODE.
- LAST DISPLAY IN A GROUP REQUIRES A CAN TERMINATION RESISTOR(INSTALLED AT FACTORY). REFER TO THE DISPLAY MANUAL FOR CAN TERMINATOR LOCATION.  
\*\*\*BELOW ONLY APPLIES TO AF-3165 (TYPE 1)\*\*\*  
TERMINATOR PLUG (DAK P.N. OA-1241-4010) MUST BE INSTALLED ON LAST DISPLAY IN EACH GROUP.
- A31= DISPLAY CONTROLLER
- INPUT TO J-BOX IS RS232, OUTPUT IS RS232.

PROJ:	OUTDOOR LED PRODUCT LINE
TITLE:	SYSTEM RISER DIAGRAM, RS232
DES. BY:	LKERR
APPR. BY:	
DATE:	28AUG02
REVISION	02
SCALE:	NONE
1229-R01A-174341	

THE CONCEPTS EXPRESSED AND DETAILS SHOWN ON THIS DRAWING ARE CONFIDENTIAL AND PROPRIETARY. DO NOT REPRODUCE BY ANY MEANS, INCLUDING ELECTRONICALLY WITHOUT THE EXPRESSED WRITTEN CONSENT OF DAKTRONICS, INC. COPYRIGHT 2002 DAKTRONICS, INC.

DAKTRONICS, INC. BROOKINGS, SD 57006

REV.	DATE	DESCRIPTION	BY	APPR.
02	26DEC03	CHANGED TEMP SENSOR PART NUMBER FROM 0A-1241-4017 TO 0A-1151-0005. REMOVED NOTE 3.	DJM	
01	27JAN03	REMOVED CHART 1 (PWR. SIGNAL SPEC). REPLACED 0A-1241-4016 WITH W-1483. ADDED TO TERM PLUG NOTE.	DJM	

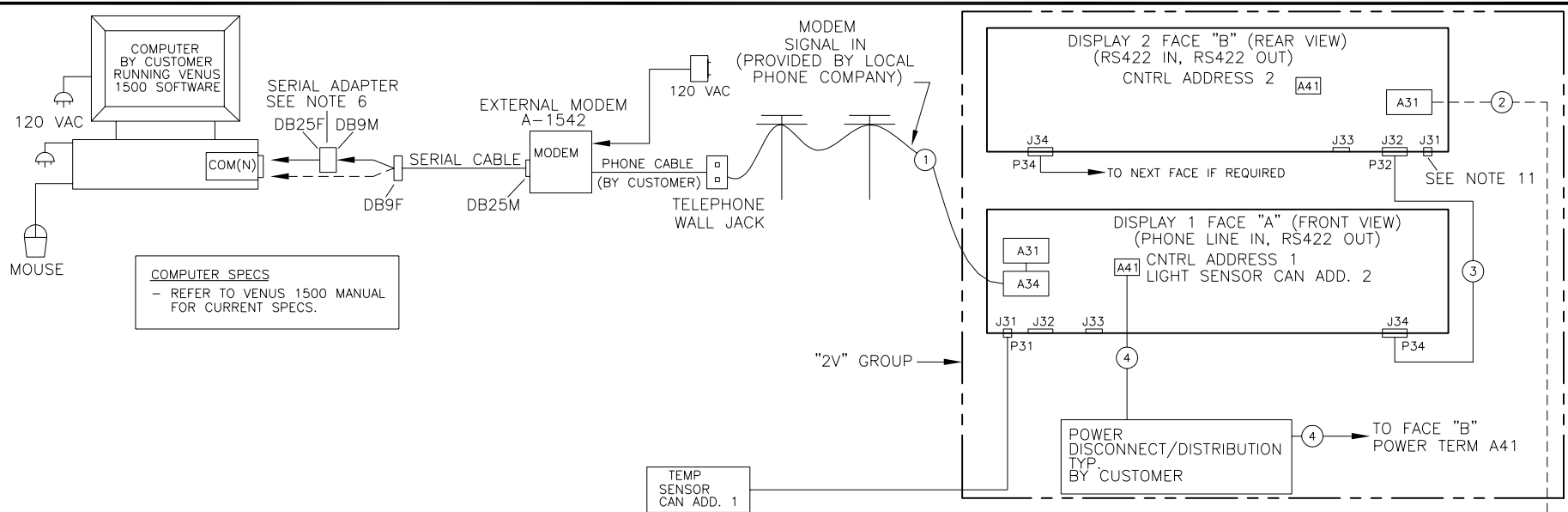

**COMPUTER SPECS**  
 - REFER TO VENUS 1500 MANUAL FOR CURRENT SPECS.

0A-1151-0005  
 INCLUDES 25' CABLE  
 OPTIONAL CABLE LENGTH  
 500FT. MAX  
 MAX. # OF DROPS PER  
 CAN NETWORK IS 10.

**NOTES**

- 1 DEDICATED PHONE CABLE WITH THE "TIP & RING" IDENTIFIED. BY CUSTOMER.
- 2 4 CONDUCTOR, 22 AWG, STRANDED SHIELDED CABLE. DAK. P.N. (W-1234). MANHATTAN P.N. (M4473) OR EQUIV. IN CONDUIT WHERE REQUIRED. FIELD SIGNAL TERMINATIONS TO BE PHOENIX TERMINAL BLOCKS.
- 3 10 CONDUCTOR, 18 AWG, STRANDED SHIELDED CABLE. DAK. P.N. (W-1483). LENGTH TO BE 4 FT MAX. FIELD SIGNAL TERMINATIONS TO BE 10 POS QUICK CONNECT.
- 4 POWER FEEDER SIZED AS NEEDED BY CUSTOMER
5. MODEM CONTROL EQUIPMENT KIT INCLUDES:  
 W-1249.....SERIAL CABLE  
 A-1603.....DB9 TO DB25 ADAPTER  
 A-1542.....EXTERNAL MODEM  
 A-1146-0005.....NETWORK/CABLE TESTER
6. USE EITHER THE DB9 OR DB25, DEPENDING ON YOUR PC'S REQUIREMENTS.
7. ALL SIGNAL CABLES BY CUSTOMER. LABOR TO PULL CABLES BY CUSTOMER.
8. ALL POWER WIRES BY CUSTOMER. LABOR TO PULL WIRES BY CUSTOMER.
9. ALL WIRING TO MEET NEC AND LOCAL ELECTRICAL CODES.
10. DISPLAYS MUST BE GROUNDED PER ARTICLE 250 AND 600 OF THE NATIONAL ELECTRICAL CODE.
11. LAST DISPLAY IN A GROUP REQUIRES A CAN TERMINATION RESISTOR(INSTALLED AT FACTORY). REFER TO THE DISPLAY MANUAL FOR CAN TERMINATOR LOCATION.  
 \*\*\*BELOW ONLY APPLIES TO AF-3165 (TYPE 1)\*\*\*  
 TERMINATOR PLUG (DAK P.N. 0A-1241-4010) MUST BE INSTALLED ON LAST DISPLAY IN EACH GROUP.
12. A31= DISPLAY CONTROLLER  
 A34= DISPLAY MODEM

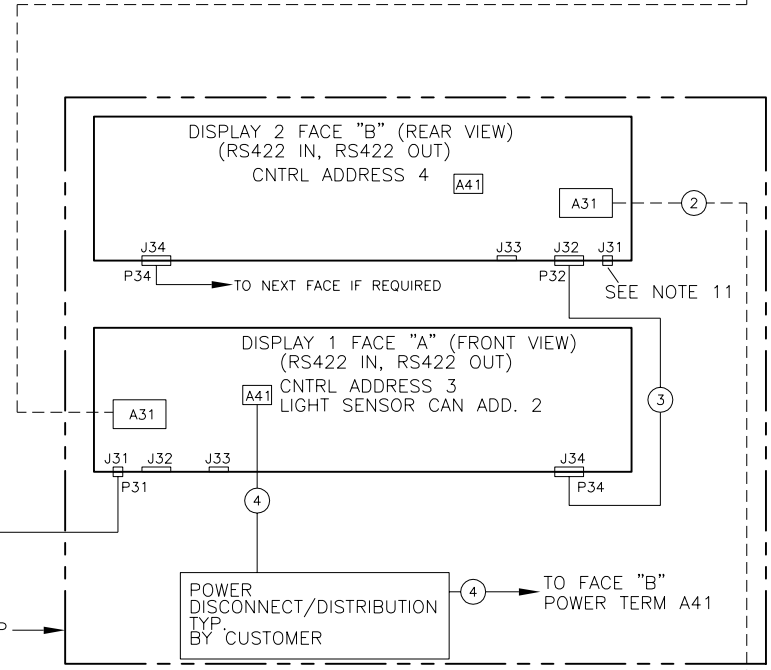

TO NEXT DISPLAY GROUP  
 IF REQUIRED.  
 MAX. # OF DISPLAYS = 240

THE CONCEPTS EXPRESSED AND DETAILS SHOWN ON THIS DRAWING ARE CONFIDENTIAL AND PROPRIETARY. DO NOT REPRODUCE BY ANY MEANS, INCLUDING ELECTRONICALLY WITHOUT THE EXPRESSED WRITTEN CONSENT OF DAKTRONICS, INC. COPYRIGHT 2002 DAKTRONICS, INC.

PROJ: OUTDOOR LED PRODUCT LINE  
 TITLE: SYSTEM RISER DIAGRAM, MODEM  
 DES. BY: LKERR  
 DRAWN BY: LKERR  
 DATE: 28AUG02  
 REVISION 02  
 APRR. BY: NONE  
 SCALE: NONE  
 1229-R01A-174342

DAKTRONICS, INC. BROOKINGS, SD 57006



REV.	DATE	DESCRIPTION	BY	APPR.
01	27JAN03	REMOVED CHART 1 (PWR. SIGNAL SPEC). REPLACED OA-1241-4017 TO OA-1151-0005. ADDED TO TERM PLUG NOTE.	DJM	
02	26DEC03	CHANGED TEMP SENSOR PART NUMBER FROM OA-1241-4017 TO OA-1151-0005. REMOVED NOTE 3.	DJM	
03	26 MAR 04	REPLACED OA-1127-0239 WITH OA-1127-0256 (INCLUDES SURGE PROTECTION)	SAI	DJM

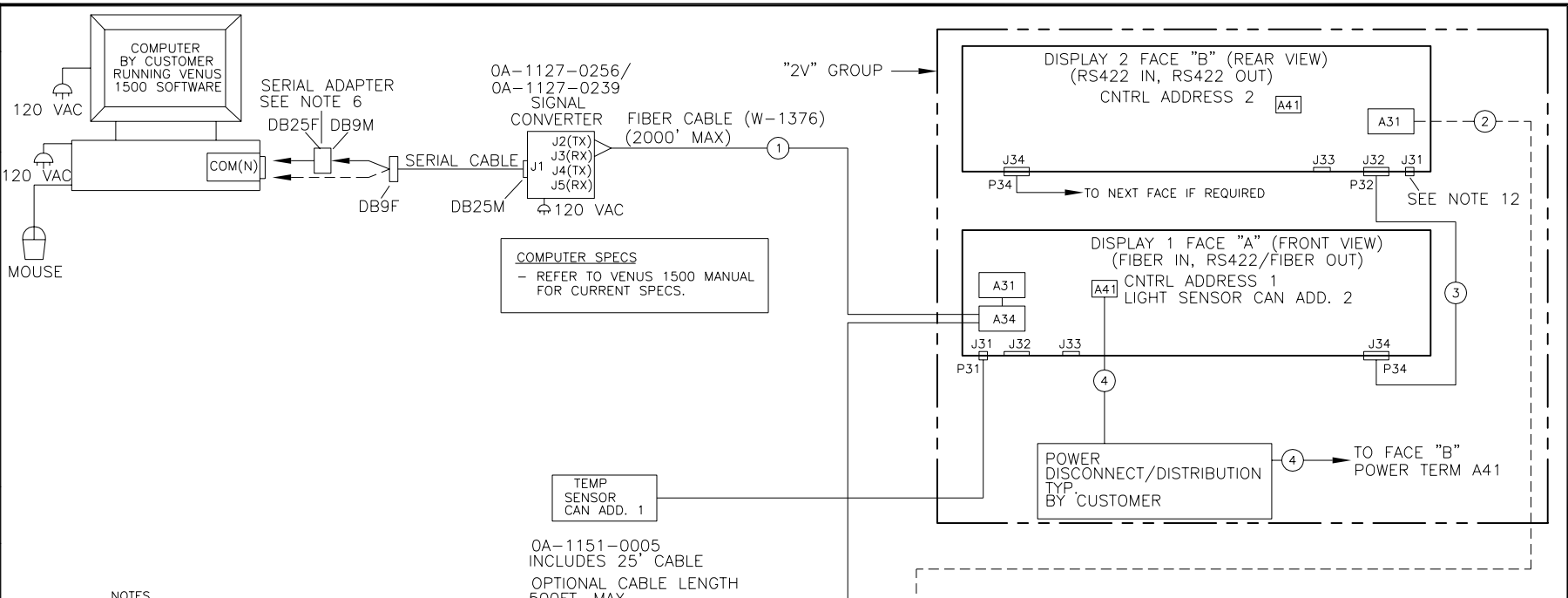

NOTES

- 4 FIBER CABLE, 62.5/125 GRADE DAK. P.N. (W-1376). GRAYBAR P.N. (BX04080D-W3SB1UC900R) IN CONDUIT WHERE REQUIRED.
- 4 CONDUCTOR, 22 AWG, STRANDED SHIELDED CABLE. DAK. P.N. (W-1234). MANHATTAN P.N. (M4473) OR EQUIV. IN CONDUIT WHERE REQUIRED. FIELD SIGNAL TERMINATIONS TO BE TERMINAL BLOCKS.
- 10 CONDUCTOR, 22 AWG, STRANDED CABLE. DAK. P.N. (W-1483). LENGTH TO BE 4 FT MAX. FIELD SIGNAL TERMINATIONS TO BE 10 POS QUICK CONNECT.
- POWER FEEDER SIZED AS NEEDED BY CUSTOMER
- FIBER CONTROL EQUIPMENT KIT INCLUDES:  
W-1249.....SERIAL CABLE  
A-1603.....DB9 TO DB25 ADAPTER  
A-1127-0256.....SIGNAL CONVERTER  
A-1146-0005.....NETWORK/CABLE TESTER
- USE EITHER THE DB9 OR DB25, DEPENDING ON YOUR PC'S REQUIREMENTS.
- INPUT TO CONVERTER IS RS232.
- ALL SIGNAL CABLES BY CUSTOMER. LABOR TO PULL CABLES BY CUSTOMER.
- ALL POWER WIRES BY CUSTOMER. LABOR TO PULL WIRES BY CUSTOMER.
- ALL WIRING TO MEET NEC AND LOCAL ELECTRICAL CODES.
- DISPLAYS MUST BE GROUNDED PER ARTICLE 250 AND 600 OF THE NATIONAL ELECTRICAL CODE.
- LAST DISPLAY IN A GROUP REQUIRES A CAN TERMINATION RESISTOR (INSTALLED AT FACTORY). REFER TO THE DISPLAY MANUAL FOR CAN TERMINATOR LOCATION.  
\*\*\*BELOW ONLY APPLIES TO AF-3165 (TYPE 1)\*\*\*  
TERMINATOR PLUG (DAK P.N. OA-1241-4010) MUST BE INSTALLED ON LAST DISPLAY IN EACH GROUP.
- A31= CONTROLLER ASSEMBLY  
A34= FIBER INTERFACE BOARD

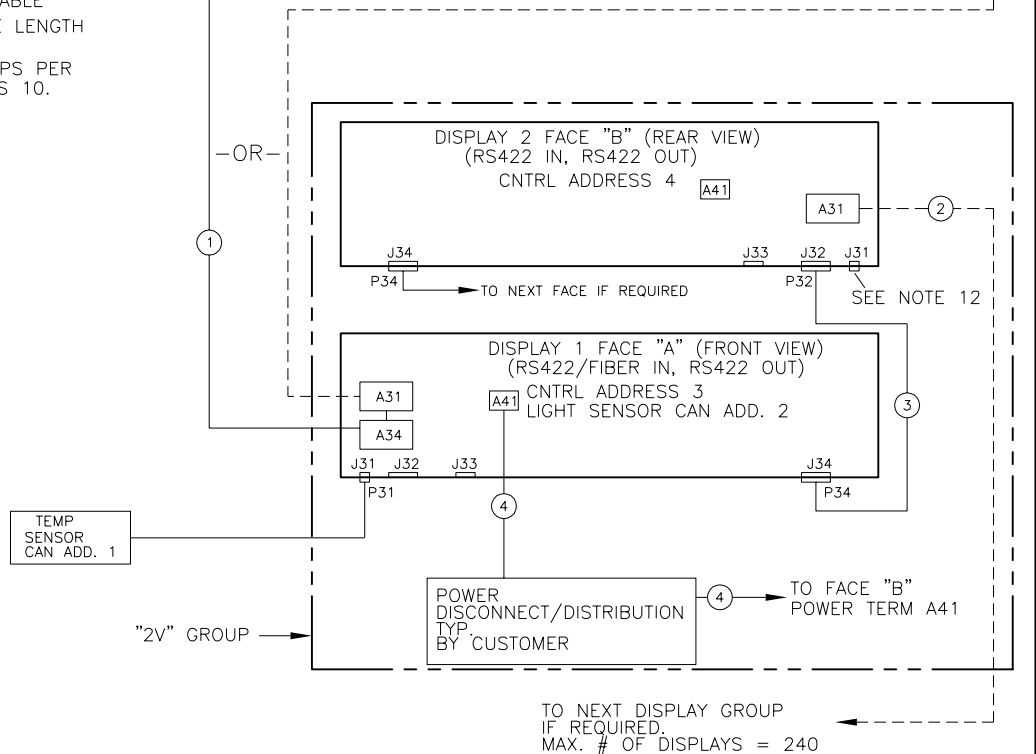

REVISION	APPR. BY:	DATE:
03	LKERR	06SEP02

DAKTRONICS, INC. BROOKINGS, SD 57006

PROJ: OUTDOOR LED PRODUCT LINE

TITLE: SYSTEM RISER DIAGRAM, FIBER

DES. BY: LKERR

SCALE: NONE

1229-R01A-174344

THE CONCEPTS EXPRESSED AND DETAILS SHOWN ON THIS DRAWING ARE CONFIDENTIAL AND PROPRIETARY. DO NOT REPRODUCE BY ANY MEANS, INCLUDING ELECTRONICALLY WITHOUT THE EXPRESSED WRITTEN CONSENT OF DAKTRONICS, INC. COPYRIGHT 2002 DAKTRONICS, INC.

REV.	01	19 AUG 05	CHANGED THERMOSTAT P.N. FROM OA-1213-4024 TO OA-1327-3101. REMOVED LENGTH FROM P.N. TAG, REMOVED LENGTH FROM OA-1051-126.	RBN	LLK
DATE			DESCRIPTION	BY	APPR.

REVISON	01	SCALE: NONE	1259-R06A-175194
DES. BY: LKERR	APPR. BY:	DATE: 16SEP02	

PROJ: GALAXY, LARGE CHARACTER  
 TITLE: ASSY., GROUNDING & FAN HARNESS  
 DAKTRONICS, INC. BROOKINGS, SD 57006  
 THE CONCEPTS EXPRESSED AND DETAILS SHOWN ON THIS DRAWING ARE CONFIDENTIAL AND PROPRIETARY. DO NOT REPRODUCE BY ANY MEANS, INCLUDING ELECTRONICALLY WITHOUT THE EXPRESSED WRITTEN CONSENT OF DAKTRONICS, INC. COPYRIGHT 2002 DAKTRONICS, INC.

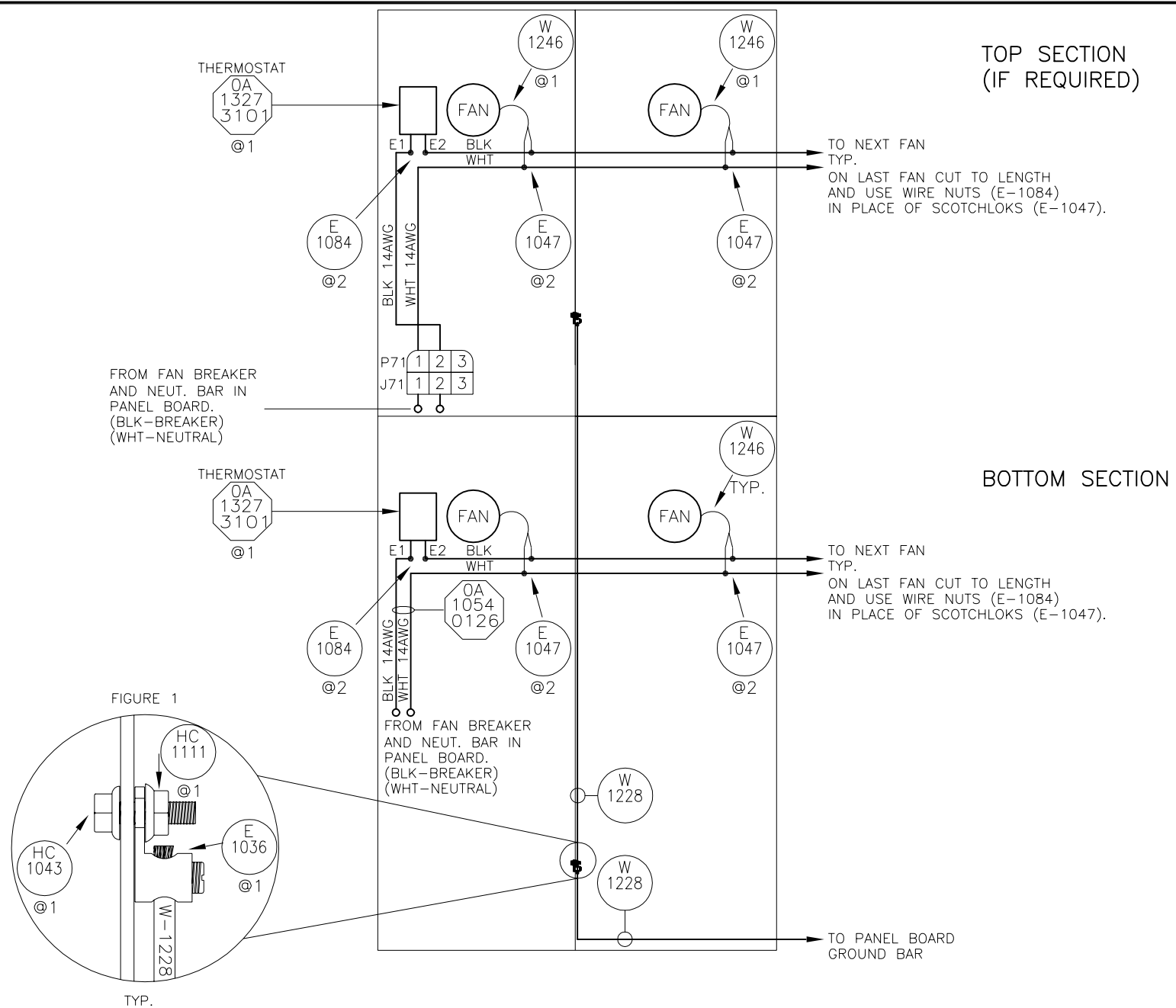

- NOTES:
- OA-1054-0126 WILL BE RUN ALONG THE POWER CONDUIT CLOSEST TO THE FANS.
  - REMOVE ALL PAINT AND ATTACH E-1036 TO THE NEAREST ALIGNMENT CHANNEL.
  - FANS HAVE NO POLARITY.

8X32-112 (OA-1259-4300) EN-1217

PANEL BOARD

	15	15	15				
1	2	3	4	5	6	7	8
NOT USED	Z1 A10X EVEN PS	Z2 A10X ODD PS	CNTRL/FANS				NOT USED

16X48-112 (OA-1259-4301) EN-1217

PANEL BOARD

	15	15	15	15	15		
1	2	3	4	5	6	7	8
NOT USED	Z1 A10X EVEN PS	Z2 A10X ODD PS	Z3 A20X EVEN PS	Z4 A20X ODD PS	CNTRL/FANS		NOT USED

24X48-112 (OA-1259-4302) EN-1043

PANEL BOARD

15A	1	Z1 A10X EVEN PS	Z2 A10X ODD PS	2	15A
15A	3	Z3 A20X EVEN PS	Z4 A20X ODD PS	4	15A
15A	5	Z5 A30X EVEN PS	CNTRL/FANS	6	15A
15A	7	Z6 A30X ODD PS		8	
	9			10	
	11			12	

32X48-112 (OA-1259-4303) EN-1043

PANEL BOARD

15A	1	Z1 A10X EVEN PS	Z2 A10X ODD PS	2	15A
15A	3	Z3 A20X EVEN PS	Z4 A20X ODD PS	4	15A
15A	5	Z5 A30X EVEN PS	Z6 A30X ODD PS	6	15A
15A	7	Z7 A40X EVEN PS	Z8 A40X ODD PS	8	15A
15A	9	FANS	CONTROLLER	10	15A
	11			12	

40X48-112 (OA-1259-4304) EN-1043

PANEL BOARD

15A	1	Z1 A10X EVEN PS	Z2 A10X ODD PS	2	15A
15A	3	Z3 A20X EVEN PS	Z4 A20X ODD PS	4	15A
15A	5	Z5 A30X EVEN PS	Z6 A30X ODD PS	6	15A
15A	7	Z7 A40X EVEN PS	Z8 A40X ODD PS	8	15A
15A	9	Z9 A50X EVEN PS	FANS	10	15A
15A	11	Z10 A50X ODD PS	CONTROLLER	12	15A

48X48-112 (OA-1259-4305) EN-1225

PANEL BOARD

15A	1	Z1 A10X EVEN PS	Z2 A10X ODD PS	2	15A
15A	3	Z3 A20X EVEN PS	Z4 A20X ODD PS	4	15A
15A	5	Z5 A30X EVEN PS	Z6 A30X ODD PS	6	15A
15A	7	Z7 A40X EVEN PS	Z8 A40X ODD PS	8	15A
15A	9	Z9 A50X EVEN PS	Z10 A50X ODD PS	10	15A
15A	11	Z11 A60X EVEN PS	Z12 A60X ODD PS	12	15A
15A	13	FANS	CONTROLLER	14	15A
	15			16	
	17			18	
	19			20	
	21			22	
	23			24	

THE CONCEPTS EXPRESSED AND DETAILS SHOWN ON THIS DRAWING ARE CONFIDENTIAL AND PROPRIETARY. DO NOT REPRODUCE BY ANY MEANS, INCLUDING ELECTRONICALLY WITHOUT THE EXPRESSED WRITTEN CONSENT OF DAKTRONICS, INC. COPYRIGHT 2005 DAKTRONICS, INC.

DAKTRONICS, INC. BROOKINGS, SD 57006

PROJ: GALAXY, LARGE CHARACTER

TITLE: LAYOUT, PNL BD,8-48X32-112, 89mm, 1 PHASE

DES. BY: LKERR

DRAWN BY: LKERR

DATE: 16SEP02

REVISION

APPR. BY:

SCALE: 1=1

1259-R07A-175209

01	16FEB05	REVERSED BREAKERS 4 AND 5 ON ASSEMBLY OA-1259-4301	LLK	LLK
REV.	DATE	DESCRIPTION	BY	APPR.

8X32-112 (0A-1259-4310) EN-1236

PANEL BOARD

15A	1	Z1 A10X EVEN PS		2	
15A	3	Z2 A10X ODD PS		4	
15A	5	CNTRL/FANS		6	
	7			8	
	9			10	
	11			12	

16X48-112 (0A-1259-4311) EN-1236

PANEL BOARD

15A	1	Z1 A10X EVEN PS	Z2 A10X ODD PS	2	15A
15A	3	Z3 A20X EVEN PS	CNTRL/FANS	4	15A
15A	5	Z4 A20X ODD PS		6	
	7			8	
	9			10	
	11			12	

24X48-112 (0A-1259-4312) EN-1236

PANEL BOARD

15A	1	Z1 A10X EVEN PS	Z2 A10X ODD PS	2	15A
15A	3	Z3 A20X EVEN PS	Z4 A20X ODD PS	4	15A
15A	5	Z5 A30X EVEN PS	Z6 A30X ODD PS	6	15A
15A	7	CNTRL/FANS		8	
	9			10	
	11			12	

32X48-112 (0A-1259-4313) EN-1236

PANEL BOARD

15A	1	Z1 A10X EVEN PS	Z2 A10X ODD PS	2	15A
15A	3	Z3 A20X EVEN PS	Z4 A20X ODD PS	4	15A
15A	5	Z5 A30X EVEN PS	Z6 A30X ODD PS	6	15A
15A	7	Z7 A40X EVEN PS	CONTROLLER	8	15A
15A	9	Z8 A40X ODD PS		10	
15A	11	FANS		12	

40X48-112 (0A-1259-4314) EN-1236

PANEL BOARD

15A	1	Z1 A10X EVEN PS	Z2 A10X ODD PS	2	15A
15A	3	Z3 A20X EVEN PS	Z4 A20X ODD PS	4	15A
15A	5	Z5 A30X EVEN PS	Z6 A30X ODD PS	6	15A
15A	7	Z7 A40X EVEN PS	Z8 A40X ODD PS	8	15A
15A	9	Z9 A50X EVEN PS	FANS	10	15A
15A	11	Z10 A50X ODD PS	CONTROLLER	12	15A

48X48-112 (0A-1259-4315) EN-1237

PANEL BOARD

15A	1	Z1 A10X EVEN PS	Z2 A10X ODD PS	2	15A
15A	3	Z3 A20X EVEN PS	Z4 A20X ODD PS	4	15A
15A	5	Z5 A30X EVEN PS	Z6 A30X ODD PS	6	15A
15A	7	Z7 A40X EVEN PS	Z8 A40X ODD PS	8	15A
15A	9	Z9 A50X EVEN PS	Z10 A50X ODD PS	10	15A
15A	11	Z11 A60X EVEN PS	Z12 A60X ODD PS	12	15A
15A	13	FANS	CONTROLLER	14	15A
	15			16	
	17			18	
	19			20	

THE CONCEPTS EXPRESSED AND DETAILS SHOWN ON THIS DRAWING ARE CONFIDENTIAL AND PROPRIETARY. DO NOT REPRODUCE BY ANY MEANS, INCLUDING ELECTRONICALLY WITHOUT THE EXPRESSED WRITTEN CONSENT OF DAKTRONICS, INC. COPYRIGHT 2002 DAKTRONICS, INC.

DAKTRONICS, INC. BROOKINGS, SD 57006

PROJ: GALAXY, LARGE CHARACTER

TITLE: LAYOUT, PNL BD,8-48X32-112, 89mm 3 PHASE

DES. BY: LKERR

DRAWN BY: LKERR

DATE: 16SEP02

REVISION

APPR. BY:

SCALE:

1=1

1259-R07A-175212

REV.	DATE	DESCRIPTION	BY	APPR.
------	------	-------------	----	-------

REV.	DATE	DESCRIPTION	BY	APPR.
01	27 OCT 03	REPLACED 40 PIN CABLE WITH 20 PIN.	LLK	
02	22 FEB 05	REPLACED DWS WITH 4400 CHANGED TITLE FROM 3190 TO 3400.	LLK	

PROJ:	GALAXY, LARGE CHARACTER
TITLE:	SCHEMATIC, AF-3400-(8-48X32-112)-89-MONO-*-*
DES. BY:	LKERR
APPR. BY:	LKERR
SCALE:	NONE
REVISION	02
DATE:	04NOV02
1259-R03A-177829	

THE CONCEPTS EXPRESSED AND DETAILS SHOWN ON THIS DRAWING ARE CONFIDENTIAL AND PROPRIETARY. DO NOT REPRODUCE BY ANY MEANS, INCLUDING ELECTRONICALLY WITHOUT THE EXPRESS WRITTEN CONSENT OF DAKTRONICS, INC. COPYRIGHT 2005 DAKTRONICS, INC.

DAKTRONICS, INC. BROOKINGS, SD 57006

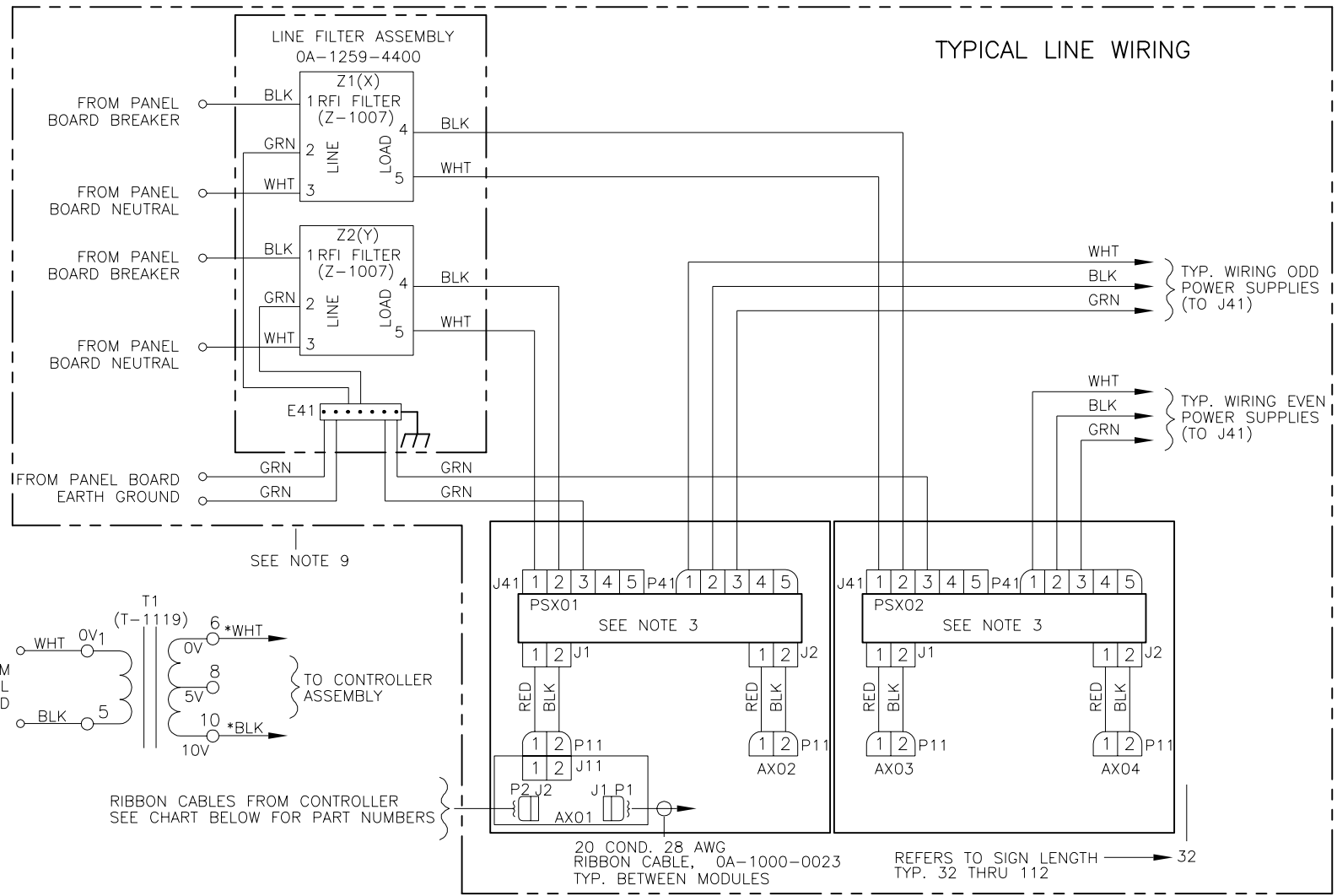

CONTROLLER OUTPUT RIBBON CABLE CHART

LINE/ PLUG#	DISPLAY HEIGHT					
	8	16	24	32	40	48
1 (P11)	0023	0023	0088	0088	0089	0090
2 (P12)	N/A	0023	0023	0088	0088	0089
3 (P13)	N/A	N/A	0023	0023	0088	0088
4 (P14)	N/A	N/A	N/A	0023	0023	0088
5 (P15)	N/A	N/A	N/A	N/A	0023	0023
6 (P16)	N/A	N/A	N/A	N/A	N/A	0023

( 0A-1000-\*\*\*\* )

NOTES

- 1) ALL WIRE IS 14 AWG EXCEPT \* IS 18 AWG UNLESS OTHERWISE NOTED.
- 2) EACH LED MODULE IS A 8X8 MATRIX.
- 3) FOR POWER SUPPLY CONFIGURATIONS REFER TO DWG A-158225.
- 4) FOR SINGLE PHASE (120/240VAC) PANEL BOARD LAYOUT REFER TO DRAWING A-175209. FOR THREE PHASE (120/208VAC) PANEL BOARD LAYOUT REFER TO DRAWING A-175212.
- 5) FOR SIGNAL AND CONTROLLER WIRING REFER TO DWG B-206146.
- 6) FOR FAN WIRING REFER TO DWG A-175194.
- 7) FOR BLOCK DIAGRAM REFER TO B-175203.
- 8) FOR DISPLAYS USING AMBER LEDS REFER TO DWG A-178168 FOR POWER SPECS.. FOR DISPLAYS USING RED LEDS REFER TO DWG A-178240 FOR POWER SPECS..
- 9) ABOVE WIRING DETAIL IS REPEATED FOR ALL SIZES IE. A 16 HIGH DISPLAY WOULD REQUIRE 2 OF THE ABOVE.

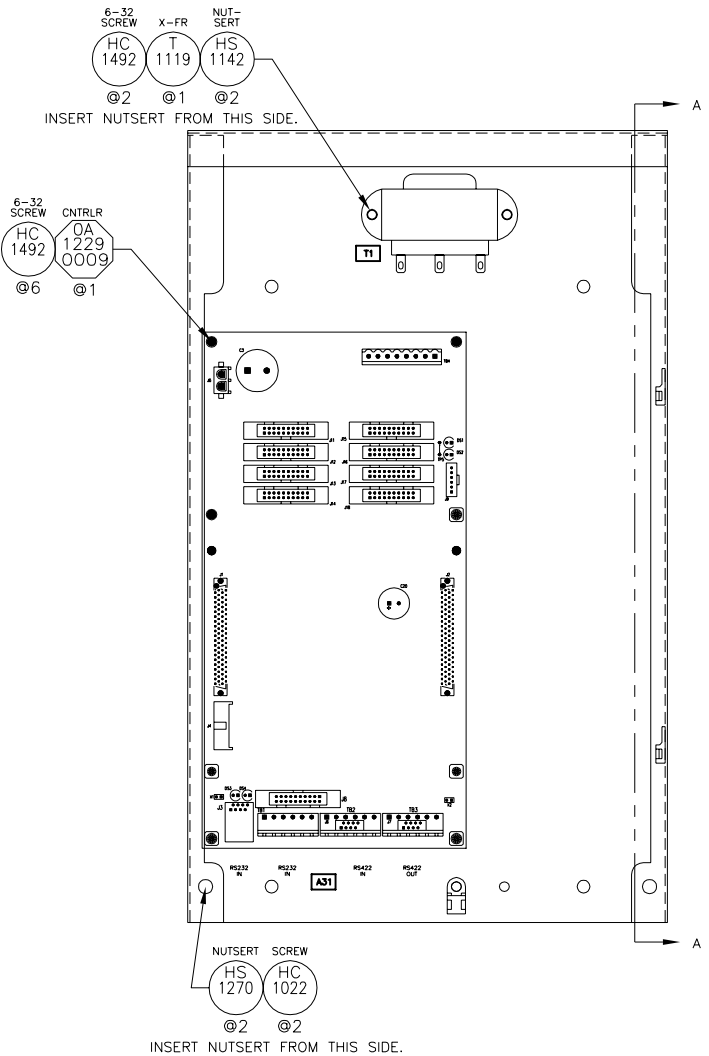

FRONT VIEW

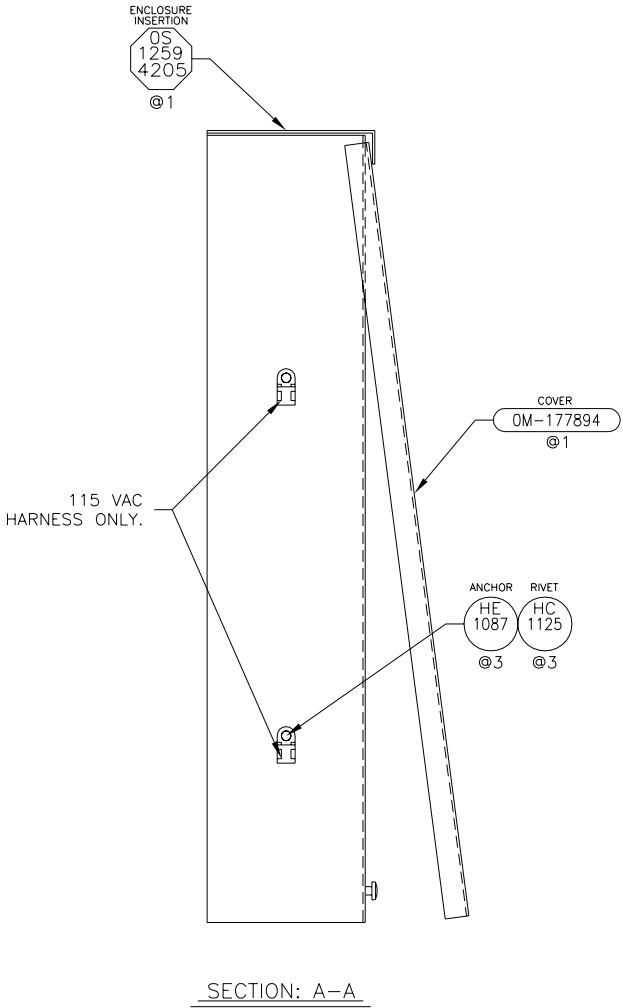

SECTION: A-A

REV.	DATE	DESCRIPTION	BY	APPR.
05	09 JUL 04	REMOVED NUSERT HS-1142 @6. REMOVED OA-177878 @1 AND ADDED OS-1259-4205 @1.	SWM	JMT
04	11 NOV 03	UPDATED CNTRLR FROM OA-1229-0005 TO OA-1229-0009	EJY	
03	15 OCT 03	DELETED: OA-1241-4015 @1, HS 1142 @4, AND HS-1492 @4.	JMT	
02	28 APR 03	ADDED OA-1241-4015 @1, HS 1142 @4, AND HS-1492 @4.	RTV	

01	25 APR 03	REMOVED HE-1087 @1 AND HC-1125 @1, AND HC-1179 @8. ADDED HC-1492 @8.	RTV	
----	-----------	---	-----	--

THE CONCEPTS EXPRESSED AND DETAILS SHOWN ON THIS DRAWING ARE CONFIDENTIAL AND PROPRIETARY. DO NOT REPRODUCE BY ANY MEANS, INCLUDING ELECTRONICALLY WITHOUT THE EXPRESSED WRITTEN CONSENT OF DAKTRONICS, INC. COPYRIGHT 2002 DAKTRONICS, INC.

DAKTRONICS, INC. BROOKINGS, SD 57006

PROJ: AF-3190 GALAXY LARGE CHARACTER

TITLE: ENCLOSURE CONTROLLER M2; RS422 ECHO

DES. BY: JMT DRAWN BY: JMT DATE: 5 NOV 02

REVISION 05 APPR. BY: RTV SCALE: 1=4 1259-E10A-177921

## GALAXY, 89mm, AMBER LEDS POWER SPECIFICATION CHART

MATRIX SIZE	WATTS	120/208, 4 WIRE + GND			120/240, 3 WIRE + GND	
		PHASE A AMPS	PHASE B AMPS	PHASE C AMPS	LINE 1 AMPS	LINE 2 AMPS
8X32	780	2.91	2.91	0.68	3.59	2.91
8X48	1174	2.91	5.83	1.04	3.95	5.83
8X64	1567	5.83	5.83	1.41	7.23	5.83
8X80	1961	5.83	8.74	1.78	7.60	8.74
8X96	2354	8.74	8.74	2.14	10.88	8.74
8X112	2748	8.74	11.65	2.51	11.25	11.65
16X48	2352	8.74	5.04	5.83	10.86	8.74
16X64	3132	11.65	8.62	5.83	14.44	11.65
16X80	3911	14.57	9.28	8.74	18.02	14.57
16X96	4690	17.48	12.86	8.74	21.60	17.48
16X112	5469	20.39	13.53	11.65	25.18	20.39
24X48	3401	10.86	8.74	8.74	13.78	14.57
24X64	4530	14.44	11.65	11.65	20.27	17.48
24X80	5658	18.02	14.57	14.57	23.85	23.30
24X96	6787	21.60	17.48	17.48	30.34	26.22
24X112	7916	25.18	20.39	20.39	33.92	32.04
32X48	4690	11.78	14.57	12.74	21.60	17.48
32X64	6248	17.60	17.48	16.99	28.76	23.30
32X80	7806	20.52	23.30	21.23	35.92	29.13
32X96	9365	26.34	26.22	25.48	43.08	34.96
32X112	10923	29.26	32.04	29.72	50.24	40.78
40X48	5738	17.48	15.65	14.69	24.52	23.30
40X64	7646	23.30	22.81	17.60	34.59	29.13
40X80	9554	29.13	27.06	23.43	41.75	37.87
40X96	11462	34.96	34.22	26.34	51.82	43.70
40X112	13370	40.78	38.46	32.17	58.98	52.43
48X48	6787	21.60	17.48	17.48	30.34	26.22
48X64	9045	28.76	23.30	23.30	40.41	34.96
48X80	11302	35.92	29.13	29.13	50.49	43.70
48X96	13559	43.08	34.96	34.96	60.56	52.43
48X112	15817	50.24	40.78	40.78	70.63	61.17

**NOTES:**

- SPECS LISTED ABOVE ARE FOR A SINGLE FACE DISPLAY.

POWER DISTRIBUTION/  
DISCONNECT PANEL  
BY CUSTOMER



THE CONCEPTS EXPRESSED AND DETAILS SHOWN ON THIS DRAWING ARE CONFIDENTIAL AND PROPRIETARY. DO NOT REPRODUCE BY ANY MEANS, INCLUDING ELECTRONICALLY WITHOUT THE EXPRESSED WRITTEN CONSENT OF DAKTRONICS, INC. COPYRIGHT 2005 DAKTRONICS, INC.			
DAKTRONICS, INC. BROOKINGS, SD 57006			
PROJ: GALAXY, LARGE CHARACTER			
TITLE: P SPECS, AF-3400-(8-48X32-112)-89-A-*-*			
DES. BY:		DRAWN BY: DMATHERN	
		DATE: 08NOV02	
<b>REVISION</b>	APPR. BY:	1259-R10A-178168	
02	SCALE: NONE		

REV.	DATE	DESCRIPTION	BY	APPR.
02	01 NOV 05	UPDATED SPECS ON 8 HIGH DISPLAYS DUE TO FAN CHANGING FROM B-1019 TO B-1053	LLK	
01	16 FEB 05	UPDATED SPECIFICATION CHART.	WRS	LLK

04	21 AUG 06	CHANGED HC-1022 TO HC-1233	JMP
03	21OCT05	CHANGED HC-1233 TO HC-1022	JTELLIN
02	19SEP05	UPDATED CHANGES PER ECO 048652	NKJ
01	12SEP05	ADDED DETAIL: A	NKJ
REV.	DATE	DESCRIPTION	BY

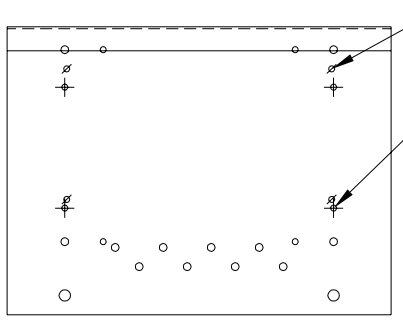

DETAIL: A

SMALL DRVR ATTACHED IN THESE HOLES (OP-1261-4100)

LARGE DRVR ATTACHED IN THESE HOLES (OP-1261-0008)

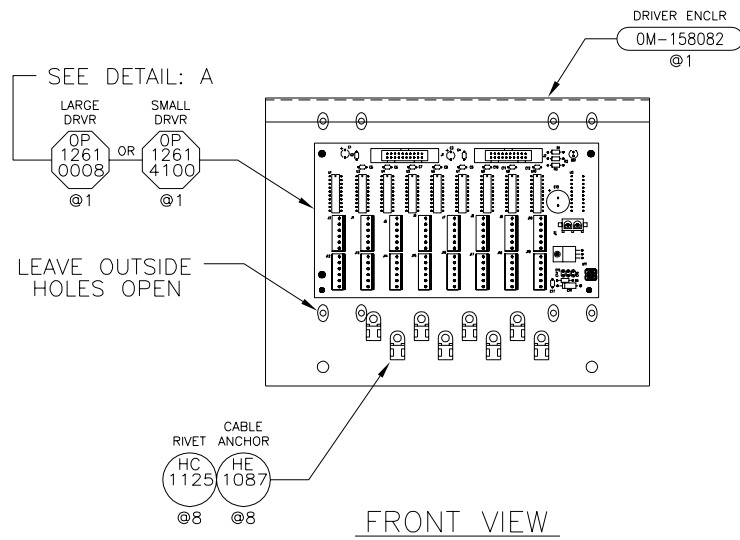

FRONT VIEW

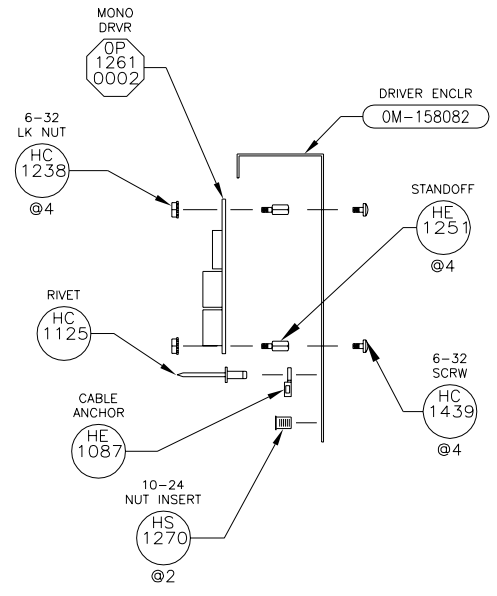

RIGHT SIDE

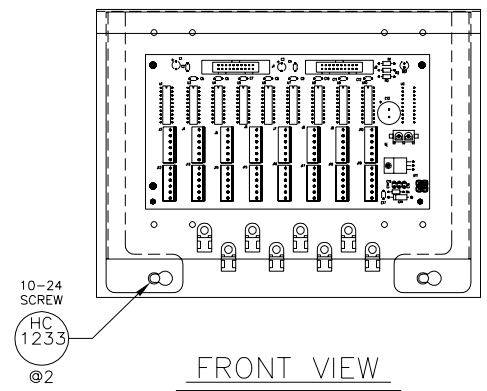

FRONT VIEW  
(COMPLETED ASSEMBLY)

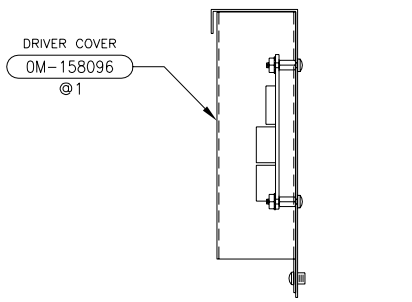

RIGHT SIDE  
(COMPLETED ASSEMBLY)

THE CONCEPTS EXPRESSED AND DETAILS SHOWN ON THIS DRAWING ARE CONFIDENTIAL AND PROPRIETARY. DO NOT REPRODUCE BY ANY MEANS, INCLUDING ELECTRONICALLY WITHOUT THE EXPRESSED WRITTEN CONSENT OF DAKTRONICS, INC. COPYRIGHT 2002 DAKTRONICS, INC.

DAKTRONICS, INC. BROOKINGS, SD 57006

PROJ: AF-3190 GALAXY, LARGE CHARACTER

TITLE: DRIVER ASSY; AF-3190, 8X8-89MM-MONO

DES. BY: JMT

DRAWN BY: JMT

DATE: 8 NOV 02

REVISION 04

APPR. BY: SCALE: 1=5

1259-E10A-178210



## GALAXY, 89mm, RED LEDS POWER SPECIFICATION CHART

MATRIX SIZE	WATTS	120/208, 4 WIRE + GND			120/240, 3 WIRE + GND	
		PHASE A AMPS	PHASE B AMPS	PHASE C AMPS	LINE 1 AMPS	LINE 2 AMPS
8X32	366	1.19	1.19	0.68	1.86	1.19
8X48	553	1.19	2.38	1.04	2.23	2.38
8X64	740	2.38	2.38	1.41	3.79	2.38
8X80	927	2.38	3.57	1.78	4.15	3.57
8X96	1113	3.57	3.57	2.14	5.71	3.57
8X112	1300	3.57	4.76	2.51	6.08	4.76
16X48	1111	3.57	3.31	2.38	4.50	4.76
16X64	1477	4.76	5.17	2.38	7.55	4.76
16X80	1842	5.95	5.84	3.57	8.22	7.14
16X96	2208	7.14	7.69	3.57	11.26	7.14
16X112	2573	8.33	8.36	4.76	11.93	9.52
24X48	1540	5.69	3.57	3.57	6.88	5.95
24X64	2048	7.55	4.76	4.76	9.93	7.14
24X80	2556	9.41	5.95	5.95	11.78	9.52
24X96	3064	11.26	7.14	7.14	14.83	10.71
24X112	3572	13.12	8.33	8.33	16.69	13.08
32X48	2208	4.88	5.95	7.57	11.26	7.14
32X64	2939	7.26	7.14	10.09	14.97	9.52
32X80	3670	8.45	9.52	12.61	18.69	11.89
32X96	4401	10.83	10.71	15.14	22.40	14.27
32X112	5132	12.02	13.08	17.66	26.11	16.65
40X48	2636	7.14	8.76	6.07	12.45	9.52
40X64	3510	9.52	12.47	7.26	17.35	11.89
40X80	4383	11.89	14.99	9.64	21.07	15.46
40X96	5257	14.27	18.71	10.83	25.97	17.84
40X112	6131	16.65	21.23	13.21	29.68	21.41
48X48	3064	11.26	7.14	7.14	14.83	10.71
48X64	4081	14.97	9.52	9.52	19.73	14.27
48X80	5097	18.69	11.89	11.89	24.63	17.84
48X96	6114	22.40	14.27	14.27	29.54	21.41
48X112	7130	26.11	16.65	16.65	34.44	24.98

**NOTES:**

1. SPECS LISTED ABOVE ARE FOR A SINGLE FACE DISPLAY.

POWER DISTRIBUTION/  
DISCONNECT PANEL  
BY CUSTOMER



THE CONCEPTS EXPRESSED AND DETAILS SHOWN ON THIS DRAWING ARE CONFIDENTIAL AND PROPRIETARY. DO NOT REPRODUCE BY ANY MEANS, INCLUDING ELECTRONICALLY WITHOUT THE EXPRESSED WRITTEN CONSENT OF DAKTRONICS, INC. COPYRIGHT 2005 DAKTRONICS, INC.			
DAKTRONICS, INC. BROOKINGS, SD 57006			
PROJ: GALAXY, LARGE CHARACTER			
TITLE: P SPECS, AF-3400-(8-48X32-112)-89-R-*-*			
DES. BY:		DRAWN BY: DMATHERN	
		DATE: 11NOV02	
<b>REVISION</b>	APPR. BY:	1259-R10A-178240	
02	SCALE: NONE		

02	01 NOV 05	UPDATED SPECS ON 8 HIGH DISPLAYS DUE TO FAN CHANGING FROM B-1019 TO B-1053.	LLK	
01	16 FEB 05	UPDATED SPECIFICATION CHART.	WRS	LLK
REV.	DATE	DESCRIPTION	BY	APPR.

REV.	DATE	DESCRIPTION	BY	APPR.
01	25JUN03	REVISED NOTE 2 FROM W-1210 22 AWG TO W-1370 18 AWG. ADDED MAX LENGTH OF W-1370 TO 1000'.	KAP	
02	26DEC03	CHANGED TEMP SENSOR PART NUMBER FROM 0A-1241-4017 TO 0A-1151-0005.	DJM	
03	29MAR05	CHANGED 1-BOX 0A-1279-0162 TO 0A-1279-0168	HBC	

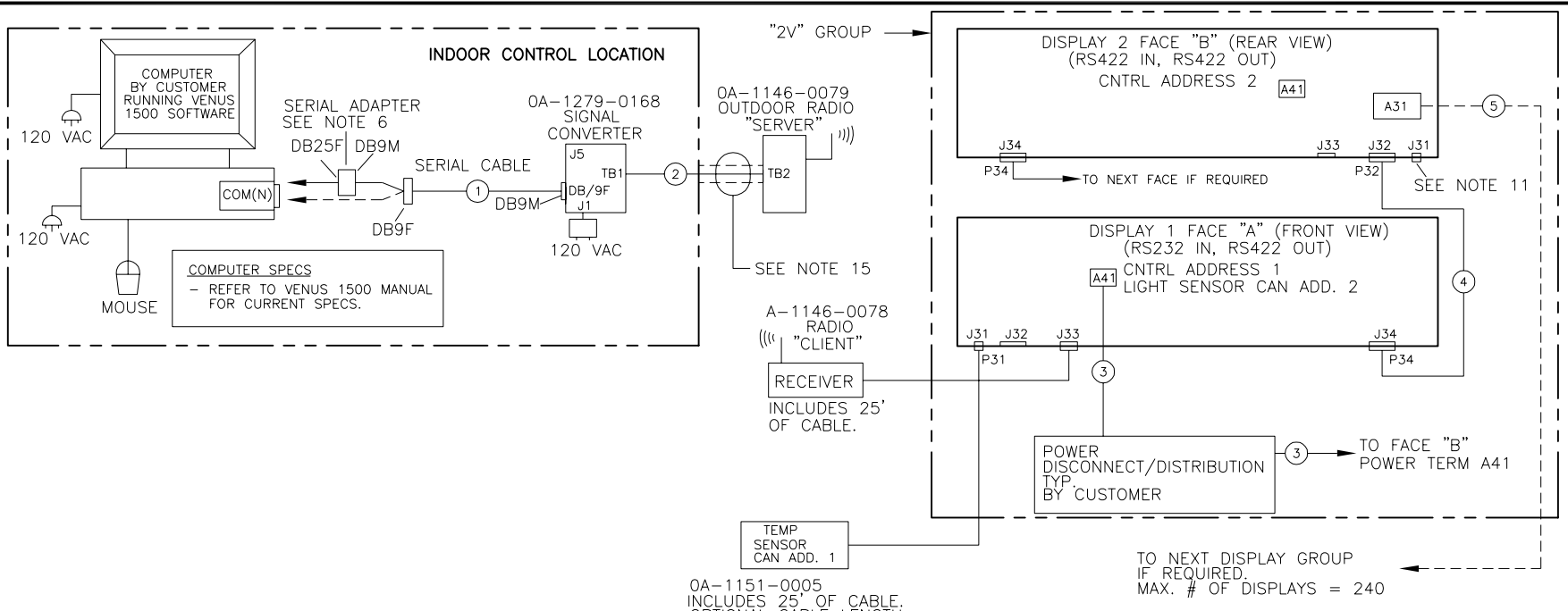

0A-1151-0005 INCLUDES 25' OF CABLE. OPTIONAL CABLE LENGTH 500FT. MAX

MAX. # OF DROPS PER CAN NETWORK IS 10.

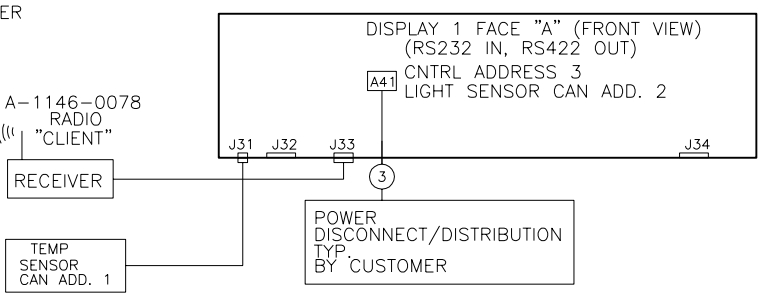

NOTES

- DB9F TO DB9M SERIAL CABLE DAK. P.N. (W-1267)
- 6 CONDUCTOR, 18 AWG, STRANDED SHIELDED CABLE. DAK. P.N. (W-1370). IN CONDUIT WHERE REQUIRED. FIELD SIGNAL TERMINATIONS TO BE PHOENIX TERMINAL BLOCKS. FIELD CABLES ARE PINNED 1 TO 1 FROM ONE END TO THE OTHER, TO A MAXIMUM OF 1000'.
- POWER FEEDER SIZED AS NEEDED BY CUSTOMER
- 10 CONDUCTOR, 18 AWG, STRANDED SHIELDED CABLE. DAK. P.N. (W-1483). LENGTH TO BE 4 FT MAX. FIELD SIGNAL TERMINATIONS TO BE 10 POS QUICK CONNECT. SUPPLIED WITH FACE "B".
- 4 CONDUCTOR, 22 AWG, STRANDED SHIELDED CABLE. DAK. P.N. (W-1234). MANHATTAN P.N. (M4473) OR EQUIV. IN CONDUIT WHERE REQUIRED. FIELD SIGNAL TERMINATIONS TO BE TERMINAL BLOCK.
- USE EITHER THE DB9 OR DB25, DEPENDING ON YOUR PC'S REQUIREMENTS. DAK. P.N. (A-1603)
- ALL SIGNAL CABLES BY CUSTOMER. LABOR TO PULL CABLES BY CUSTOMER.
- ALL POWER WIRES BY CUSTOMER. LABOR TO PULL WIRES BY CUSTOMER.
- ALL WIRING TO MEET NEC AND LOCAL ELECTRICAL CODES.
- DISPLAYS MUST BE GROUNDED PER ARTICLE 250 AND 600 OF THE NATIONAL ELECTRICAL CODE.
- LAST DISPLAY IN A GROUP REQUIRES A CAN TERMINATION RESISTOR (INSTALLED AT FACTORY). REFER TO THE DISPLAY MANUAL FOR CAN TERMINATOR LOCATION. \*\*\*BELOW ONLY APPLIES TO AF-3165 (TYPE 1)\*\*\* TERMINATOR PLUG (DAK P.N. 0A-1241-4010) MUST BE INSTALLED ON LAST DISPLAY IN EACH GROUP.
- A31 = DISPLAY CONTROLLER  
A41 = POWER TERMINATION PANEL
- SERVER AND CLIENT(S) MUST BE SET TO SAME CHANNEL. (VIA SOFTWARE OR ON-BOARD SWITCHES) ALL CLIENT DISPLAYS MUST HAVE A UNIQUE ADDRESS. TOTAL SYSTEM CANNOT EXCEED 240 DISPLAYS.
- IN AREAS USING MULTIPLE SERVER/CLIENT SYSTEMS WITHIN CLOSE PROXIMITY OF EACH OTHER, ALTERNATE CHANNELS MUST BE USED, TO AVOID INTERFERENCE BETWEEN SYSTEMS.
- CABLE TO BE IN CONDUIT WHERE EXPOSED TO OUTDOOR ELEMENTS.

THE CONCEPTS EXPRESSED AND DETAILS SHOWN ON THIS DRAWING ARE CONFIDENTIAL AND PROPRIETARY. DO NOT REPRODUCE BY ANY MEANS, INCLUDING ELECTRONICALLY WITHOUT THE EXPRESSED WRITTEN CONSENT OF DAKTRONICS, INC. COPYRIGHT 2003 DAKTRONICS, INC.

PROJ: OUTDOOR LED PRODUCT LINE

TITLE: SYSTEM RISER DIAGRAM, QC OUTDOOR RADIO, GEN 2

DES. BY: LKERR

REVISION 03

APPR. BY: DATE: 20MAR03

SCALE: NONE

1229-R01A-185359

DAKTRONICS, INC. BROOKINGS, SD 57006

REV.	01	DATE	13MAY05	DESCRIPTION	REMOVED SURGE CARD AND HARDWARE:	BY	SMM	APPR.	JMT
------	----	------	---------	-------------	----------------------------------	----	-----	-------	-----

REVISION	01	APPR. BY:	JTELLIN	DATE:	30NOV04
SCALE:	1=4	1259-E10A-228684			
THE CONCEPTS EXPRESSED AND DETAILS SHOWN ON THIS DRAWING ARE CONFIDENTIAL AND PROPRIETARY. DO NOT REPRODUCE BY ANY MEANS, INCLUDING ELECTRONICALLY WITHOUT THE EXPRESSED WRITTEN CONSENT OF DAKTRONICS, INC. COPYRIGHT 2002 DAKTRONICS, INC.					
DAKTRONICS, INC. BROOKINGS, SD 57006					
PROJ: AF-3190 GALAXY LARGE CHARACTER					
TITLE: ENCLOSURE CONTROLLER M2; RS232/422 (0013)					
DES. BY: JTELLIN DRAWN BY: SMENNIN					

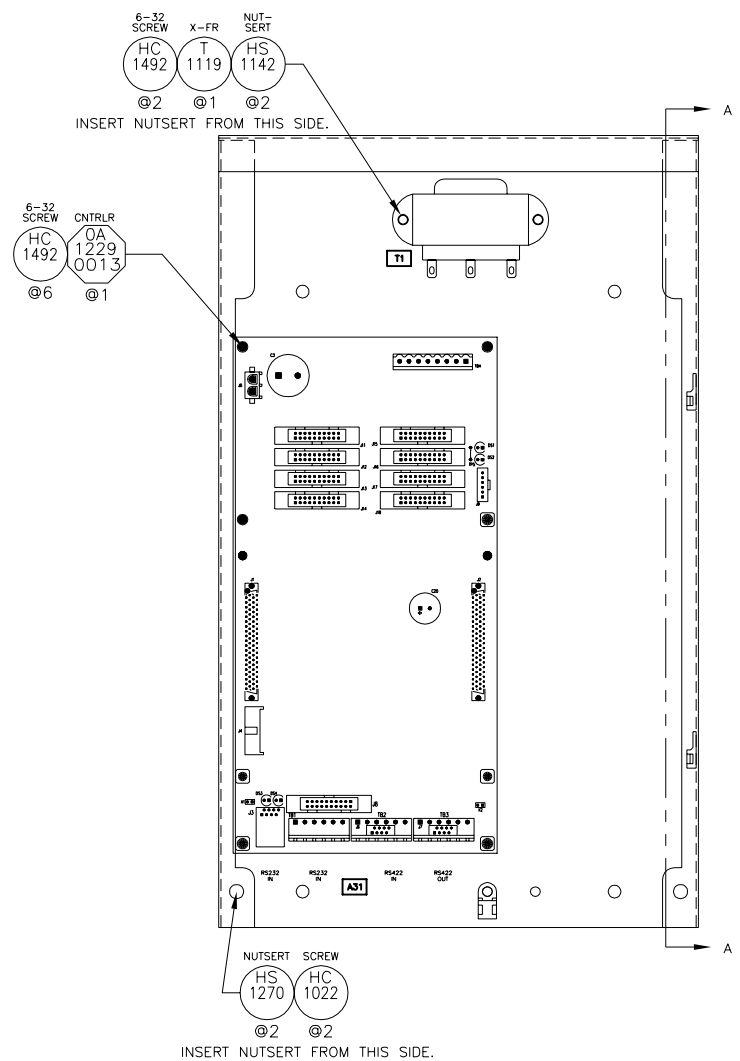
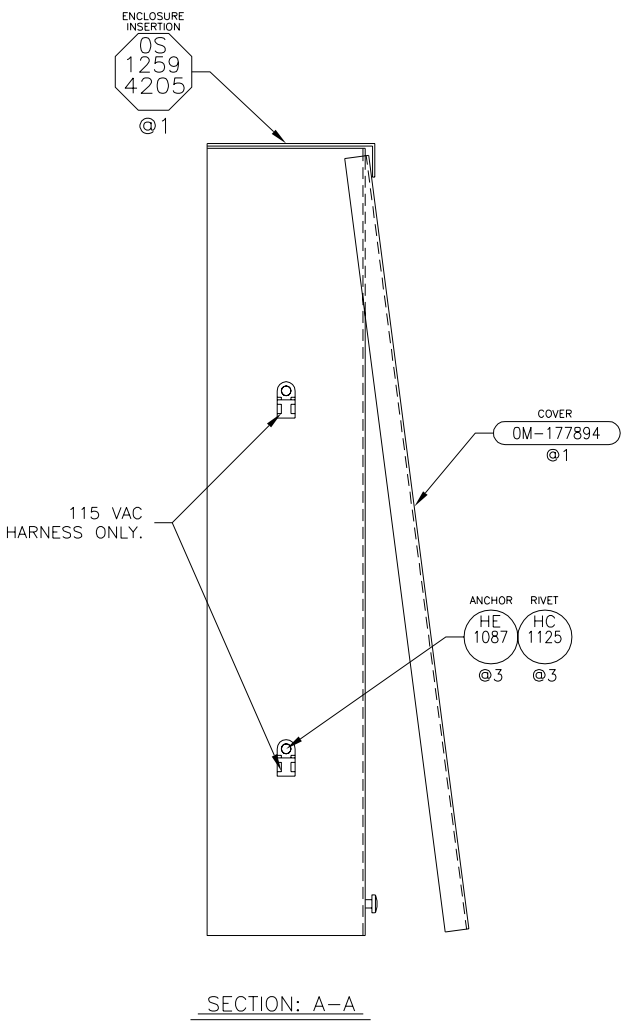

REV.	DATE	DESCRIPTION	BY	APPR.
00				
THE CONCEPTS EXPRESSED AND DETAILS SHOWN ON THIS DRAWING ARE CONFIDENTIAL AND PROPRIETARY. DO NOT REPRODUCE BY ANY MEANS, INCLUDING ELECTRONICALLY WITHOUT THE EXPRESSED WRITTEN CONSENT OF DAKTRONICS, INC. COPYRIGHT 2002 DAKTRONICS, INC.				
<b>DAKTRONICS, INC. BROOKINGS, SD 57006</b>				
PROJ.: AF-3190 GALAXY LARGE CHARACTER TITLE: ENCLOSURE CONTROLLER M2; MODEM (0013) DES. BY: JTELLIN DRAWN BY: SMENNIN DATE: 30NOV04				
REVISION	APPR. BY:	SCALE:	1259-E10A-228685	
00		1=4		

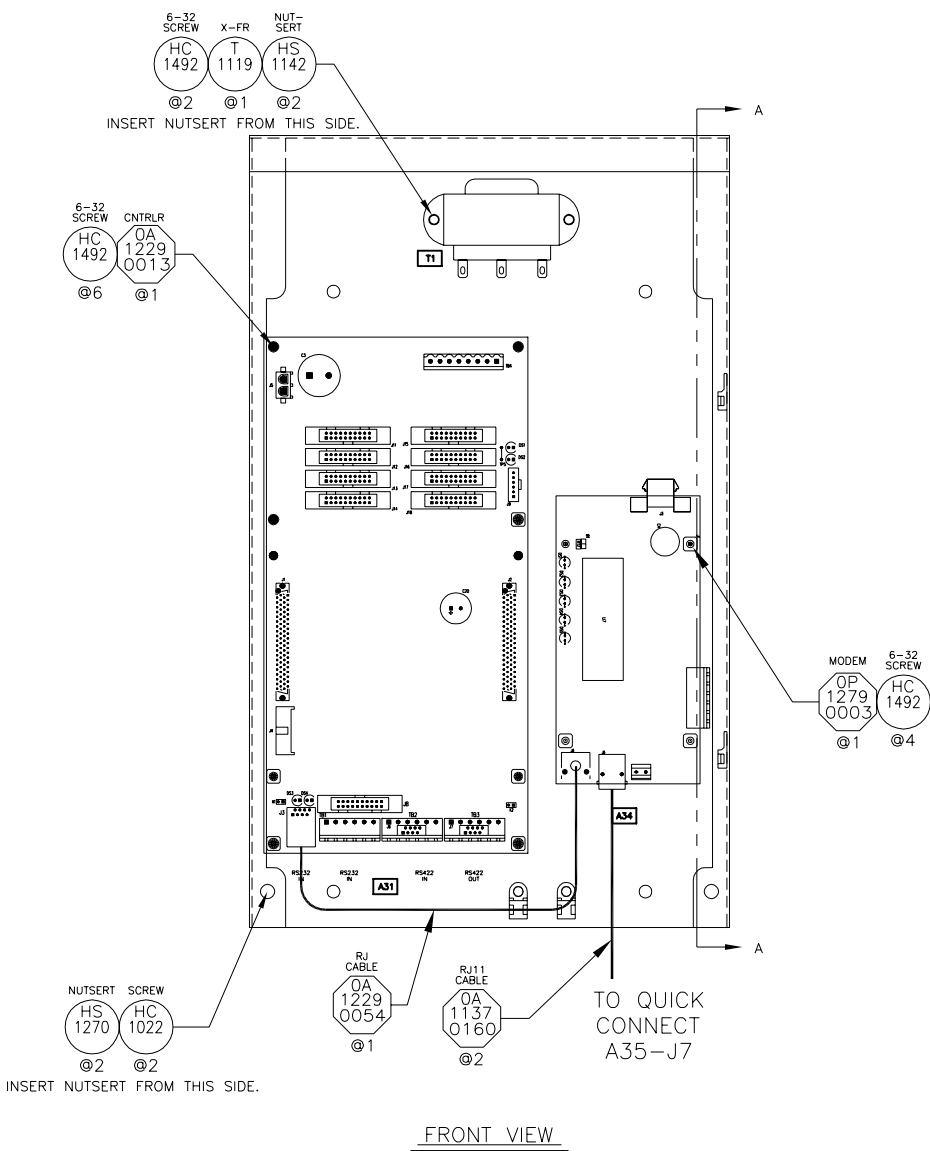
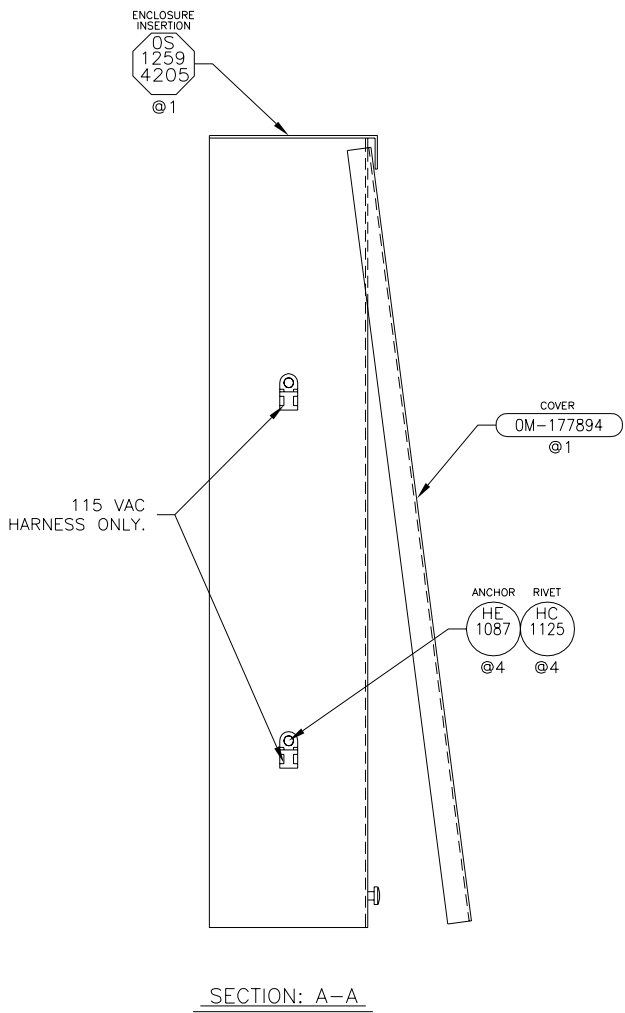

REV.	DATE	DESCRIPTION	BY	APPR.
00				
THE CONCEPTS EXPRESSED AND DETAILS SHOWN ON THIS DRAWING ARE CONFIDENTIAL AND PROPRIETARY. DO NOT REPRODUCE BY ANY MEANS, INCLUDING ELECTRONICALLY WITHOUT THE EXPRESSED WRITTEN CONSENT OF DAKTRONICS, INC. COPYRIGHT 2002 DAKTRONICS, INC.				
<b>DAKTRONICS, INC. BROOKINGS, SD 57006</b>				
PROJ.: AF-3190 GALAXY LARGE CHARACTER TITLE: ENCLOSURE CONTROLLER M2; FIBER (0013) DES. BY: JTELLIN DRAWN BY: SMENNIN DATE: 30NOV04				
REVISION	APPR. BY:	SCALE:	1259-E10A-228687	
00		1=4		

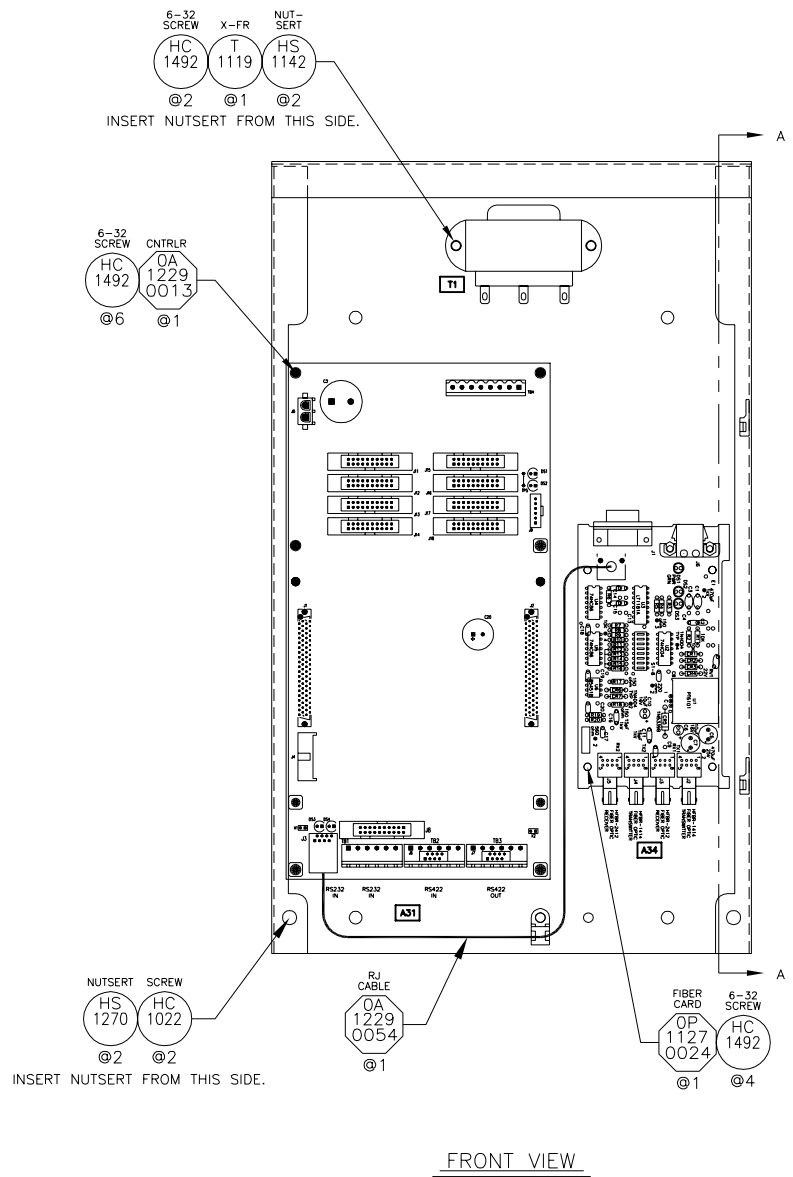
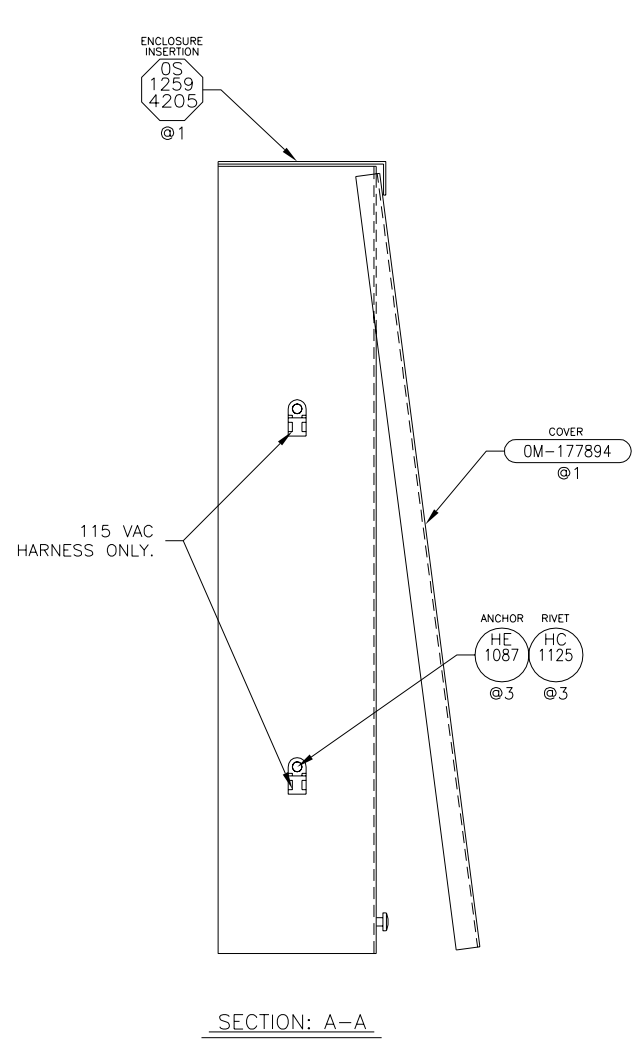

REV.	01	DATE	06JUN05	DESCRIPTION	REMOVED HS-1142 NUTSERTS	BY	NKJ	APPR.	JMT
------	----	------	---------	-------------	--------------------------	----	-----	-------	-----

THE CONCEPTS EXPRESSED AND DETAILS SHOWN ON THIS DRAWING ARE CONFIDENTIAL AND PROPRIETARY. DO NOT REPRODUCE BY ANY MEANS, INCLUDING ELECTRONICALLY WITHOUT THE EXPRESSED WRITTEN CONSENT OF DAKTRONICS, INC. COPYRIGHT 2004 DAKTRONICS, INC.

DAKTRONICS, INC. BROOKINGS, SD 57006

PROD: GALAXY, AF-3180-64MM  
 TITLE: ENCLOSURE CONTROLLER M2; ETHERNET WIRE  
 DES. BY: JTELLIN DRAWN BY: JHELLER DATE: 13 DEC 04  
 REVISION 01 APPR. BY: SCALE: 1=4

1307-E10A-229387

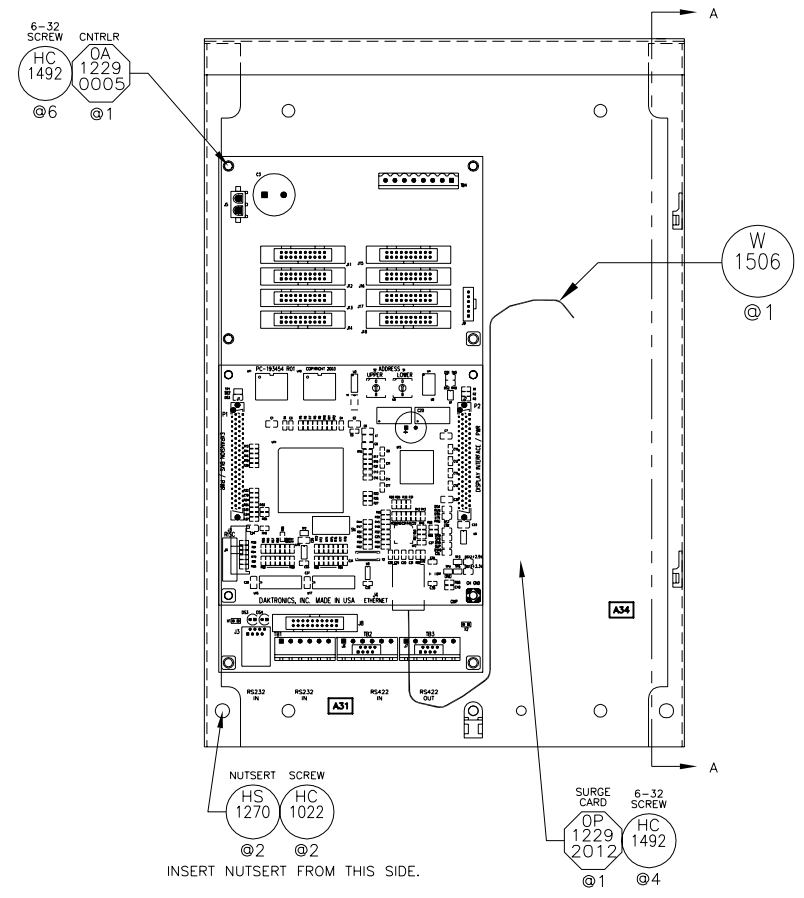
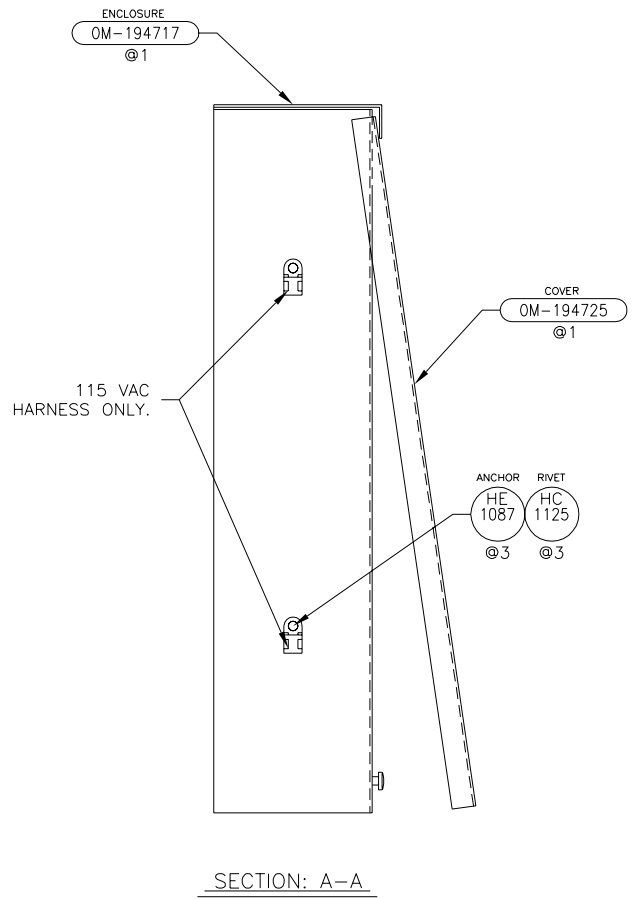

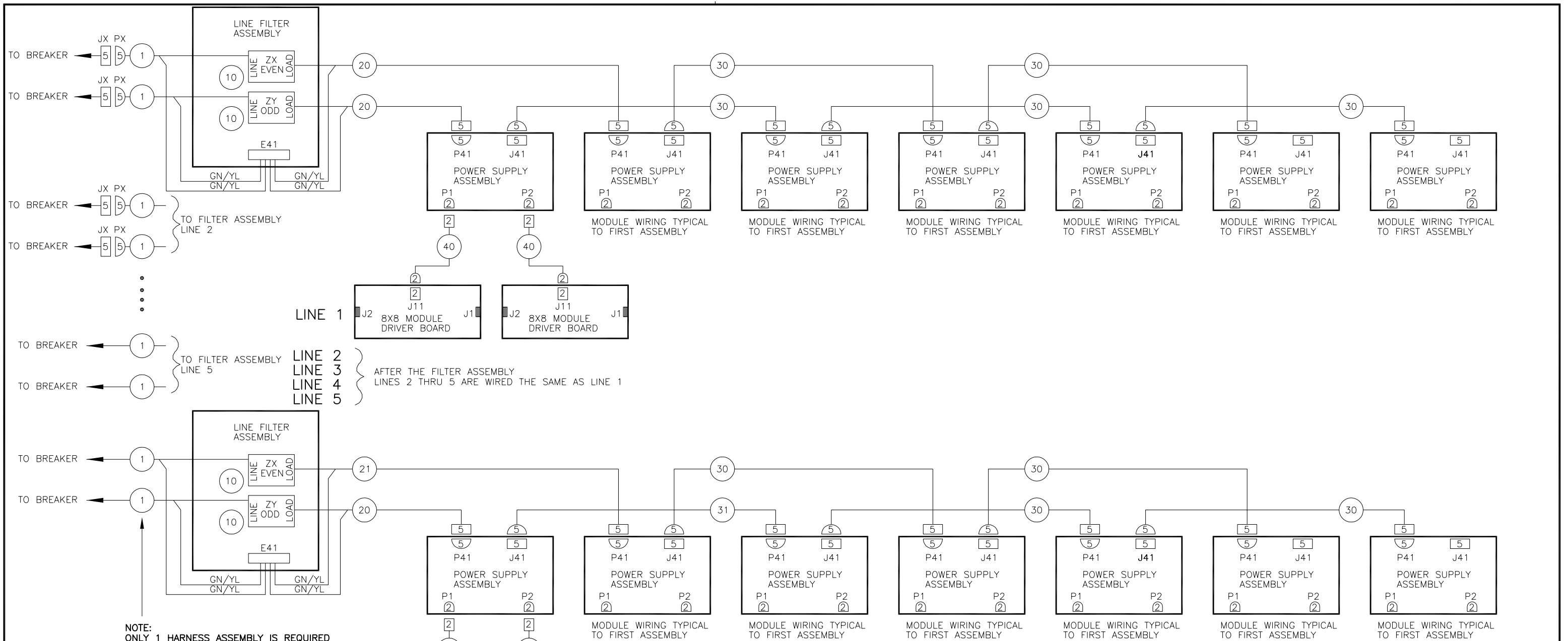

NOTE: ONLY 1 HARNESS ASSEMBLY IS REQUIRED PER DISPLAY. PLUG/JACK CONFIGURATION IS REQUIRED ONLY ON THE TOP SECTION OF MULTIPLE SECTION DISPLAYS.

- 1 OA-1259-4100 HARN, FILTER TO PNL BD 8 HIGH (14AWG)
- 1 OA-1259-4101 HARN, FILTER TO PNL BD 16 HIGH (14AWG)
- 1 OA-1259-4102 HARN, FILTER TO PNL BD 24 HIGH (14AWG)
- 1 OA-1259-4103 HARN, FILTER TO PNL BD 32 HIGH (14AWG)
- 1 OA-1259-4104 HARN, FILTER TO PNL BD 40 HIGH (14AWG)
- 1 OA-1259-4105 HARN, FILTER TO PNL BD 48 HIGH (14AWG)
- 10 OA-1175-2017 HARN, FILTER GND 6IN (14AWG)
- 20 OA-1259-4111 HARN, PWR, FILTER TO POWER SUPPLY 6FT (14AWG)
- 21 OA-1259-4112 HARN, PWR, FILTER TO POWER SUPPLY 10FT (14AWG)
- 30 OA-1259-4113 HARN, PWR, INTC, 5 PIN PLUG TO 5 PIN JACK 10FT (14AWG)

- 31 OA-1259-4114 HARN, PWR, INTC, 5 PIN PLUG TO 5 PIN JACK 14FT (14AWG)
- 40 OA-1259-4403 HARN, PS TO MOD, 4FT (14AWG)
- 60 OA-1259-4109 HARN, GROUNDING & FAN, 8-24X32-112 (14AWG) (FOR BOTTOM SECTION)
- 61 OA-1259-4110 HARN, GROUNDING & FAN, W/INTERCONNECT (14AWG) (FOR TOP SECTION)

BLOCK DIAGRAM, POWER, 8-48 HIGH DISPLAYS.

- SINGLE SECTION DISPLAYS
  - 8 HIGH DISPLAYS USE LINE 6 WIRING.
  - 16 HIGH DISPLAYS USE LINES 5 THRU 6 WIRING.
  - 24 HIGH DISPLAYS USE LINES 4 THRU 6 WIRING.
- TWO SECTION DISPLAYS
  - 32 HIGH DISPLAYS USE LINES 3 THRU 6 WIRING.
  - 40 HIGH DISPLAYS USE LINES 2 THRU 6 WIRING.
  - 48 HIGH DISPLAYS USE LINES 1 THRU 6 WIRING.

THE CONCEPTS EXPRESSED AND DETAILS SHOWN ON THIS DRAWING ARE CONFIDENTIAL AND PROPRIETARY. DO NOT REPRODUCE BY ANY MEANS, INCLUDING ELECTRONICALLY WITHOUT THE EXPRESSED WRITTEN CONSENT OF DAKTRONICS, INC. COPYRIGHT 2005 DAKTRONICS, INC.			
DAKTRONICS, INC. BROOKINGS, SD 57006			
PROJ: GALAXY, LARGE CHARACTER			
TITLE: BLOCK DIAG., PWR, AF-3400-(8-48X32-112)-89-M-*-*			
DES. BY: LKERR	DRAWN BY: LKERR		DATE: 16SEP02
REVISION	APPR. BY:	1259-R01B-175203	
01	SCALE: NONE		

REV.	DATE	DESCRIPTION	BY	APPR.
01	16 FEB 05	CHANGED WIRE COLOR GRN TO GN/YL. REMOVED A-1259-4405 REPLACED WITH A-1259-4403.	WRS	LLK

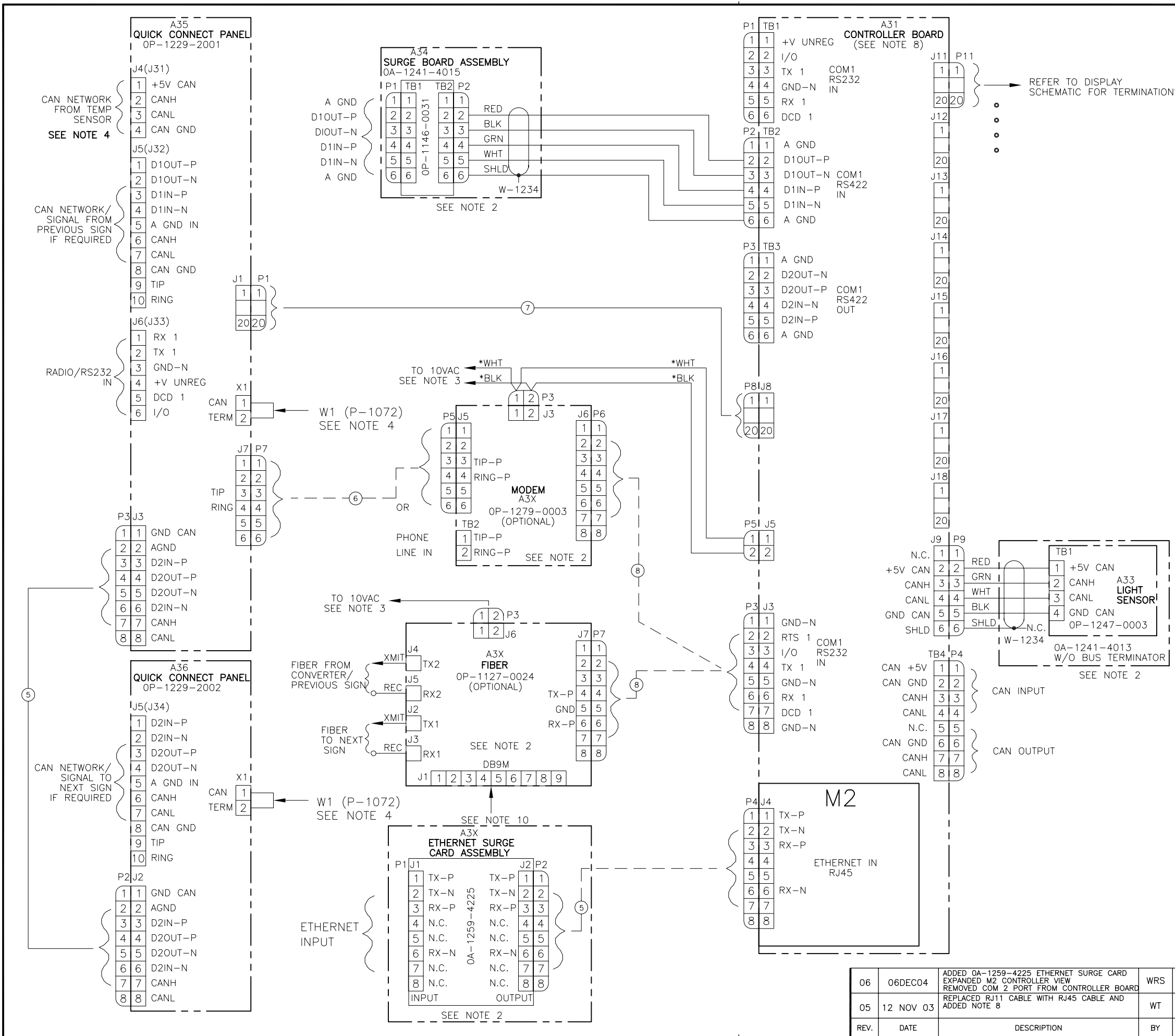

- NOTES:
- 1) ALL WIRE IS 22 AWG EXCEPT \* IS 18 AWG UNLESS OTHERWISE NOTED.
  - 2) THE LIGHT SENSOR, SURGE BOARD, MODEM, FIBER CARD, AND WIRING ARE LOCATED IN THE PRIMARY DISPLAY ONLY. NOTE, ONLY ONE COMMUNICATION METHOD CAN BE USED AT ONE TIME.
  - 3) REFER TO DISPLAY SCHEMATIC FOR COMPLETE DISPLAY WIRING. MODEM AND FIBER ARE OPTIONAL. THE 10VAC (P3) WILL POWER WHICH EVER OPTION IS USED.
  - 4) REFER TO BELOW DIAGRAMS FOR W1 JUMPER LOADING DETAIL. THE CAN LINE MUST BE TERMINATED AT BOTH ENDS OF THE DISPLAY NETWORK. NOT ALL POSSIBILITIES ARE SHOWN.

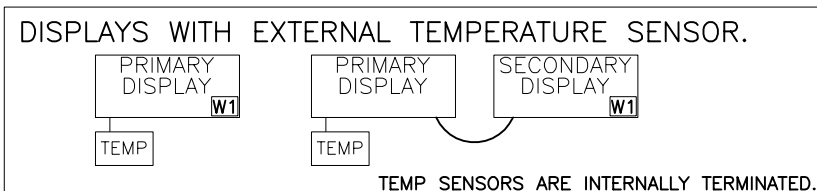
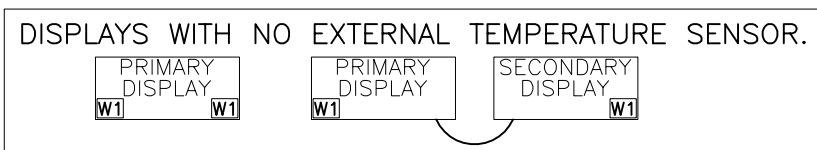

- 5) CAT 5 PATCH CABLE (RJ45 CABLE, 8 PIN 1 TO 1) 24 AWG, DAK P.N. (W-1506)
- 6) RJ11 CABLE. 6 COND, 26 AWG, FLAT; PINNED 1 TO 1. DAK P.N. (0A-1137-0160)
- 7) 20 PIN 1 TO 1 RIBBON CABLE, (.05 CENTER TO CENTER) (REFER TO CHART 1 FOR FUNCTIONS)

CHART 1

PIN#	FUNCTION	PIN#	FUNCTION
1	D11N-P	A	I/O
2	D11N-N	B	D10UT-P
3	+V UNREG	C	D10UT-N
4	TX COM1	D	AGND IN
5	GND	E	D20UT-N
6	D20UT-P	F	D2IN-N
7	RX COM1	H	D2IN-P
8	DCD COM1	J	AGND
9	CANH	K	+5V CAN
10	CANL	L	GND CAN

- 8) RJ45 CABLE, 8 COND. M-M, ST PINNING, 18 INCH DAK P.N. (0A-1229-0054)
- 9) PART NUMBER IS 0A-1229-0005 FOR AF-31XX DISPLAYS, EXCEPT FOR AF-3190 & AF-3197, PART NUMBER IS 0A-1229-0009.
- 10) IF FIBER CARD IS BELOW REVISION 10, PC ADAPTOR(0A-1146-0029) IS REQUIRED TO CONNECT RJ11 CABLE FROM A31 J3 TO J1 OF FIBER CARD.

04	08OCT03	ADDED NOTE ABOUT CONTROLLER PART CHANGING WITH AF-3190 & AF-3197 DISPLAYS.	DJM
03	09SEPT03	ADDED DETAIL A. J7 WAS ADDED ON REVISION 10 OF FIBER CARD. PC ADAPTOR IS NO LONGER REQUIRED FOR CONNECTION TO CONTROLLER.	DJM
02	10JULY03	REPLACED FACE A AND B NOTES WITH PRIMARY AND SECONDARY DISPLAY NOTES	WRT
01	28JAN03	ADDED CAN TERMINATION JUMPER AND REVISED NOTE # 4 TO REFLECT THE CHANGE.	DJM

THE CONCEPTS EXPRESSED AND DETAILS SHOWN ON THIS DRAWING ARE CONFIDENTIAL AND PROPRIETARY. DO NOT REPRODUCE BY ANY MEANS, INCLUDING ELECTRONICALLY WITHOUT THE EXPRESSED WRITTEN CONSENT OF DAKTRONICS, INC. COPYRIGHT 2002 DAKTRONICS, INC.

DAKTRONICS, INC. BROOKINGS, SD 57006

PROJ:	GALAXY, LOUVERED, V1500
TITLE:	SCHEM, SIG WIRING, INTERNAL, W/QUICK CONNECT PCB
DES. BY:	PGILK
DRAWN BY:	LKERR
DATE:	30OCT02
REVISION	APPR. BY:
06	SCALE: NONE

REV.	DATE	DESCRIPTION	BY	APPR.
06	06DECO4	ADDED 0A-1259-4225 ETHERNET SURGE CARD EXPANDED M2 CONTROLLER VIEW REMOVED COM 2 PORT FROM CONTROLLER BOARD	WRS	DJM
05	12 NOV 03	REPLACED RJ11 CABLE WITH RJ45 CABLE AND ADDED NOTE 8	WT	

1229-R03B-177662





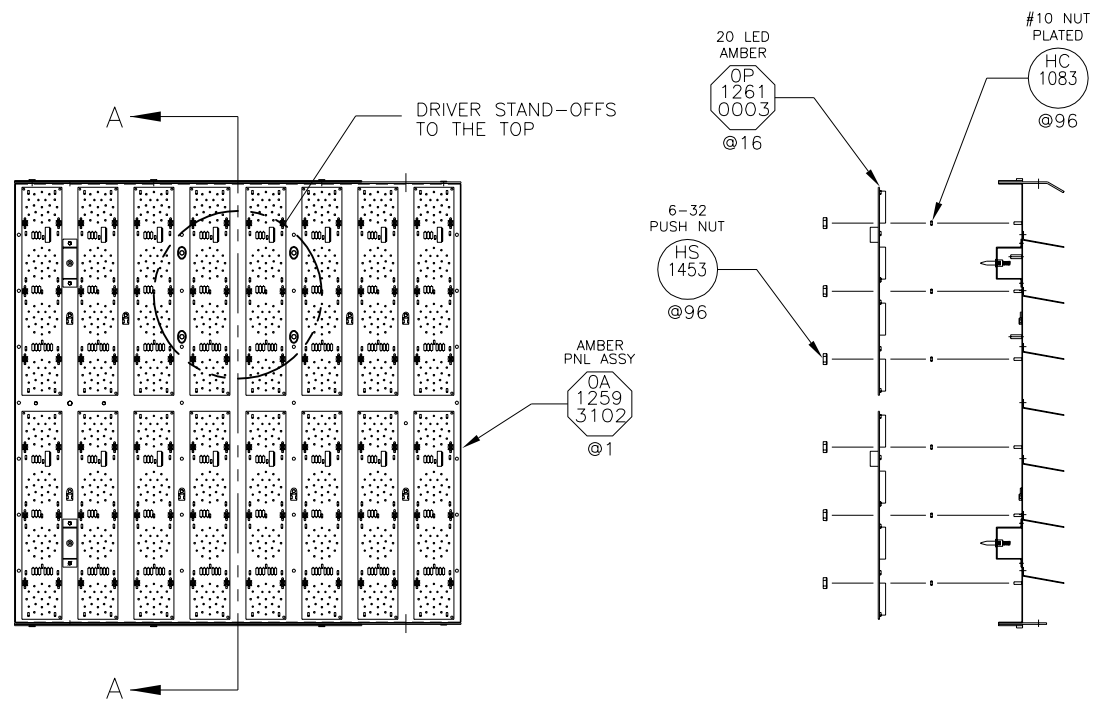

REAR VIEW

SECTION: A-A  
( SCALE 1=1 )

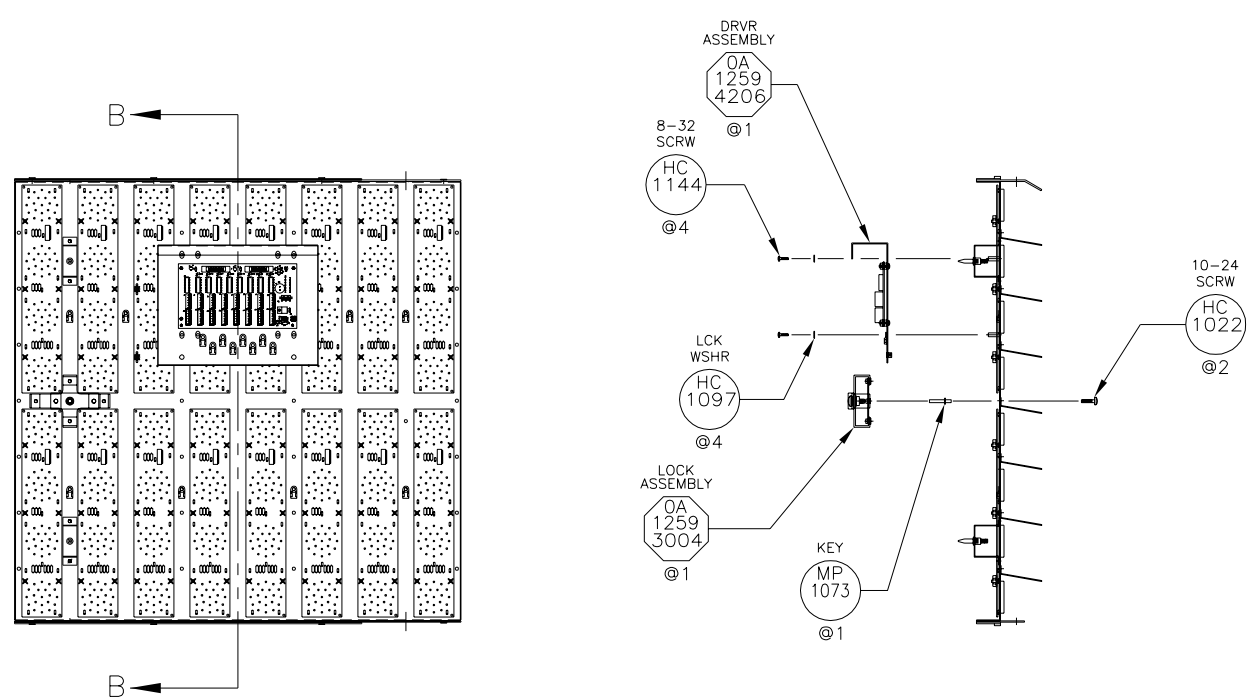

REAR VIEW

SECTION: B-B  
( SCALE 1=1 )

APPLY WEATHER STIPPING (HS-1149) TO THE OUTSIDE EDGE OF FACE PANEL AS SHOWN. TOP AND LEFT (REAR VIEW) SIDE ONLY.

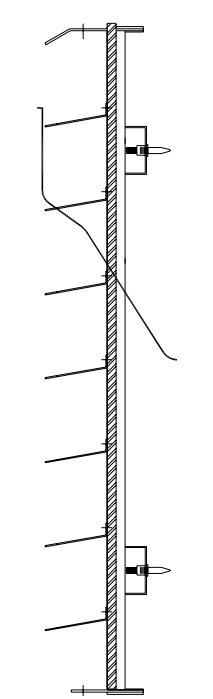

LEFT SIDE  
( NOT TO SCALE )

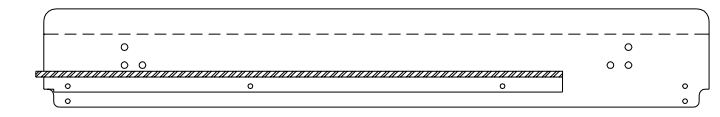

TOP VIEW  
( NOT TO SCALE )

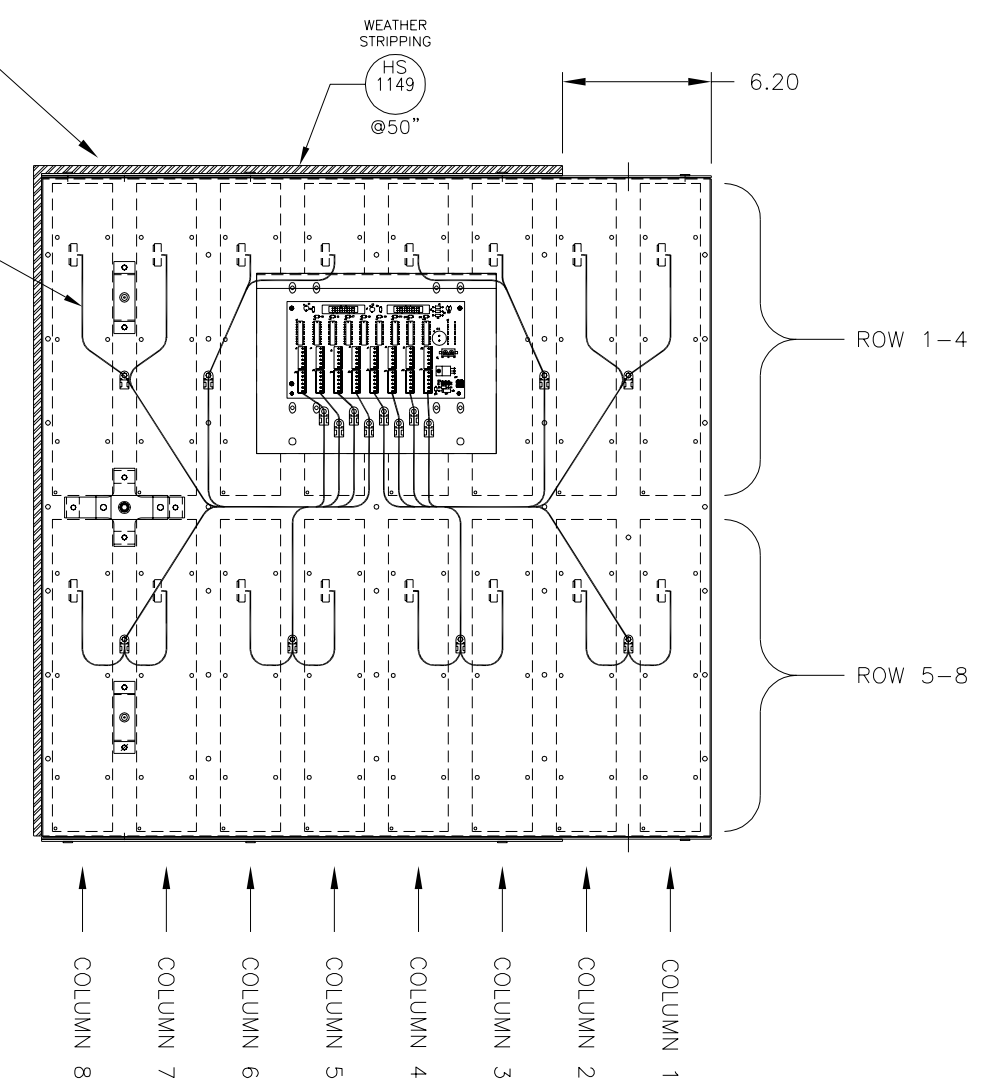

REAR VIEW  
( NOT TO SCALE )

THE CONCEPTS EXPRESSED AND DETAILS SHOWN ON THIS DRAWING ARE CONFIDENTIAL AND PROPRIETARY. DO NOT REPRODUCE BY ANY MEANS, INCLUDING ELECTRONICALLY WITHOUT THE EXPRESSED WRITTEN CONSENT OF DAKTRONICS, INC. COPYRIGHT 2002 DAKTRONICS, INC.

DAKTRONICS, INC. BROOKINGS, SD 57006	
PROJ: AF-3190 GALAXY, LARGE CHARACTER	
TITLE: MODULE PANEL , AF-3190-8X8-89MM-A	
DES. BY: JMT	DATE: 8 NOV 02
REVISION	APPR. BY:
SCALE: 1 = 12	1259-E10B-178218

REV.	DATE	DESCRIPTION	BY	APPR.

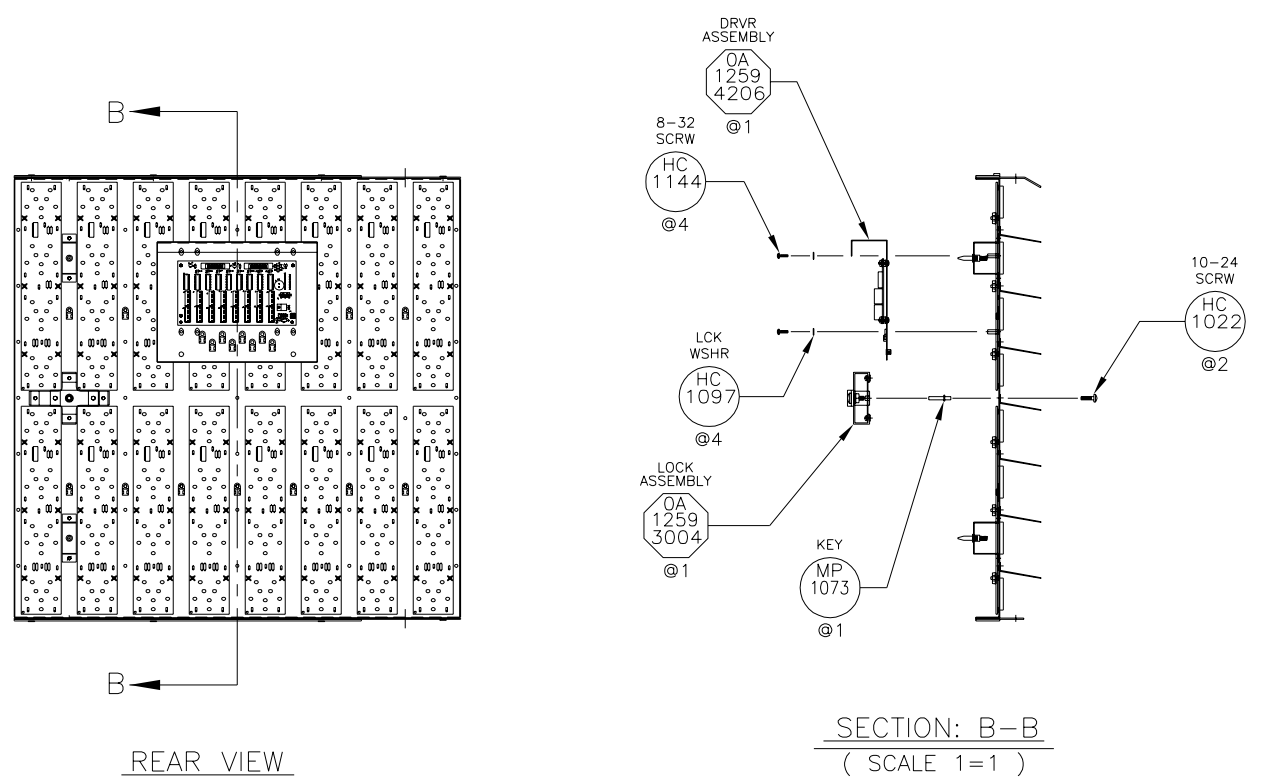
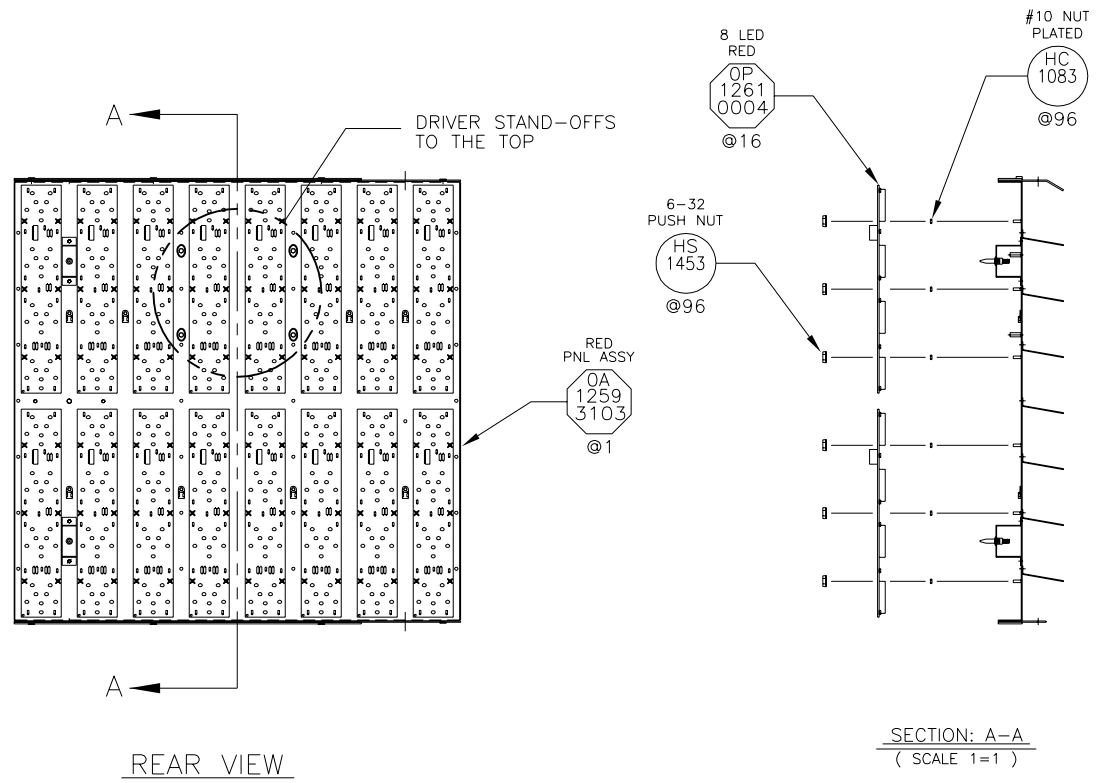

APPLY WEATHER STRIPPING  
(HS-1149) TO THE OUTSIDE EDGE  
OF FACE PANEL AS SHOWN.  
TOP AND LEFT (REAR VIEW) SIDE ONLY.

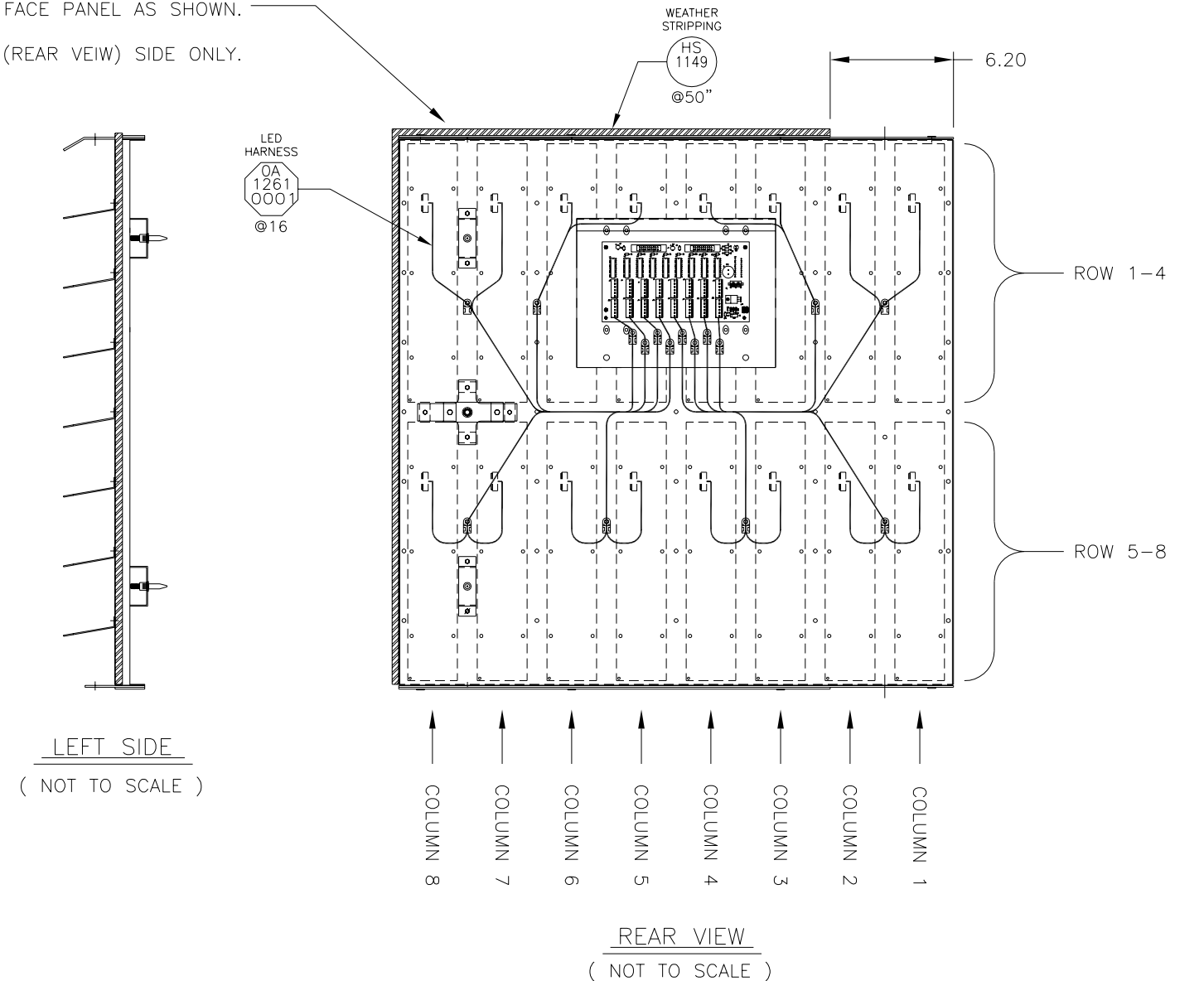

THE CONCEPTS EXPRESSED AND DETAILS SHOWN ON THIS DRAWING ARE CONFIDENTIAL AND PROPRIETARY. DO NOT REPRODUCE BY ANY MEANS, INCLUDING ELECTRONICALLY WITHOUT THE EXPRESSED WRITTEN CONSENT OF DAKTRONICS, INC. COPYRIGHT 2002 DAKTRONICS, INC.

DAKTRONICS, INC. BROOKINGS, SD 57006

PROJ: AF-3190 GALAXY, LARGE CHARACTER

TITLE: MODULE PANEL, AF-3190-8X8-89MM-R

DES. BY: JMT DRAWN BY: JMT DATE: 8 NOV 02

REVISION APPR. BY: 1259-E10B-178220

SCALE: 1 = 12

REV.	DATE	DESCRIPTION	BY	APPR.

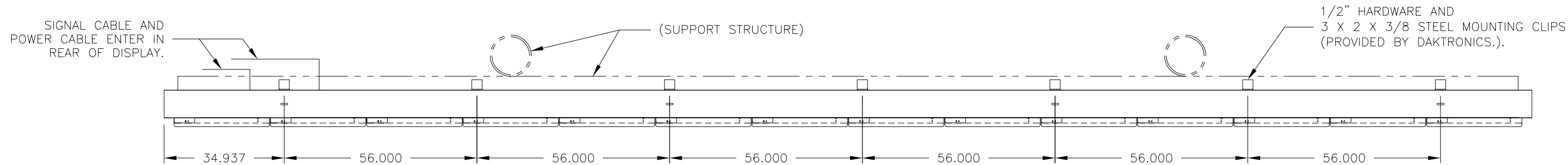

TOP VIEW

ALL SUPPORT STRUCTURE SHOWN IS FOR CONCEPT ONLY. SUPPORT STRUCTURE TO BE ENGINEERED AND BUILT BY OTHERS.

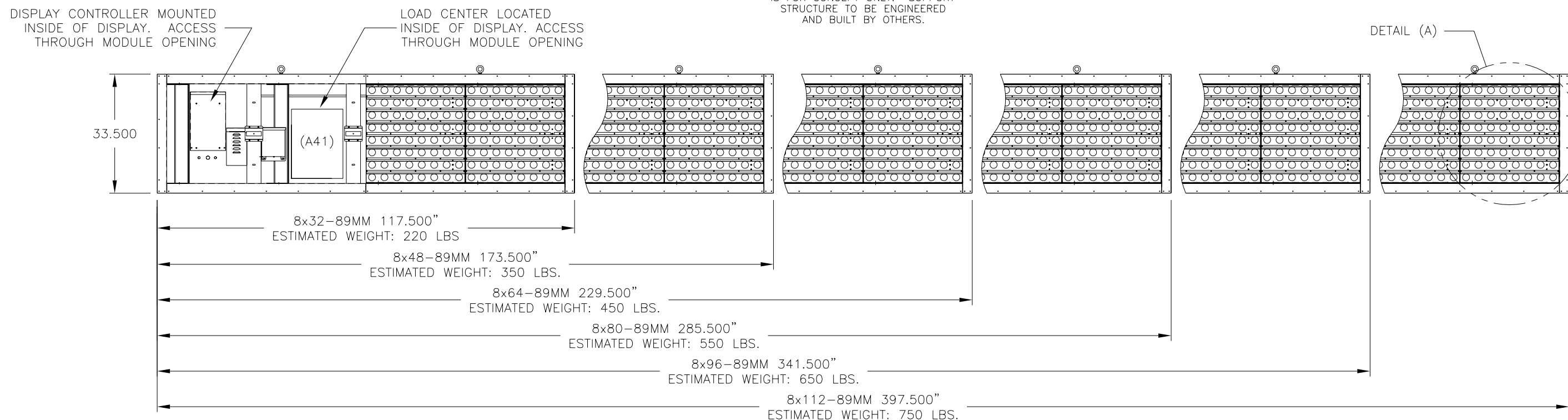

FRONT VIEW

NOTES:

- 1) ALL DIMENSIONS ARE GIVEN IN INCHES
- 2) DISPLAY IS OF ALL ALUMINUM CONSTRUCTION WITH STEEL MOUNTING CLIP ANGLES / HARDWARE.
- 3) DISPLAY IS PAINTED FLAT BLACK
- 4) SERVICE ACCESS FOR ALL DRIVERS AND ELECTRONICS IS FROM THE FRONT.
- 5) LIFT EYES WILL BE PROVIDED IN EACH SECTION FOR INSTALLATION PURPOSES. HOLES IN TOP OF THE TOP SECTIONS MUST BE FILLED AND SEALED TO PREVENT EXCESS WATER FROM ENTERING CABINET.
- 6) DISPLAY CONTROLLER AND LOAD CENTERS SUPPLIED BY DAKTRONICS AND MOUNTED INTERNALLY. SIGNAL TO BE RAN IN CONDUIT OR RACEWAY FROM COMPUTER LOCATION TO SIGNAL ENTRANCE IN BACK OF DISPLAY.
- 7) POWER CABLE / SIGNAL CABLE, ALL CONDUIT, AND ALL LABOR TO BE PROVIDED BY CUSTOMERS ELECTRICAL CONTRACTOR.
- 8) REFER TO RISER DIAGRAM FOR ELECTRICAL SPECIFICATIONS AND SIGNAL HOOK UPS.

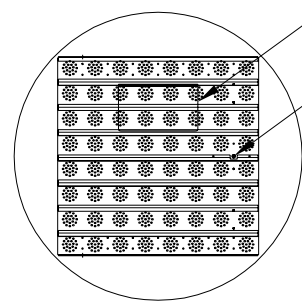

DETAIL: A  
( 8 X 8 MODULE PANEL )

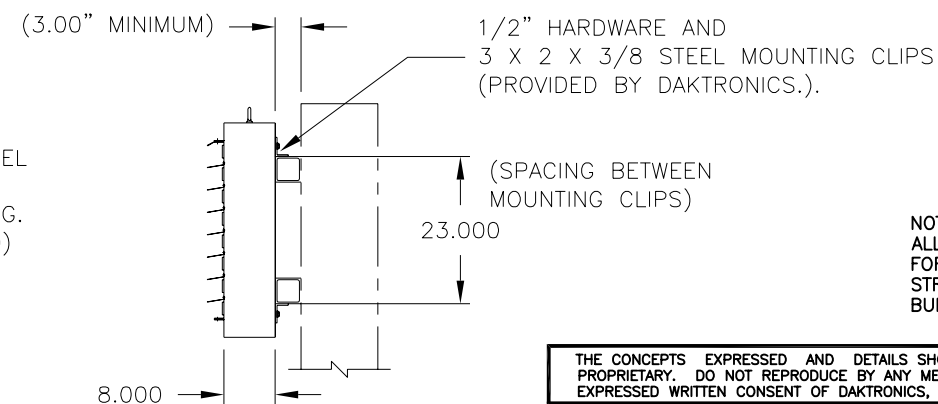

SIDE VIEW

MINIMUMS SHOWN ARE FOR VENTILATION REQUIREMENTS.

NOTE:  
ALL SUPPORT STRUCTURE SHOWN IS FOR CONCEPT ONLY. SUPPORT STRUCTURE TO BE ENGINEERED AND BUILT BY OTHERS.

THE CONCEPTS EXPRESSED AND DETAILS SHOWN ON THIS DRAWING ARE CONFIDENTIAL AND PROPRIETARY. DO NOT REPRODUCE BY ANY MEANS, INCLUDING ELECTRONICALLY WITHOUT THE EXPRESSED WRITTEN CONSENT OF DAKTRONICS, INC. COPYRIGHT 2002 DAKTRONICS, INC.

DAKTRONICS, INC. BROOKINGS, SD 57006

PROJ: AF-3190 GALAXY, LARGE CHARACTER

TITLE: SHOP DRAWING, AF-3190-8X\*\*-89MM-F

DES. BY: JMT

DRAWN BY: JMT

DATE: 12 NOV 02

REVISION

APPR. BY:

SCALE: 1 = 30

1259-E10B-178583

REV.	DATE	DESCRIPTION	BY	APPR.

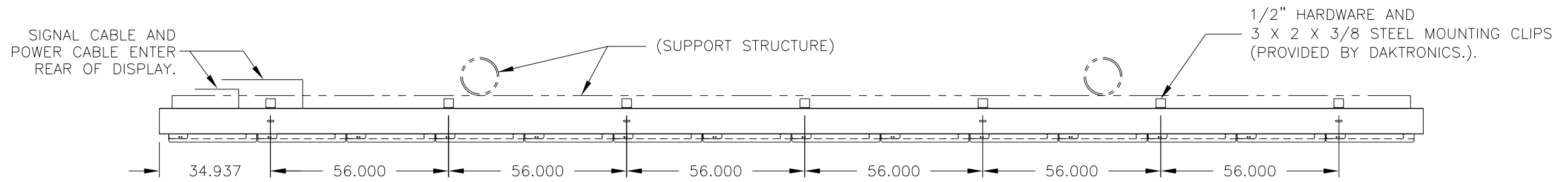

TOP VIEW  
 ALL SUPPORT STRUCTURE SHOWN IS FOR CONCEPT ONLY. SUPPORT STRUCTURE TO BE ENGINEERED AND BUILT BY OTHERS.

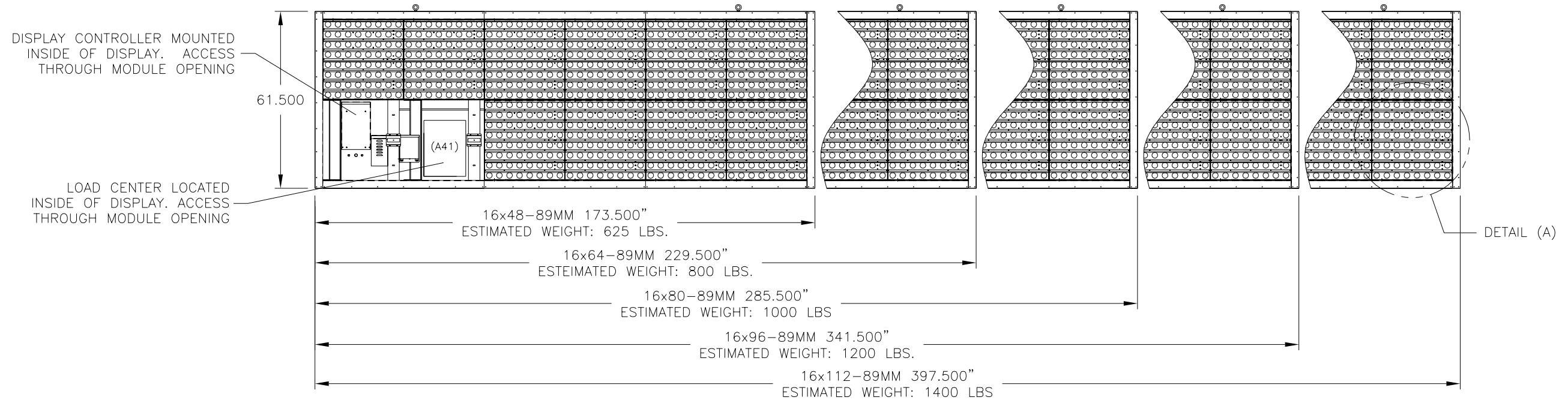

FRONT VIEW

NOTES:

- 1) ALL DIMENSIONS ARE GIVEN IN INCHES
- 2) DISPLAY IS OF ALL ALUMINUM CONSTRUCTION WITH STEEL MOUNTING CLIP ANGLES / HARDWARE.
- 3) DISPLAY IS PAINTED FLAT BLACK
- 4) SERVICE ACCESS FOR ALL DRIVERS AND ELECTRONICS IS FROM THE FRONT.
- 5) LIFT EYES WILL BE PROVIDED IN EACH SECTION FOR INSTALLATION PURPOSES. HOLES IN TOP OF THE TOP SECTIONS MUST BE FILLED AND SEALED TO PREVENT EXCESS WATER FROM ENTERING CABINET.
- 6) DISPLAY CONTROLLER AND LOAD CENTERS SUPPLIED BY DAKTRONICS AND MOUNTED INTERNALLY. SIGNAL TO BE RAN IN CONDUIT OR RACEWAY FROM COMPUTER LOCATION TO SIGNAL ENTRANCE IN BACK OF DISPLAY.
- 7) POWER CABLE / SIGNAL CABLE, ALL CONDUIT, AND ALL LABOR TO BE PROVIDED BY CUSTOMERS ELECTRICAL CONTRACTOR.
- 8) REFER TO RISER DIAGRAM FOR ELECTRICAL SPECIFICATIONS AND SIGNAL HOOK UPS.

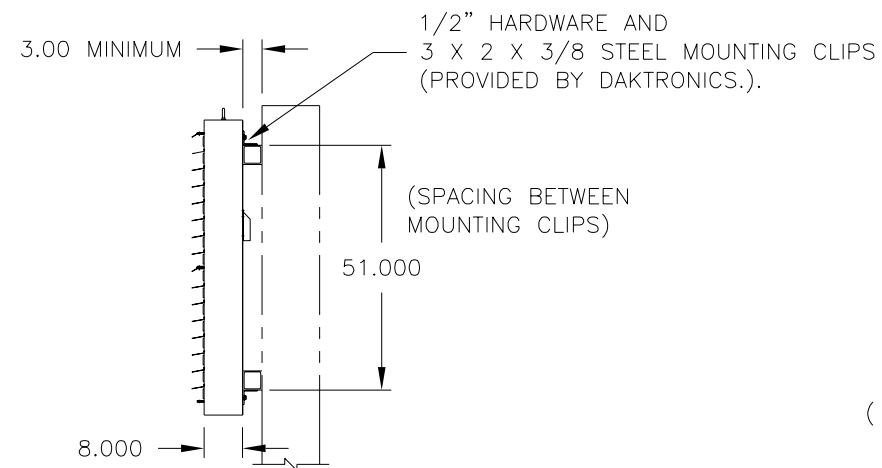

SIDE VIEW

MINIMUMS SHOWN ARE FOR VENTILATION REQUIREMENTS.

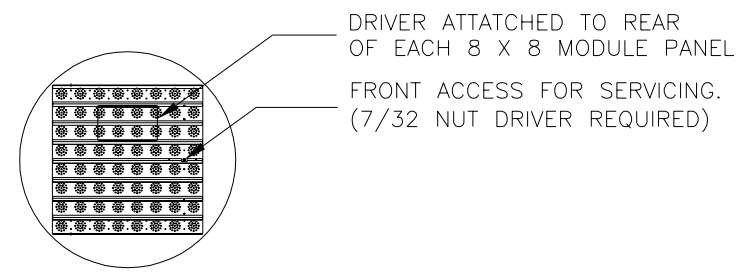

DETAIL: A  
 ( 8 X 8 MODULE PANEL )

NOTE:  
 ALL SUPPORT STRUCTURE SHOWN IS FOR CONCEPT ONLY. SUPPORT STRUCTURE TO BE ENGINEERED AND BUILT BY OTHERS.

THE CONCEPTS EXPRESSED AND DETAILS SHOWN ON THIS DRAWING ARE CONFIDENTIAL AND PROPRIETARY. DO NOT REPRODUCE BY ANY MEANS, INCLUDING ELECTRONICALLY WITHOUT THE EXPRESSED WRITTEN CONSENT OF DAKTRONICS, INC. COPYRIGHT 2002 DAKTRONICS, INC.

DAKTRONICS, INC. BROOKINGS, SD 57006	
PROJ: AF-3190 GALAXY, LARGE CHARACTER	
TITLE: SHOP DRAWING, AF-3190-16X**-89MM-F	
DES. BY: JMT	DATE: 12 NOV 02
REVISION	APPR. BY:
SCALE: 1 = 40	1259-E10B-178584

REV.	DATE	DESCRIPTION	BY	APPR.

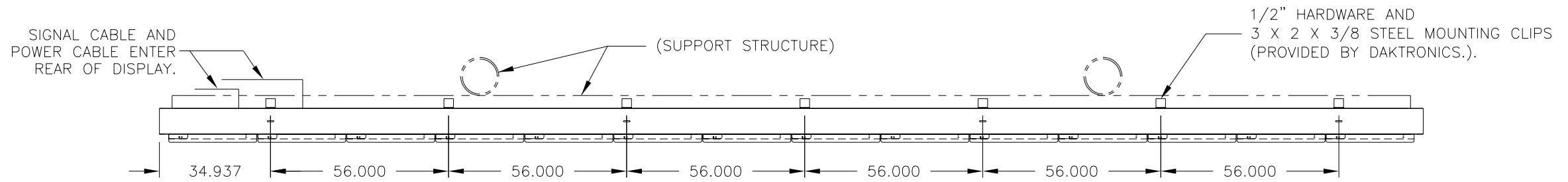

TOP VIEW

ALL SUPPORT STRUCTURE SHOWN IS FOR CONCEPT ONLY. SUPPORT STRUCTURE TO BE ENGINEERED AND BUILT BY OTHERS.

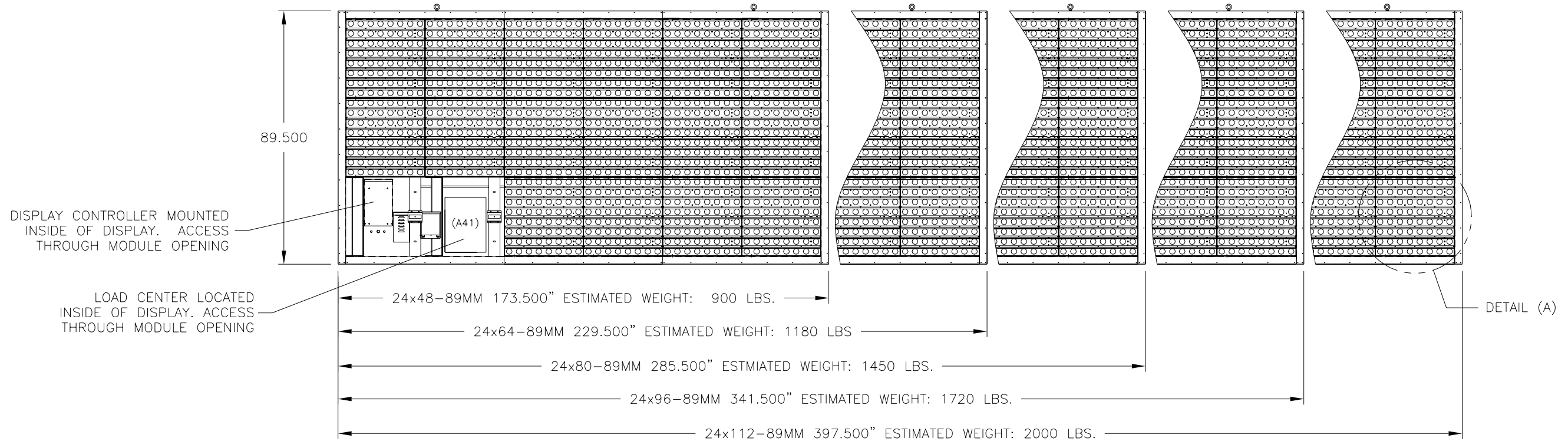

FRONT VIEW

NOTES:

- 1) ALL DIMENSIONS ARE GIVEN IN INCHES
- 2) DISPLAY IS OF ALL ALUMINUM CONSTRUCTION WITH STEEL MOUNTING CLIP ANGLES / HARDWARE.
- 3) DISPLAY IS PAINTED FLAT BLACK
- 4) SERVICE ACCESS FOR ALL DRIVERS AND ELECTRONICS IS FROM THE FRONT.
- 5) LIFT EYES WILL BE PROVIDED IN EACH SECTION FOR INSTALLATION PURPOSES. HOLES IN TOP OF THE TOP SECTIONS MUST BE FILLED AND SEALED TO PREVENT EXCESS WATER FROM ENTERING CABINET.
- 6) DISPLAY CONTROLLER AND LOAD CENTERS SUPPLIED BY DAKTRONICS AND MOUNTED INTERNALLY. SIGNAL TO BE RAN IN CONDUIT OR RACEWAY FROM COMPUTER LOCATION TO SIGNAL ENTRANCE IN BACK OF DISPLAY.
- 7) POWER CABLE / SIGNAL CABLE, ALL CONDUIT, AND ALL LABOR TO BE PROVIDED BY CUSTOMERS ELECTRICAL CONTRACTOR.
- 8) REFER TO RISER DIAGRAM FOR ELECTRICAL SPECIFICATIONS AND SIGNAL HOOK UPS.

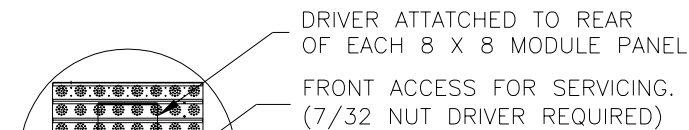
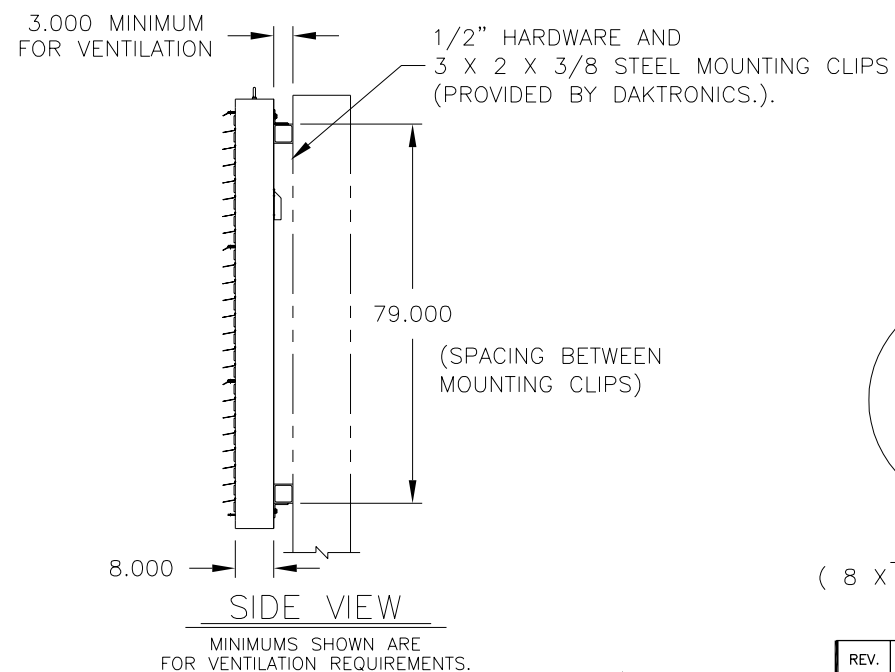

DETAIL: A  
( 8 X 8 MODULE PANEL )

NOTE:  
ALL SUPPORT STRUCTURE SHOWN IS FOR CONCEPT ONLY. SUPPORT STRUCTURE TO BE ENGINEERED AND BUILT BY OTHERS.

THE CONCEPTS EXPRESSED AND DETAILS SHOWN ON THIS DRAWING ARE CONFIDENTIAL AND PROPRIETARY. DO NOT REPRODUCE BY ANY MEANS, INCLUDING ELECTRONICALLY WITHOUT THE EXPRESSED WRITTEN CONSENT OF DAKTRONICS, INC. COPYRIGHT 2002 DAKTRONICS, INC.

DAKTRONICS, INC. BROOKINGS, SD 57006

PROJ: AF-3190 GALAXY, LARGE CHARACTER

TITLE: SHOP DRAWING, AF-3190-24X\*\*-89MM-F

DES. BY: JMT

DRAWN BY: JMT

DATE: 12 NOV 02

REVISION

APPR. BY:

SCALE: 1 = 40

1259-E10B-178585

REV.	DATE	DESCRIPTION	BY	APPR.

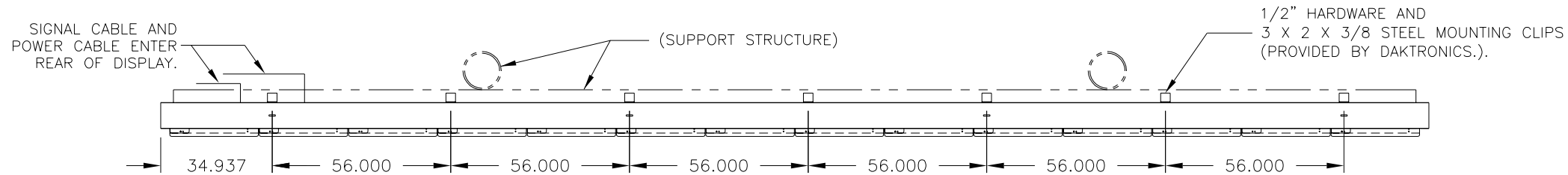

TOP VIEW

ALL SUPPORT STRUCTURE SHOWN IS FOR CONCEPT ONLY. SUPPORT STRUCTURE TO BE ENGINEERED AND BUILT BY OTHERS.

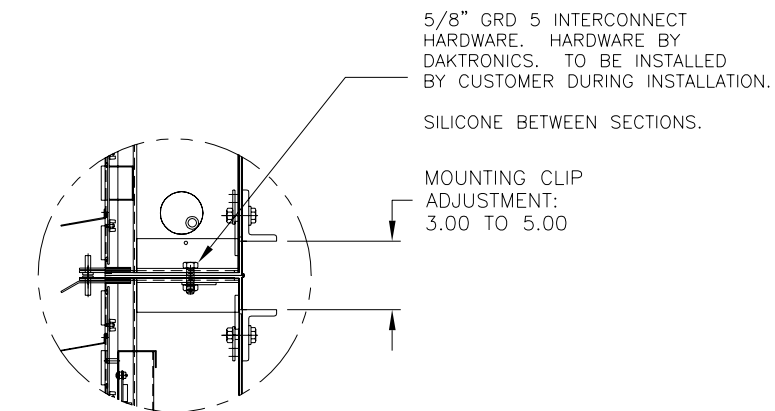

DETAIL: B ( NOT TO SCALE )

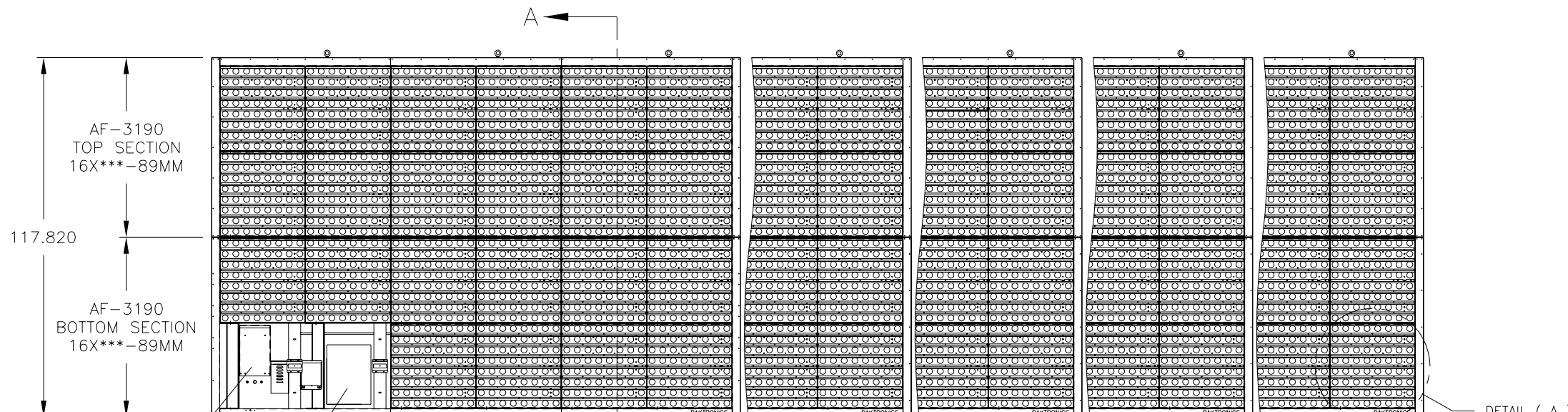

FRONT VIEW

DISPLAY CONTROLLER MOUNTED INSIDE OF DISPLAY. ACCESS THROUGH MODULE OPENING

LOAD CENTER LOCATED INSIDE OF DISPLAY. ACCESS THROUGH MODULE OPENING

- 32x48-89MM 173.500" ESTIMATED WEIGHT: 1150 LBS.
- 32x64-89MM 229.500" ESTIMATED WEIGHT: 1520 LBS.
- 32x80-89MM 285.500" ESTIMATED WEIGHT: 1900 LBS.
- 32x96-89MM 341.500" ESTIMATED WEIGHT: 2250 LBS.
- 32x112-89MM 397.500" ESTIMATED WEIGHT: 2629 LBS.

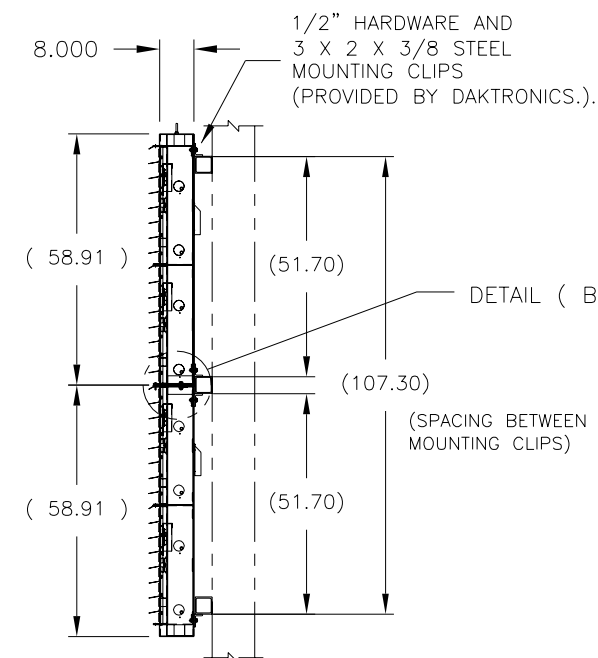

SECTION: A-A ( 1 X SCALE )

ALL SUPPORT STRUCTURE SHOWN IS FOR CONCEPT ONLY. SUPPORT STRUCTURE TO BE ENGINEERED AND BUILT BY OTHERS.

NOTES:

- 1) ALL DIMENSIONS ARE GIVEN IN INCHES
- 2) DISPLAY IS OF ALL ALUMINUM CONSTRUCTION WITH STEEL MOUNTING CLIP ANGLES / HARDWARE.
- 3) DISPLAY IS PAINTED FLAT BLACK
- 4) SERVICE ACCESS FOR ALL DRIVERS AND ELECTRONICS IS FROM THE FRONT.
- 5) LIFT EYES WILL BE PROVIDED IN EACH DISPLAY FOR INSTALLATION PURPOSES. HOLES IN THE TOP OF EACH DISPLAY MUST BE FILLED AND SEALED TO PREVENT EXCESS WATER FROM ENTERING CABINET.

NOTES CONTINUED:

- 6) DISPLAY CONTROLLER AND LOAD CENTERS SUPPLIED BY DAKTRONICS AND MOUNTED INTERNALLY. SIGNAL TO BE RAN IN CONDUIT OR RACEWAY FROM COMPUTER LOCATION TO SIGNAL ENTRANCE IN BACK OF DISPLAY.
- 7) POWER CABLE / SIGNAL CABLE, ALL CONDUIT, AND ALL LABOR TO BE PROVIDED BY CUSTOMERS ELECTRICAL CONTRACTOR.
- 8) REFER TO RISER DIAGRAM FOR ELECTRICAL SPECIFICATIONS AND SIGNAL HOOK UPS.

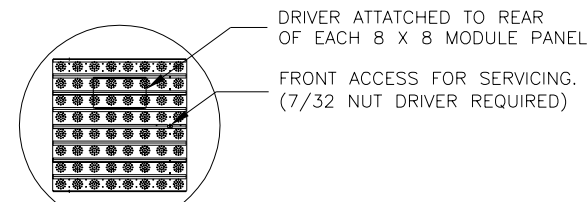

DETAIL: A ( 8 X 8 MODULE PANEL )

THE CONCEPTS EXPRESSED AND DETAILS SHOWN ON THIS DRAWING ARE CONFIDENTIAL AND PROPRIETARY. DO NOT REPRODUCE BY ANY MEANS, INCLUDING ELECTRONICALLY WITHOUT THE EXPRESSED WRITTEN CONSENT OF DAKTRONICS, INC. COPYRIGHT 2002 DAKTRONICS, INC.

DAKTRONICS, INC. BROOKINGS, SD 57006

PROJ: AF-3190 GALAXY, LARGE CHARACTER

TITLE: SHOP DRAWING, AF-3190-32x\*\*\*-89MM-F

DES. BY: JMT

DRAWN BY: JMT

DATE: 12 NOV 02

REVISION

APPR. BY:

SCALE: 1 = 45

1259-E10B-178586

REV.	DATE	DESCRIPTION	BY	APPR.

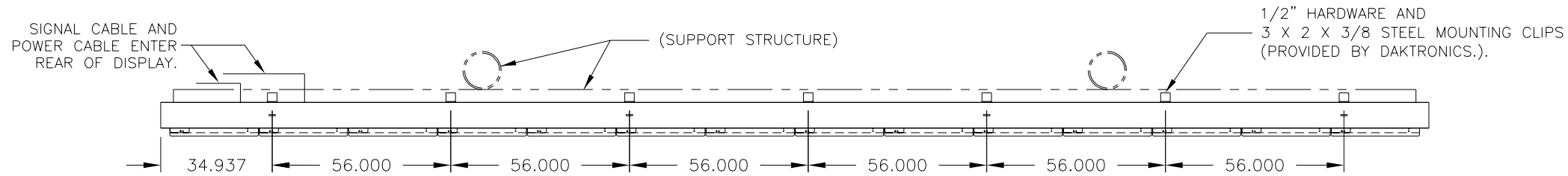

**TOP VIEW**  
ALL SUPPORT STRUCTURE SHOWN IS FOR CONCEPT ONLY. SUPPORT STRUCTURE TO BE ENGINEERED AND BUILT BY OTHERS.

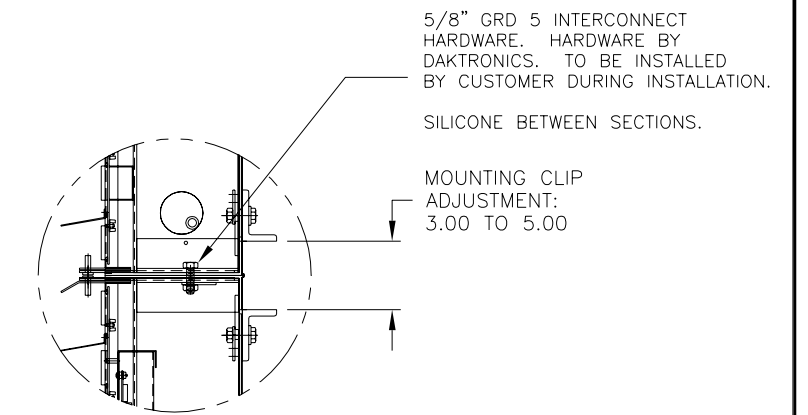

**DETAIL: B**  
( NOT TO SCALE )

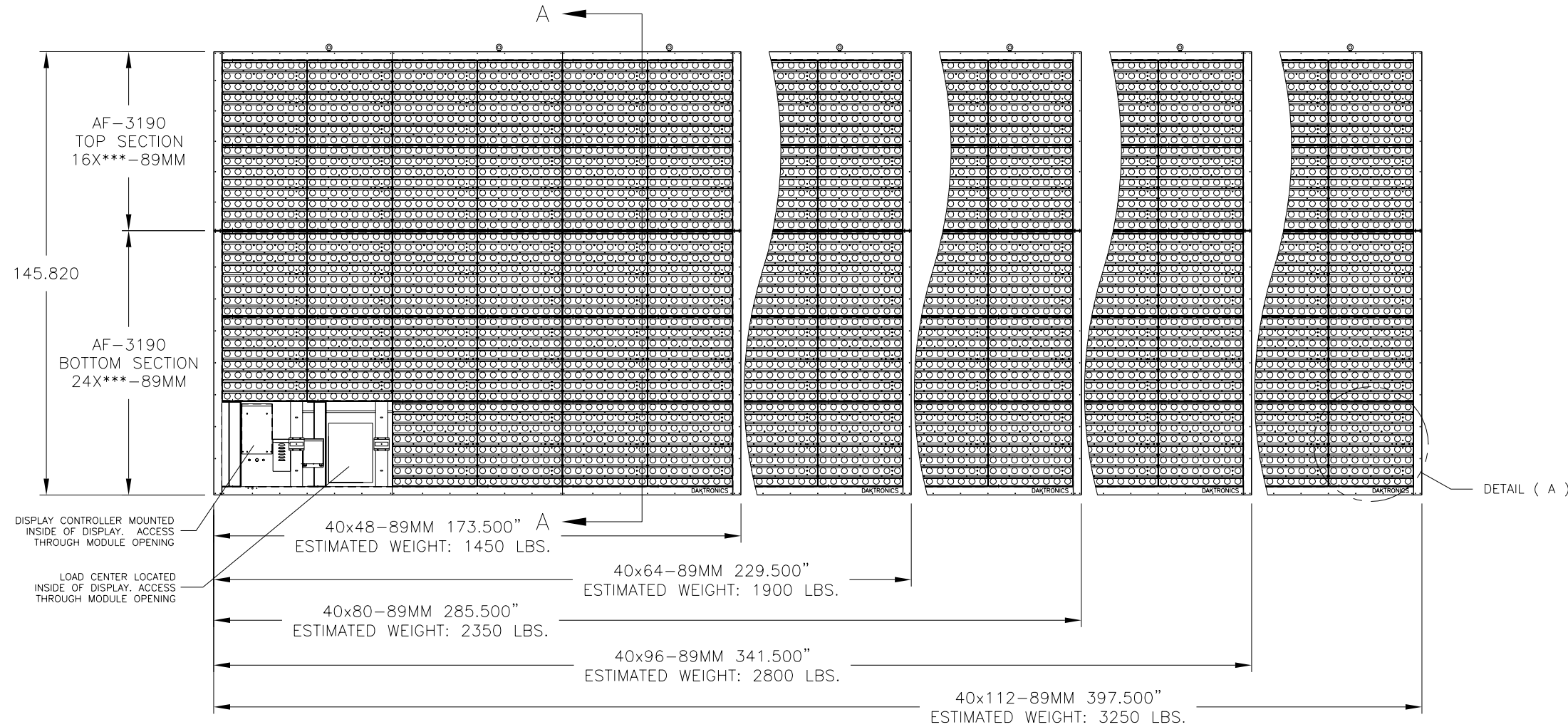

**FRONT VIEW**

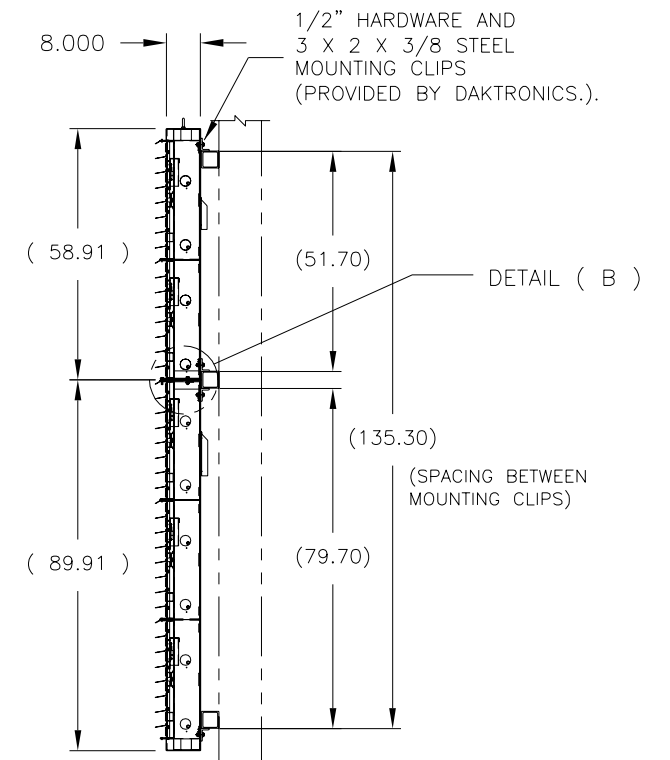

**SECTION: A-A**  
( 1 X SCALE )

ALL SUPPORT STRUCTURE SHOWN IS FOR CONCEPT ONLY. SUPPORT STRUCTURE TO BE ENGINEERED AND BUILT BY OTHERS.

- NOTES:
- 1) ALL DIMENSIONS ARE GIVEN IN INCHES
  - 2) DISPLAY IS OF ALL ALUMINUM CONSTRUCTION WITH STEEL MOUNTING CLIP ANGLES / HARDWARE.
  - 3) DISPLAY IS PAINTED FLAT BLACK
  - 4) SERVICE ACCESS FOR ALL DRIVERS AND ELECTRONICS IS FROM THE FRONT.
  - 5) LIFT EYES WILL BE PROVIDED IN EACH DISPLAY FOR INSTALLATION PURPOSES. HOLES IN THE TOP OF EACH DISPLAY MUST BE FILLED AND SEALED TO PREVENT EXCESS WATER FROM ENTERING CABINET.

- NOTES CONTINUED:
- 6) DISPLAY CONTROLLER AND LOAD CENTERS SUPPLIED BY DAKTRONICS AND MOUNTED INTERNALLY. SIGNAL TO BE RAN IN CONDUIT OR RACEWAY FROM COMPUTER LOCATION TO SIGNAL ENTRANCE IN BACK OF DISPLAY.
  - 7) POWER CABLE / SIGNAL CABLE, ALL CONDUIT, AND ALL LABOR TO BE PROVIDED BY CUSTOMERS ELECTRICAL CONTRACTOR.
  - 8) REFER TO RISER DIAGRAM FOR ELECTRICAL SPECIFICATIONS AND SIGNAL HOOK UPS.

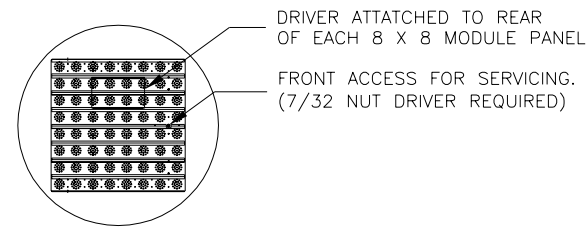

**DETAIL: A**  
( 8 X 8 MODULE PANEL )

THE CONCEPTS EXPRESSED AND DETAILS SHOWN ON THIS DRAWING ARE CONFIDENTIAL AND PROPRIETARY. DO NOT REPRODUCE BY ANY MEANS, INCLUDING ELECTRONICALLY WITHOUT THE EXPRESSED WRITTEN CONSENT OF DAKTRONICS, INC. COPYRIGHT 2002 DAKTRONICS, INC.

DAKTRONICS, INC. BROOKINGS, SD 57006

PROJ: AF-3190 GALAXY, LARGE CHARACTER

TITLE: SHOP DRAWING, AF-3190-40x\*\*\*-89MM-F

DES. BY: JMT

DRAWN BY: JMT

DATE: 12 NOV 02

REVISION

APPR. BY:

SCALE: 1 = 45

1259-E10B-178587

REV.	DATE	DESCRIPTION	BY	APPR.



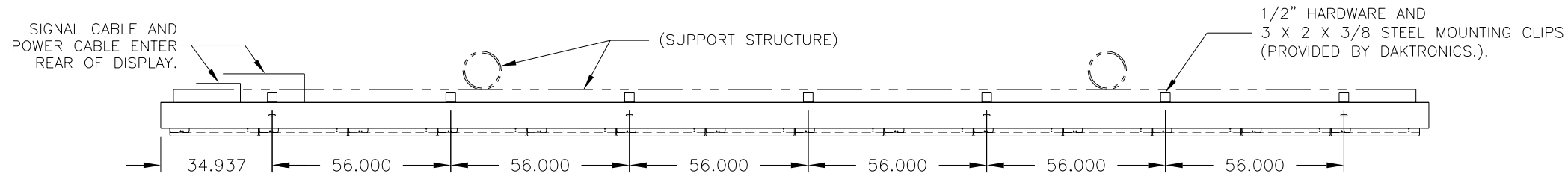

TOP VIEW

ALL SUPPORT STRUCTURE SHOWN IS FOR CONCEPT ONLY. SUPPORT STRUCTURE TO BE ENGINEERED AND BUILT BY OTHERS.

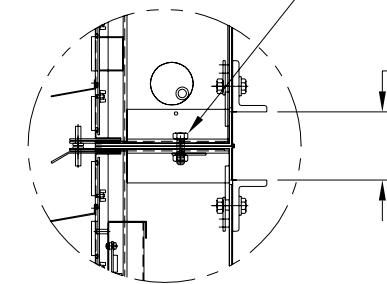

DETAIL: B  
( NOT TO SCALE )

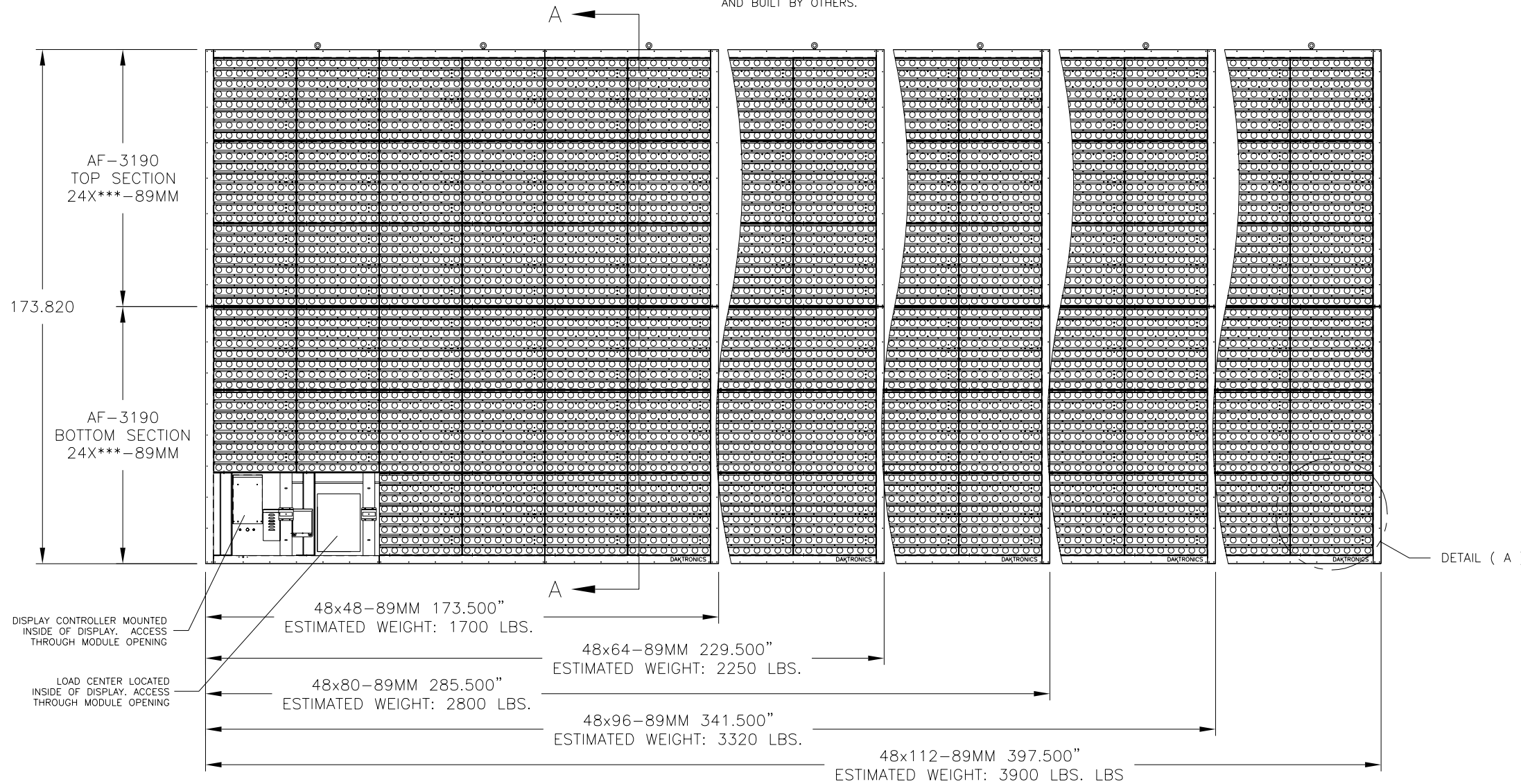

FRONT VIEW

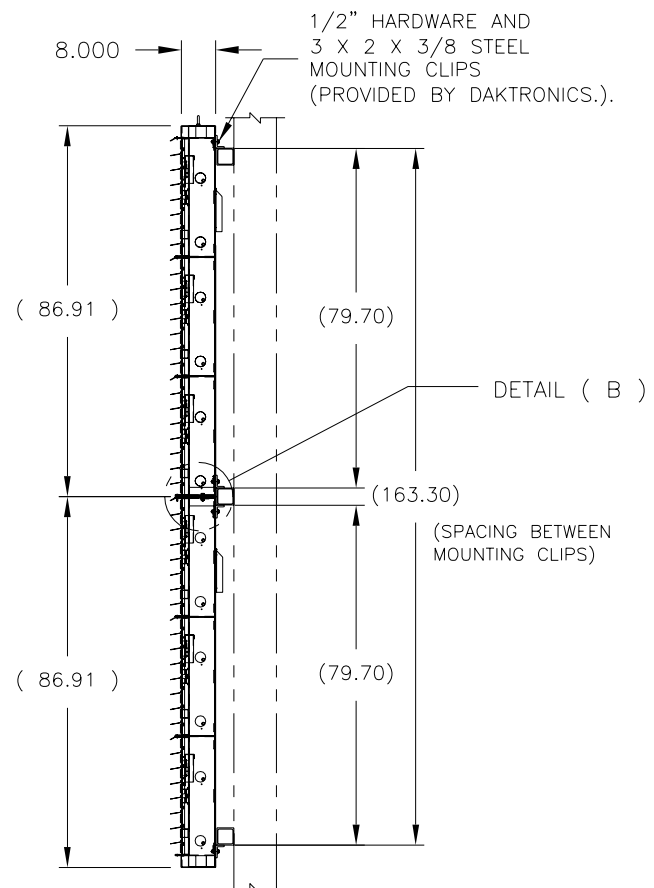

SECTION: A-A  
( 1 X SCALE )

ALL SUPPORT STRUCTURE SHOWN IS FOR CONCEPT ONLY. SUPPORT STRUCTURE TO BE ENGINEERED AND BUILT BY OTHERS.

NOTES:

- 1) ALL DIMENSIONS ARE GIVEN IN INCHES
- 2) DISPLAY IS OF ALL ALUMINUM CONSTRUCTION WITH STEEL MOUNTING CLIP ANGLES / HARDWARE.
- 3) DISPLAY IS PAINTED FLAT BLACK
- 4) SERVICE ACCESS FOR ALL DRIVERS AND ELECTRONICS IS FROM THE FRONT.
- 5) LIFT EYES WILL BE PROVIDED IN EACH DISPLAY FOR INSTALLATION PURPOSES. HOLES IN THE TOP OF EACH DISPLAY MUST BE FILLED AND SEALED TO PREVENT EXCESS WATER FROM ENTERING CABINET.

NOTES CONTINUED:

- 6) DISPLAY CONTROLLER AND LOAD CENTERS SUPPLIED BY DAKTRONICS AND MOUNTED INTERNALLY. SIGNAL TO BE RAN IN CONDUIT OR RACEWAY FROM COMPUTER LOCATION TO SIGNAL ENTRANCE IN BACK OF DISPLAY.
- 7) POWER CABLE / SIGNAL CABLE, ALL CONDUIT, AND ALL LABOR TO BE PROVIDED BY CUSTOMERS ELECTRICAL CONTRACTOR.
- 8) REFER TO RISER DIAGRAM FOR ELECTRICAL SPECIFICATIONS AND SIGNAL HOOK UPS.

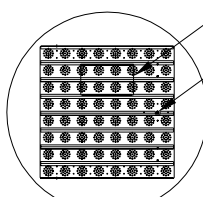

DETAIL: A  
( 8 X 8 MODULE PANEL )

THE CONCEPTS EXPRESSED AND DETAILS SHOWN ON THIS DRAWING ARE CONFIDENTIAL AND PROPRIETARY. DO NOT REPRODUCE BY ANY MEANS, INCLUDING ELECTRONICALLY WITHOUT THE EXPRESSED WRITTEN CONSENT OF DAKTRONICS, INC. COPYRIGHT 2002 DAKTRONICS, INC.

DAKTRONICS, INC. BROOKINGS, SD 57006

PROJ: AF-3190 GALAXY, LARGE CHARACTER

TITLE: SHOP DRAWING, AF-3190-48x\*\*\*-89MM-F

DES. BY: JMT

DRAWN BY: JMT

DATE: 12 NOV 02

REVISION

APPR. BY:

SCALE: 1 = 45

1259-E10B-178588

REV.	DATE	DESCRIPTION	BY	APPR.

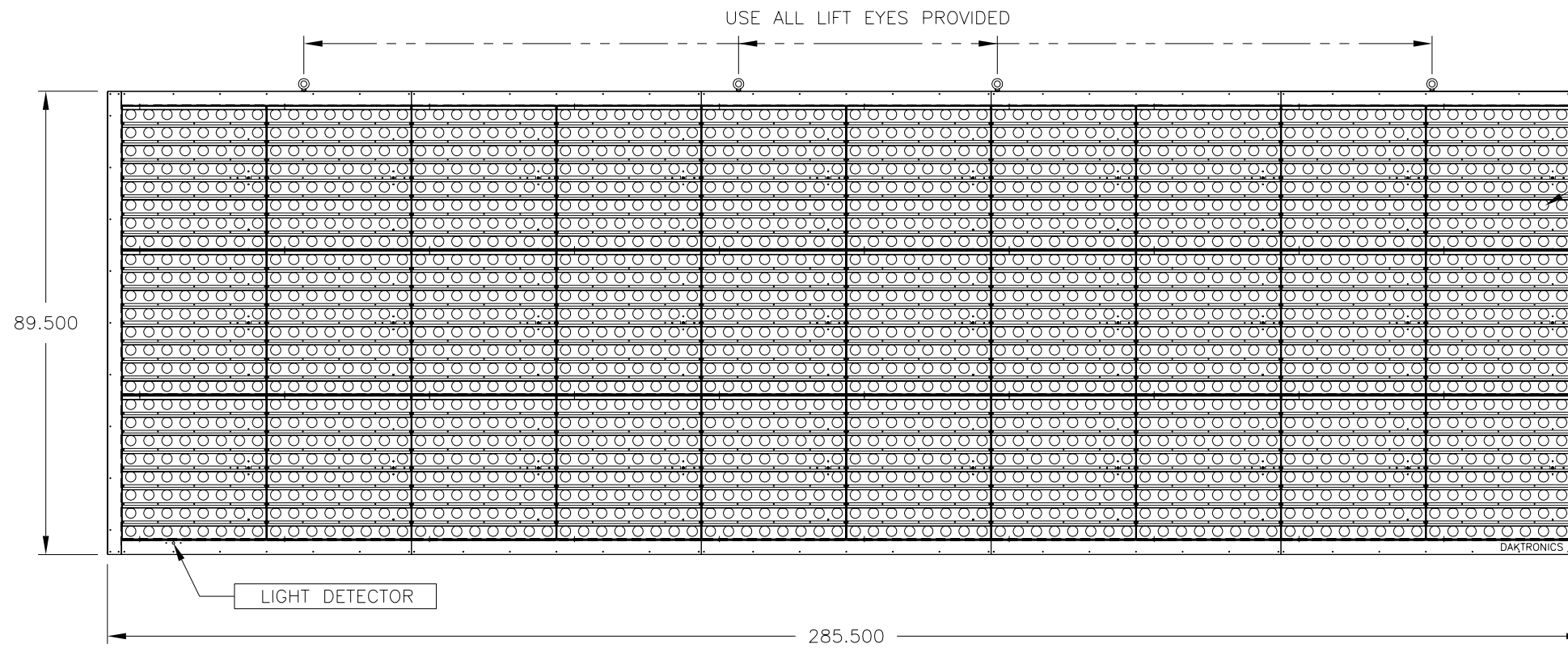

FRONT VIEW  
(SHOWN WITH MODULE PANELS)

FACE PANEL ASSY.

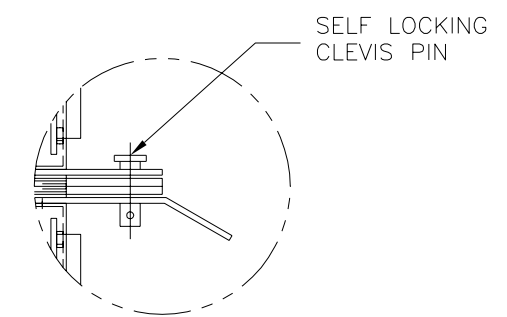

DETAIL: A  
(NOT TO SCALE)

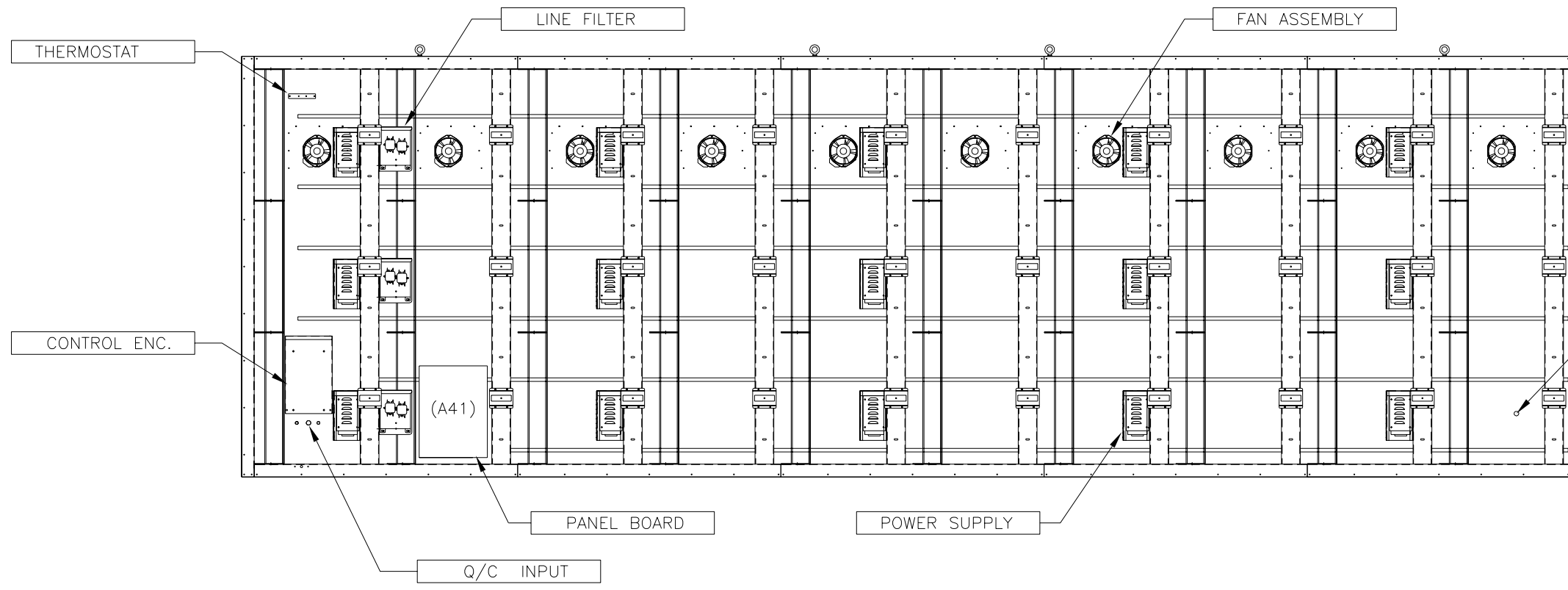

FRONT VIEW  
(SHOWN WITHOUT MODULE PANELS)

THE CONCEPTS EXPRESSED AND DETAILS SHOWN ON THIS DRAWING ARE CONFIDENTIAL AND PROPRIETARY. DO NOT REPRODUCE BY ANY MEANS, INCLUDING ELECTRONICALLY WITHOUT THE EXPRESSED WRITTEN CONSENT OF DAKTRONICS, INC. COPYRIGHT 2002 DAKTRONICS, INC.

DAKTRONICS, INC. BROOKINGS, SD 57006

PROJ: AF-3400 GALAXY LARGE CHARACTER

TITLE: COMPONENT LAYOUT, AF-3400-\*\*X\*\*-89MM

DES. BY: JMT DRAWN BY: JMT DATE: 15 JAN 03

REV.	DATE	DESCRIPTION	BY	APPR.
01	14JUN05	UPDATED NOMENCLATURE	JTELLIN	

REVISION	APPR. BY:	1259-E10B-181666
01	SCALE: 1=30	