

**Petroleum Price Displays
DF-2000 Series (10"-24")**

Installation and Operation Manual

ED-16167

Rev 4

4 September 2007

DAKTRONICS

Website: www.daktronics.com
Tel: 866-343-3122 Fax: 605-697-4444
331 32nd Ave, PO Box 5128, Brookings SD 57006



*Please fill in the information below for your DataMaster display and controller;
use it for reference when calling Daktronics for assistance.*

Display Serial No. _____

Display Model No. _____

Date Installed _____

DataMaster Serial No. _____

DAKTRONICS, INC.

Copyright © 2006-2007

All rights reserved. While every precaution has been taken in the preparation of this manual, the publisher assumes no responsibility for errors or omissions. No part of this book covered by the copyrights here on may be reproduced or copied in any form or by any means – graphic, electronic, or mechanical, including photocopying, taping, or information storage and retrieval systems – without written permission of the publisher.

DataMaster™ and DataTime® are trademarks of Daktronics, Inc. Other trademarks used in this manual are the property of their respective owners.

Table of Contents

Section 1:	Introduction.....	1
1.1	Product Overview.....	1
1.2	Model and Label Information.....	2
Section 2:	Mechanical Installation.....	3
2.1	Shop Drawings.....	3
2.2	Specifications.....	4
2.3	Lifting the Display.....	5
Section 3:	Electrical Installation.....	7
3.1	Power installation.....	8
	Grounding.....	8
	Power Disconnect.....	9
	Power Installation.....	9
3.2	Signal Connection.....	10
	LED Drivers.....	10
	Signal Wiring.....	10
	Address Dip Switch Settings.....	10
3.3	Power Up Self-test.....	11
Section 4:	Troubleshooting and Parts Replacement.....	13
4.1	Component Location and Access.....	13
4.2	Diagnostics.....	14
	Driver LEDs.....	14
	Power On Self-test.....	14
4.3	Troubleshooting.....	15
4.4	Parts Replacement.....	16
4.5	Instructions for Replacing Parts.....	18
	Replacing a Digit Panel.....	18
	Replacing a Digit Segment.....	19
	Replacing a Driver.....	19
4.6	Daktronics Exchange and Repair & Return Programs.....	20
	Exchange Program.....	20
4.7	Repair & Return Program.....	21
Section 5:	DM-100 Controller.....	23
5.1	DataMaster 100 Overview.....	23
	Replacement Parts List.....	23
5.2	Connecting the DM-100 to the Display.....	24

5.3	DataMaster Insert and Code.....	25
5.4	Petroleum Price Display Operation.....	25
	Petroleum Price Display Startup	25
	Petroleum Price Controller Operation.....	26
	Modifying Price Line Settings.....	26
	Menu Items	27
	Modem Settings.....	28
	Display Status.....	28
	Set Time.....	30
	Dimming	31
	Update Display	32
Section 6:	RC-50 Controller	33
6.1	Petroleum Price Display Operation.....	33
	Editing the Display	33
Section 7:	RC-100 Controller	35
7.1	Petroleum Price Display Operation.....	35
	Petroleum Price Display Startup	35
	Petroleum Price Controller Operation.....	36
	Modifying Price Line Settings.....	36
	Dimming	37
Section 8:	POS Interface Installation and Operation.....	39
8.1	Installation Preparation.....	39
8.2	Hardware installation:.....	39
8.3	Configuring the DM-100 for Gilbarco G-Site Interface.....	40
	Preparation	40
	Configuration	40
8.4	Configuring the DM-100 for Allied Interface.....	41
	Preparation	41
	Configuration	41
8.5	Configuring the DM-100 for PAM 1000 Interface	42
	Preparation	42
	Configuration	42
8.6	Changing Prices:.....	43
Appendix A:	Reference Drawings	45

List of Figures

Figure 1: DF-2000 Petroleum Price Display.....	1
Figure 2: Sign with Digit Displays.....	1
Figure 3: Display Identification Label	2
Figure 4: Lifting the Display	5
Figure 4: Installation Overview	7
Figure 6: Power Pigtail Wiring	9
Figure 7: Driver.....	10
Figure 8: DIP Switches	10
Figure 9: DF-2000, Front View with Face Panels Open.....	13
Figure 10: Driver Diagnostics	14
Figure 11: Digit Panel Assembly	18
Figure 12: Segmented Digit.....	19
Figure 13: Driver Board	19
Figure 14: DataMaster 100.....	23
Figure 15: Wire Control Outdoors	24
Figure 16: Wire Control from Building Location	24
Figure 17: DM-100 Insert.....	25
Figure 18: RC-50 Controller	33
Figure 19: RC-100 Controller	35

Section 1: Introduction

This manual explains the installation and operation of Daktronics DataMaster™ Outdoor LED Petroleum Price Displays. If questions arise regarding the safety, installation, operation, or service of these systems, use the Daktronics contact information listed on the cover page of this manual.

1.1 Product Overview

DataMaster Petroleum Price displays are part of a family of Daktronics products designed for easy installation, readability, and reliability. Microprocessor control assures consistent operation and accuracy.

The DataMaster Series includes standard petroleum price displays in the US employing a 9/10 fraction (**Figure 1**). The displays feature highly visible PanaView® digits in a variety of heights. Power usage for individual displays in this series is a maximum 150 W. All models have an option of 120 V or 240 V.

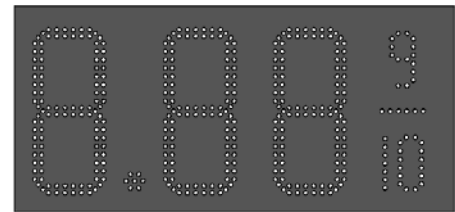

Figure 1: DF-2000 Petroleum Price Display

The Petroleum Price displays are available in two model types, a full-cabinet model designed for stand-alone use (DF-2000-SF), and a front-insertion, or “drop-in” model designed for installation in an existing or custom sign (DF-2000-DI). Refer to **Drawing A-308916** for the current drop-in models. DataMaster cabinets, specially developed for outdoor use, are constructed of heavy-gauge aluminum. Mounting weights and dimensions for each model are listed in **Section 2** of this manual.

DataMaster displays use light emitting diodes to illuminate their numeric digits. LEDs are high-intensity, low-energy lighting units that use a semiconductor to transform electrical current into light. All DataMaster displays are configured with red, amber or green LEDs. Because of their LED technology, the displays consume little power, some barely more than a household lamp.

The DataMaster outdoor LED displays have been designed for use with a DataMaster™ 100 hand-held controller, a radio-controlled RC-100 system, or the RC-50 mini remote control. All controller devices use a keyboard overlay (called an insert) for display control.

In this manual, the complete structure will be referred to as a "sign". Each sign typically consists of a number of digit displays. Refer to **Figure 2**.

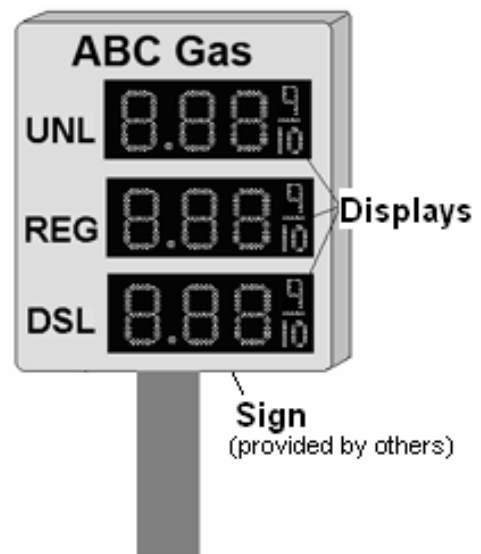

Figure 2: Sign with Digit Displays

1.2 Model and Label Information

A DataMaster model number is described in the following example:

DF-2000-13-A-SF		
DF-2000	=	Outdoor digit display
13	=	Digit height in inches (13, 18, 24, 36 and 48)
A	=	LED Color- A (Amber) or R (Red), G (Green)
SF		Single face

The serial and model numbers of a Daktronics display can be found on the ID label on the display. The label will be similar to the one shown in **Figure 2**. When calling Daktronics Customer Service, please have this information available to ensure that your request is serviced as quickly as possible. For future reference, note your display model number, serial number, and installation date on the front page of this manual.

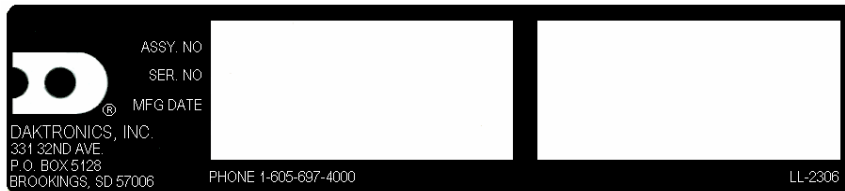

Figure 3: Display Identification Label

Section 2: Mechanical Installation



Important Safeguards:

- Read and understand these instructions before installing your display.
- Do not drop the controller or allow it to get wet.
- Properly ground the display with a ground rod at the sign location.
- **Disconnect power when the display is not in use.**
- **Disconnect power when servicing the display.**
- Do not modify the display structure or attach any panels or coverings without the express written consent of Daktronics, Inc.

2.1 Shop Drawings

Use the following table to determine the mechanical specifications for your display. The drawings are listed below by model number and are included in **Appendix A**.

Single-faced displays	
Drawing Title	Drawing Number
Shop Drawing, DF-2000-10-X-NA-SF	Drawing B-295518
Shop Drawing, DF-2000-13-X-NA-SF	Drawing B-294987
Shop Drawing, DF-2000-18-X-NA-SF	Drawing B-295355
Shop Drawing, DF-2000-24-X-NA-SF	Drawing B-295722
Drop-in displays	
Drawing Title	Drawing Number
Shop Drawing, DF-2000-10-X-NA-DI	Drawing B-294457
Shop Drawing, DF-2000-13-X-NA-DI	Drawing B-294734
Shop Drawing, DF-2000-18-X-NA-DI	Drawing B-294758
Shop Drawing, DF-2000-24-X-NA-DI	Drawing B-294487

2.2 Specifications

The table below shows all of the mechanical specifications, circuit specifications, and maximum power requirements for each model in this series. Models are listed in alphanumeric order by digit size.

DataMaster Petroleum Price Drop-In Displays					
Model	Dimensions	Weight	Digit Size	Maximum Power	Circuit
DF-2000-10-A-DI DF-2000-10-R-DI DF-2000-10-G-DI	H1'-3", W3'-6", D0'2" (381 x 1067 x 51 mm)	35 lb (16 kg)	10" (254 mm)	All colors = 75 W	120 V AC 15 A
DF-2000-13-A-DI DF-2000-13-R-DI DF-2000-13-G-DI	H1'-6", W4'-0", D0'2" (457 x 1219 x 51 mm)	40 lb (18 kg)	13" (330 mm)	All colors = 75 W	120 V AC 15 A
DF-2000-18-A-DI DF-2000-18-R-DI DF-2000-18-G-DI	H1'-10", W4'-9", D0'2" (559 x 1448 x 51 mm)	45 lb (20 kg)	18" (457 mm)	Amber, red = 75 W Green = 150 W	120 V AC 15 A
DF-2000-24-A-DI DF-2000-24-R-DI DF-2000-24-G-DI	H12'-4", W5'-10", D0'2" (771 x 1778 x 51 mm)	55 lb (25 kg)	24" (457 mm)	Amber, red = 75 W Green = 150 W	120 V AC 15 A
DF-2000-10-A-SF DF-2000-10-R-SF DF-2000-10-G-SF	H1'-3", W3'-0", D0'6 1/8" (381 x 914 x 156 mm)	30 lb (13.6 kg)	10" (254 mm)	All colors = 75 W	120 V AC 15 A
DF-2000-13-A-SF DF-2000-13-R-SF DF-2000-13-G-SF	H1'-6", W4'-0", D0'6 1/8" (457 x 1219 x 156 mm)	35 lb (16 kg)	13" (330 mm)	All colors = 75 W	120 V AC 15 A
DF-2000-18-A-SF DF-2000-18-R-SF DF-2000-18-G-SF	H2'-0", W5'-0", D0'6 1/8" (610 x 1524 x 156 mm)	60 lb (27.2 kg)	18" (457 mm)	Amber, red = 75 W Green = 150 W	120 V AC 15 A
DF-2000-24-A-SF DF-2000-24-R-SF DF-2000-24-G-SF	H2'-6", W6'-6", D0'6 1/8" (762 x 1981 x 156 mm)	90 lb (40,8 kg)	24" (457 mm)	Amber, red = 75 W Green = 150 W	120 V AC 15 A

2.3 Lifting the Display

The full cabinet model DF-2000 will come with eyebolts for mounting purposes. Actual site demands will dictate the appropriate mounting method.

Daktronics strongly recommends using a spreader or lifting bar to lift the display. Using a spreader bar ensures that the force on the eyebolts is straight up, minimizing lifting stress. **Figure 4**, below, illustrates the correct and incorrect lifting methods.

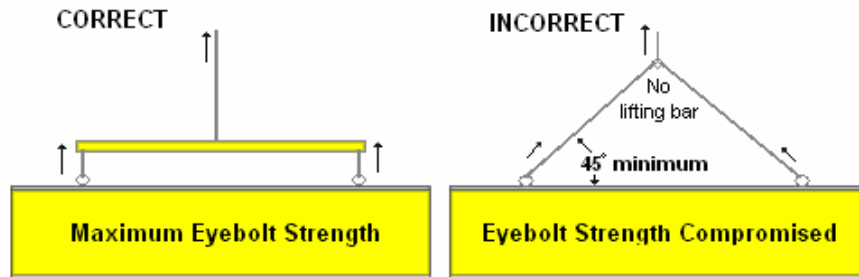

Figure 4: *Lifting the Display*



Daktronics assumes no liability for display damage or injury resulting from incorrect setup or incorrect lifting methods.

Eyebolts are intended for lifting during installation only. Do not attempt to permanently support the display by the eyebolts.

Eyebolts may be removed once the display is in place. The bolt sizes and threads vary based on the size and weight of the display. Common bolts used are 1/4"-20, 3/8"-16, 1/2"-13, and 5/8"-11.

Section 3: Electrical Installation

Electrical installation consists of the following processes, as shown in **Figure 5**:

- Providing power and ground to a disconnect near the display.
- Routing power and ground from the main disconnect to the display driver/power enclosure.
- Connecting the display ground to a grounding electrode at the sign location.
- Routing the control signal cable from the control location to the sign location.

Each of these steps is covered in the following section.

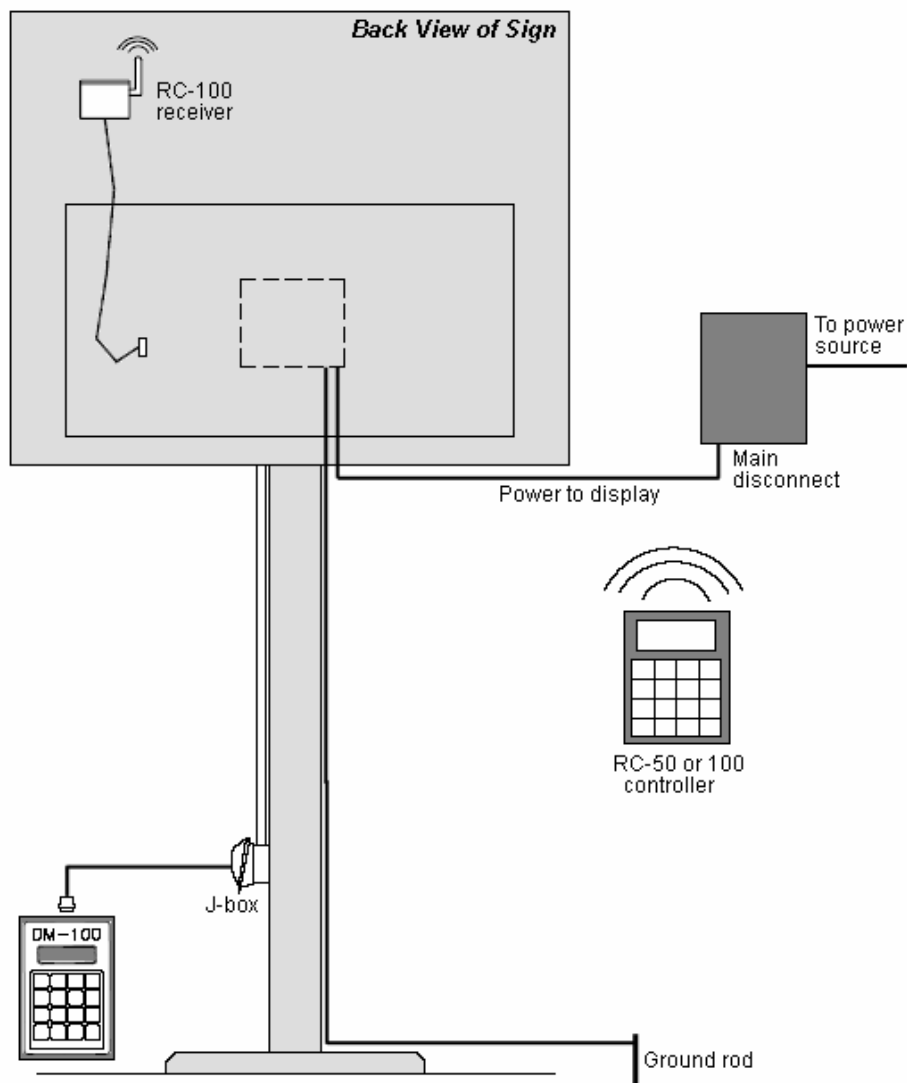

Figure 5: Installation Overview

3.1 Power installation



- Only qualified individuals should perform power routing and termination to the display.
- It is the responsibility of the electrical contractor to ensure that all electrical work meets or exceeds local and national codes.

Reference Drawings:

RC-50 Quick Install Guide	Drawing A-257189
Address Dip Switch Settings	Drawing B-256001
Wiring Schematic DF-2000/4000 Series	Drawing A-263988

Daktronics DataMaster displays have been designed for simple hook-up of power and signal. Correct power installation is imperative for proper display operation. Only qualified individuals should attempt to complete the electrical installation; untrained personnel should not attempt to install these displays or any of the electrical components. Improper installation could result in serious damage to the equipment and could be hazardous to personnel.

The DataMaster outdoor displays require a dedicated, 120 VAC circuit for incoming power. The display itself has no breakers or fuses. Refer to **Drawing A-263988** and the chart in **Section 2** to determine maximum power requirements for a specific model.

It is critical that the display circuit be fused at 15 A, and that all conductors used must be designed to pass a 15 A current in normal operation. Failure to meet wiring and over-current protection device requirements is a violation of the National Electrical Code® and will void the display warranty.

Grounding



Displays **MUST** be grounded according to the provisions outlined in Article 250 of the National Electrical Code and according to the specifications in this manual.

The display system *must* be connected to an earth electrode installed at the display. Proper grounding is necessary for reliable equipment operation. It also protects the equipment from damaging electrical disturbances and lightning. **The display must be properly grounded or the warranty will be void.** Refer to **Schematic Drawing A-263988**.

Important points about grounding:

- Follow local and national codes: The material of an earth-ground electrode differs from region to region and from conditions present at the site. Consult the National Electrical Code and any local electrical codes that may apply.
- Support structure **cannot** be used as an earth-ground electrode: The support is generally embedded in concrete. If embedded in earth, the steel is either primed or it corrodes, making it a poor ground.
- One grounding electrode for each display face: The grounding electrode is typically one grounding rod for each display face. Other grounding electrodes as described in Article 250 of the National Electric Code may be used.

- Resistance to ground 10 ohms or less: This is required by Daktronics for proper display performance. If the resistance to ground is higher than 10 ohms, it will be necessary to install additional grounding electrodes to reduce the resistance. The grounding electrode should be installed within 25 feet of the base of the display. The grounding electrode must be connected to the ground wire inside the display.

Power Disconnect

The National Electrical Code requires the use of a lockable power disconnect within sight of or at the display. The use of a disconnect also significantly protects the circuits against lightning damage. Follow these guidelines for correct connection:

- Connect the grounding electrode cable at the local disconnect, never at the display driver/power enclosure.
- Use a disconnect that opens all of the ungrounded phase conductors.

In order for this device to provide protection, the power **MUST** be disconnected when the display is not in use. The control console should also be disconnected from power and from the signal j-box when the system is not being used. The same surges that may damage the display's driver can also damage the console's circuit.

Power Installation

For this type of installation, the power circuit *must* contain an isolated earth-ground conductor. Power connects to the pigtail inside the display. The pigtail has three wires: black (120 V AC line), white (neutral) and green (ground), and a 5-pin plug on one end. The plug is connected to the mating plug on the transformer. Use wire nuts to connect power wires to the pigtails.



Figure 6: Power Pigtail Wiring

3.2 Signal Connection

Reference Drawing:

Specifications, Gas Price Driver, 4 ColDrawing A-250728

LED Drivers

In the display, the LED driver performs the task of switching digits on and off. One driver at each sign installation is designated as the “host driver.” This driver receives its signal directly from the controller on the Signal In connector J6. The Signal Out connector J8 is used to connect to “client drivers,” the drivers in other displays in this network.

Other communication types are initially connected as shown in the chart: J11 (Radio, RC-100 system) and J12 (RC-50 receiver). These initial connections are then routed to the J6 Input jack. Refer to **Drawings A-250728** for a complete listing of driver connector functions and wiring pin numbers.

4-Column LED Driver	
Connector No.	Function
J1 – 4	Digits
J5	Not loaded
J6	CL Input
J7	Program
J8	CL Output
J9	Not loaded
J10	Modem
J11	Radio
J12	RC-50 Input

Signal Wiring

Signal wires are terminated with a telephone-type RJ14 connector. Route the cable from the jack in the j-box to J6 on the host driver (**Figure 7**). Run another RJ14 connector from J8 (Output) to the next (client) display, connecting at J6 (Input). Follow this sequence to all displays in the sign network.

Address Dip Switch Settings

Every driver, either host or client, must have a unique address. The address is set by moving the individual switches in the eight-position DIP switch case, located on the driver. Addresses allow the user to set both line numbers (switches 1-3) and sign number (switches 4-6) in as many as eight sign groups (**Figure 8**). All displays with the same line number will show the same price.

Refer to **Drawing B-256001** for an illustration of the client/host driver setups and for a line number and sign number settings.

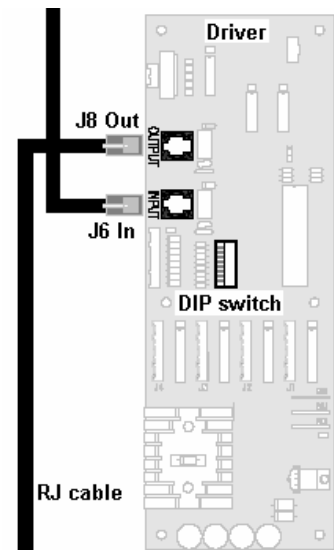

Figure 7: Driver



Figure 8: DIP Switches with #1 and #4 ON (pressed down)

3.3 Power Up Self-test

Every time the display is powered up, it will run through a verification sequence. This is a good way to check that the displays are set up and working correctly. The following items will be shown on the digit displays. The second column explains the significance of each item.

Information shown on display	Meaning of information
rNN	Revision number of software
XLY	X = sign #; L is constant, Y = line #

Section 4: Troubleshooting and Parts Replacement

Daktronics displays are built for long life and require little maintenance. To insure optimal performance, this section provides information on diagnostics and troubleshooting as well as replacing parts. The Replacement Parts List in this section provides the names and part numbers of components that may require replacement during the life of this display. Following the parts list is an explanation of Daktronics Exchange and Repair & Return Programs. Refer to these instructions if parts need to be replaced or repaired.



Important Notes:

- Disconnect power before doing any repair or maintenance work on the display.
- Allow only qualified service personnel access to internal display electronics.
- Disconnect power when not using the display.

4.1 Component Location and Access

For the front-access displays in this series, all internal electronic components and digit boards can be reached by opening the hinged access door on the front of the display. The door swings left when the two latches on the front edge are opened, as shown in **Figure 9**. For front and opened views of the displays, refer to the shop drawings in **Appendix A**.

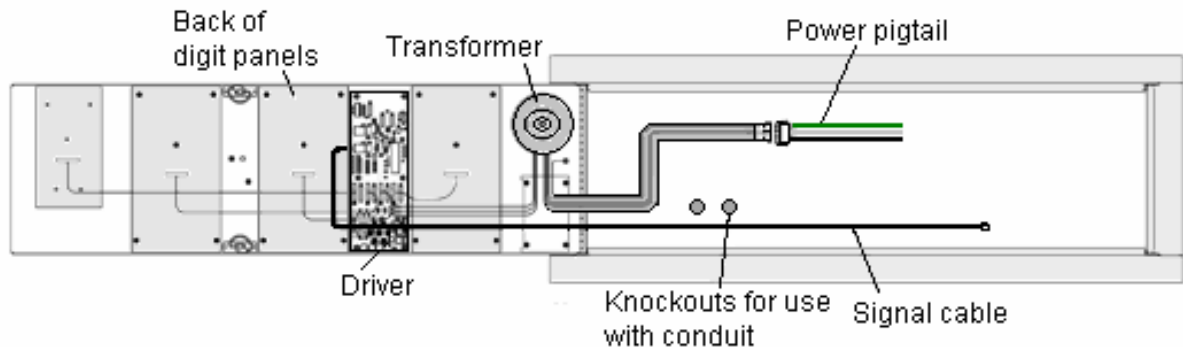

Figure 9: DF-2000, Front View with Face Panel Open

Component placement varies slightly with each DataMaster model; consult the model-specific mechanical drawing to determine the layout for your display.

Note: Disconnect power before servicing the display. Disconnect power, too, when the display is not in use. Prolonged power-on may shorten the life of some electronic components.

4.2 Diagnostics

Driver LEDs

The driver inside the display contains three LEDs that provide information about the working of the display. Refer to **Figure 10** for their location. These LEDs can help pinpoint problems with the driver set-up or operation.

The LEDs provide the following information:

LED	Color	Status
DS1	Green	Continuous light when driver has power.
DS2	Red	Blinks when driver receives signal.
DS3	Amber	Blinks when driver is running.

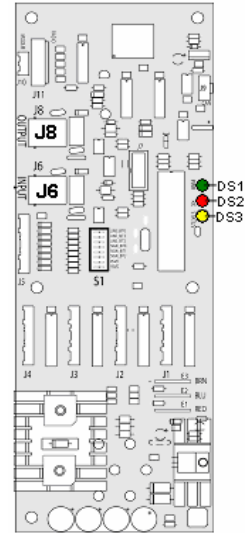

Figure 10: Driver Diagnostics

Power On Self-test

A useful troubleshooting tool is the power on self-test performed by the host driver every time the display powers up. The display should show the information listed in the left column. Sign (X) and Line (Y) numbers refer to the DIP switch settings for the specific display.

Information shown on display	Meaning of information
r N N	Revision number of the software
X L Y	X = Sign #, L is constant, Y = Line #

4.3 Troubleshooting

This section lists potential problems with the display and indicates possible causes. This list does not include every possible problem, but it does represent some of the more common situations that may occur. (Refer to the appropriate manual for a list of potential problems with add-on or separately mounted message centers.

Symptom/ Condition	Possible Cause	Solution
No displays in the sign will light	<ul style="list-style-type: none"> Power incorrectly set up. Addresses not set correctly. 	<ul style="list-style-type: none"> Open display with host driver and check Power LED (Section 4.2). Check each driver to verify correct address settings (Section 3.2).
Multiple line sign with all lines showing same prices	<ul style="list-style-type: none"> Addresses not set correctly. 	<ul style="list-style-type: none"> Set up different address for each line of sign (Section 3.2).
Digit will not light	<ul style="list-style-type: none"> Black wire to digit broken. Poor contact at driver connection. Driver malfunction. 	<ul style="list-style-type: none"> Replace harness. Clean contacts. Replace driver.
Segment or several LEDs will not light	<ul style="list-style-type: none"> Broken LEDs. Driver failure. Broken wire between driver and digit. Poor contact at driver connector. 	<ul style="list-style-type: none"> Replace segment or digit. Replace driver. Replace harness. Clean contact or replace harness.
Segment or digit stays lit	<ul style="list-style-type: none"> Driver failure. Short circuit on digit. 	<ul style="list-style-type: none"> Replace driver. Replace harness.
Data appears in the wrong place on the sign	<ul style="list-style-type: none"> Signal connections are not correct. 	<ul style="list-style-type: none"> Reconnect signal wiring to drivers (Section 3.2).
Data appears on the wrong line of the display	<ul style="list-style-type: none"> Incorrect address settings on drivers. 	<ul style="list-style-type: none"> Change addresses on drivers (Section 3.2).
Display shows "E4".	<ul style="list-style-type: none"> No Message Error: This code is shown when no messages are downloaded to the display. 	<ul style="list-style-type: none"> Download a new message to the display using the [Update Display] key on the DataMaster 100 controller.

4.4 Parts Replacement

Daktronics Petroleum Price Displays are built for long life and easy maintenance. On occasion, however, a part may need to be replaced. In that case, follow these steps:

1. Find the part number label on the part or refer to the chart of part numbers.
2. Read **Section 4.5** for the step-by-step instructions on obtaining a new part.
3. When the part is received, follow the instructions in this section for replacing it.

Description	Daktronics Part No.
Communication Boards and Accessories	
Junction box, outdoor, 9-pin D-male	0A-1196-0093
Junction box, indoor, 9-pin D, male	0A-1196-0099
RC-50 Radio with overlay	0A-1356-0064
Receiver card	0P-1192-0355
Antenna	A-2015
Transformer, wall pack	T-1118
RC-100 Price Display insert	LL-2617
RC-100 hand held assembly	0A-1110-0046
DataMaster 100 hand-held controller	0A-1196-0088
DataMaster 100 outdoor wired installation kit	0A-1356-0002
DataMaster 100 indoor wired installation kit	0A-1356-0105
Drivers and Internal Components	
Toroid Transformer, Display	T-1124
Digit cable, 1 ft.	W-1575
Digit cable, 3 ft.	W-1576
Gas Price Driver, 4-col	0P-1356-0002
Signal Surge Card	0P-1356-0001
Decimal / Driver, red	0P-1192-0353
Decimal / Driver, amber	0P-1192-0355
Decimal / Driver, green	0P-1192-0354

Description	Daktronics Part No.
Digits and Accessories	
Digit, 10" 7-segment, red, 14 pin	0P-1192-0356
Digit, 10" 7-segment, amber, 14 pin	0P-1192-0359
Digit, 10" 7-segment, green, 14 pin	0P-1192-0357
Digit, 13" 7-segment, red, 14 pin	0P-1192-0347
Digit, 13" 7-segment, amber, 14 pin	0P-1192-0348
Digit, 13" 7-segment, green, 14 pin	0P-1192-0349
Digit, 18" 7-segment, red, 14 pin	0P-1192-0341
Digit, 18" 7-segment, amber, 14 pin	0P-1192-0342
Digit, 18" 7-segment, green, 14 pin	0P-1192-0343
22" segment, red, horz., gas price LED digit	0P-1192-0293
22" segment, amber, horz., gas price LED digit	0P-1192-0297
22" segment, green, horz., gas price LED digit	0P-1192-0295
24" segment, red, vert., gas price, LED digit	0P-1192-0372
24" segment, amber, vert., gas price, LED digit	0P-1192-0374
24" segment, green, vert., gas price, LED digit	0P-1192-0373
13", 9/10 digit, red, 14 pin, single Stroke	0P-1192-0378
13", 9/10 digit, amber, 14 pin, single Stroke	0P-1192-0379
13", 9/10 digit, green, 14 pin, single Stroke	0P-1192-0380
16", 9/10 digit, red, 14 pin, single Stroke	0P-1356-0024
16", 9/10 digit, amber, 14 pin, single Stroke	0P-1356-0025
16", 9/10 digit, green, 14 pin, single Stroke	0P-1356-0026
22", 9/10 digit, red, 14 pin, single Stroke	0P-1356-0042
22", 9/10 digit, amber, 14 pin, single Stroke	0P-1356-0043
22", 9/10 digit, green, 14 pin, single Stroke	0P-1356-0044

4.5 Instructions for Replacing Parts

Replacing a Digit Panel

The digit circuit board, the platform for the LEDs, is mounted to the back of the digit panel. Do not attempt to remove individual LEDs. In the case of a malfunctioning board, replace the entire digit panel. Refer to **Figure 11** below.

To remove a display digit, follow these steps:

1. Open the digit panel as described in **Section 4.1**.
2. Disconnect the power/signal connector from the back of the digit. Release the connector by squeezing together the locking tabs as you pull the connector free.
3. The digits are secured to the inside of the panel with fixed machine screws, spacers, and push nuts. Remove the nuts and lift the digit off the standoff screws. (The push nuts can be removed in several ways, but Daktronics recommends using a $\frac{9}{32}$ " nut driver.)
4. Position a new digit over the screws and tighten the nuts.
5. Reconnect the power/signal connector.
Note: This is a keyed connector, it will attach in one way only. Do not attempt to force the connection!
6. Close and secure the digit panel and test the display.

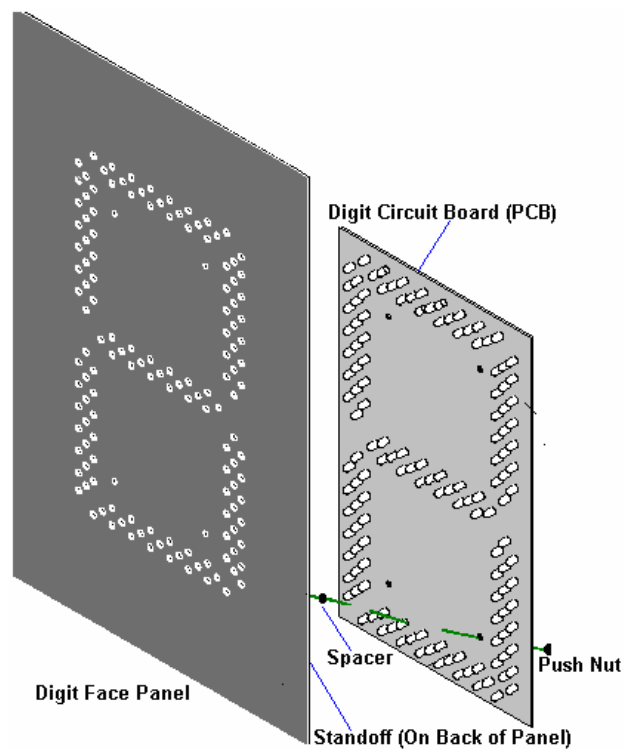

Figure 11: Digit Panel Assembly

Replacing a Digit Segment

Some larger digits (22", 24", 36") may be constructed in segments, as shown in **Figure 12**. It may be possible to make repairs by removing only the defective segment. As with smaller digits, the digit segment circuit boards are mounted to the back of the digit panel. **Do not attempt to remove individual LEDs.**

To remove a digit segment, follow these steps:

1. Open the digit panel as described in **Section 4.1**.
2. Disconnect the 2-pin power/signal connector from the back of the individual segment. Release the connector by squeezing together the locking tabs as you pull the connector free.
3. The individual segments are secured to the inside of the panel with fixed machine screws, spacers, and push nuts. Remove the nuts and lift the segment off the standoff screws.
4. Position a new segment over the screws and tighten the nuts.
5. Reconnect the power/signal connector. **Note:** This is a keyed connector it will attach in one way only. Do not attempt to force the connection!
6. Close and secure the digit panel and test the display.

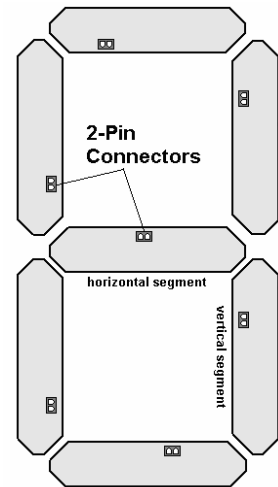

Figure 12: Segmented Digit

Replacing a Driver

Drivers are typically mounted inside the display but location and mounting varies by model. Refer to the component locations drawings for the location of a specific driver. All displays in this manual are front-accessible.

To replace a driver, follow these steps:

1. Open the digit panel or display face panel as described in **Section 4.1**.
2. Remove the cover from the driver enclosure.
3. Disconnect all connectors from the driver. Release each connector by squeezing together the locking tabs as you pull the connector free. **Note:** When reconnecting, remember that these are keyed connectors and will attach in one way only. Do not attempt to force the connections.
4. Remove the screws, nuts, or wing nuts securing the driver to the inside of the enclosure.
5. Carefully lift the driver from the display and place it on a clean, flat surface.
6. Follow steps 1 through 5 in reverse order to attach a new driver.

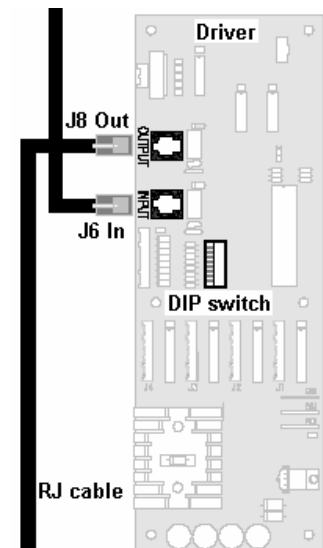

Figure 13: Driver Board

4.6 Daktronics Exchange and Repair & Return Programs

To serve customers' repair and maintenance needs, Daktronics offers both an Exchange Program and a Repair & Return Program.

Exchange Program

Daktronics unique Exchange Program is a quick service for replacing key parts in need of repair. If a part requires repair or replacement, Daktronics sends the customer a replacement, and the customer sends the defective part to Daktronics. This decreases display downtime.

Before Contacting Daktronics

Insert important part numbers here:

Fill in these numbers before calling Customer Service:

Display Serial Number: _____

Display Model Number: DF-2000 Drop-in _____

Contract Number: _____

Date Installed: _____

Location of Display: _____

Daktronics Customer ID Number: _____

To participate in the Exchange Program, follow these steps:

- 1 Call Daktronics Customer Service: 866-343-3122**
- 2 When the new exchange part is received, mail the old part to Daktronics.**

If the replacement part fixes the problem, send in the part which is being replaced.

 - a. Package the old part in the same shipping materials in which the replacement part arrived.
 - b. Fill out and attach the enclosed UPS shipping document.
 - c. Ship the part to Daktronics.
- 3 A charge will be made for the replacement part immediately, unless a qualifying service agreement is in place.**

In most circumstances, the replacement part will be invoiced at the time it is shipped.
- 4 If the replacement part does not solve the problem, return the part within 30 working days or the full purchase price will be charged.**

If the equipment is still defective after the exchange was made, please contact Customer Service immediately. Daktronics expects *immediate return* of an exchange part if it does not solve the problem. The company also reserves the right to refuse parts that have been damaged due to acts of nature or causes other than normal wear and tear.

4.7 Repair & Return Program

1. **Call or fax Daktronics Customer Service:**
Phone: 866-343-3122 Fax: 605-697-4444
2. **Receive a Return Materials Authorization (RMA) number before shipping.**
This expedites repair of the part.
3. **Package and pad the item carefully to prevent damage during shipment.**
Electronic components, such as printed circuit boards, should be placed in an antistatic bag before boxing.
4. **Enclose:**
 - your name
 - address
 - phone number
 - the RMA number
 - a clear description of symptoms

Shipping Address

Daktronics Customer Service
PO Box 5128
331 32nd Avenue
Brookings, SD 57006

Section 5: DM-100 Controller

This section describes the setup and operation of the DataMaster 100 (DM-100) Controller. The DM-100 may be used with either an indoor or outdoor j-box, both of which are explained in this section. Also note the information on the DataMaster insert.

5.1 DataMaster 100 Overview

Reference Drawing:

Address Dip Switch Settings..... **Drawing B-256001**

The DataMaster 100 Series controller, shown in **Figure 9**, is a hand-held controller designed to operate Daktronics LED DataMaster displays. This lightweight controller, 6¹/₄" high by 4¹/₄" wide, is encased in ABS plastic, making it a durable and convenient control option. The console's liquid crystal display (LCD) guides the user through the operation of the system.

The DataMaster 100, identified by the series number DM-100, can be configured to display petroleum price, motel rates, and time and temperature data. Refer to **Drawing B-256001** for information on possible control options and connection procedures.

Note: When this equipment arrives, open the packages and inspect for shipping damage such as rattles and dents. See that all equipment is included as shown on the packing slip. Immediately report any deficiencies to Daktronics. Save all packing materials for shipping if warranty repair or exchange is needed.



Figure 14: DataMaster 100

Replacement Parts List

The following is a list of possible replacement parts for the DataMaster 100 controller. When re-ordering a part, be sure to use its corresponding part number.

Description	Daktronics Part No.
Wall pack transformer	T-1118
DataMaster 100 controller	0A-1196-0088
Control Insert	LL-2551
Cable, DB-9 male to DB-9 female, 10'	W-1267

Refer to **Section 4.8** for details concerning the Daktronics exchange and repair programs.

5.2 Connecting the DM-100 to the Display

Reference Drawing:

Address Dip Switch Settings **Drawing B-256001**

The DataMaster displays may be controlled from a location inside a building, or from the base of the sign, depending on customer preference. **Drawing B-256001** and the subsections that follow provide greater detail on both installations using signal wire.

Wire Control from the Base of the Sign

This control option (**Figure 15**) permits operation of the sign from the base of the display. The controller is connected to an outdoor junction box mounted on the display pole, which routes the signal to the sign through one 2-pair cable, 22 AWG. Cable is in conduit where required.

This control option does not require the controller to be connected to a power outlet. In this configuration, the DataMaster 100 uses the sign as a power source.

To operate the DataMaster display using this setup, connect the 9-pin to 9-pin cable from the DataMaster controller to the j-box mounted on the display pole.

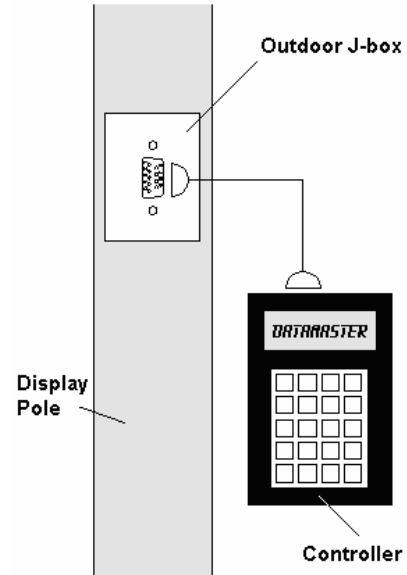

Figure 15: Wire Control Outdoors

Wire Control from a Building Location

This control option, illustrated in **Figure 12**, permits operation of the sign from an indoor control location. The handheld controller is connected to an indoor junction box (j-box), which routes the signal to the sign through one 2-pair cable, 22 AWG. Cable is in conduit where required.

To operate the DataMaster display using this setup, connect the 9-pin to 9-pin cable from the DataMaster controller to the 9-pin j-box, and plug the controller's wall pack transformer into a 120 V AC outlet.

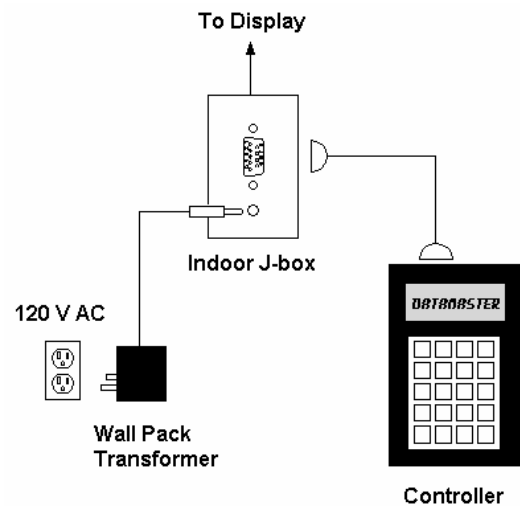

Figure 16: Wire Control from Building Location

5.3 DataMaster Insert and Code

Reference Drawing:

Insert, LL-2551 Price/T&T Display **Drawing A-167856**

The DM-100 uses a keypad insert to program rate information into Daktronics LED DataMaster Rate Displays. The DM-100 insert shown in **Figure 17** is used to control the displays.

If an insert is lost or damaged, make a copy of the insert from **Drawing A-167856** located in **Appendix A**. Cut this to size and slide it into the DM-100 pocket. Use this as a reference until a replacement is received.

To start the controller and begin to program information into the display driver, read the next section carefully to fully understand the operation instructions.

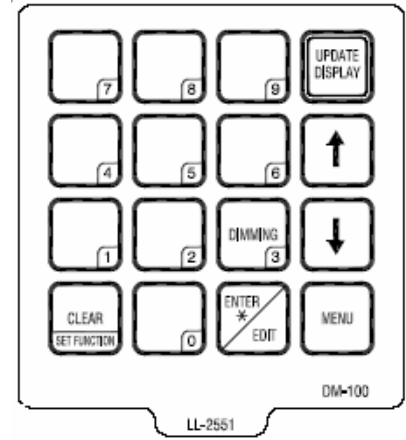

Figure 17: DM-100 Insert

5.4 Petroleum Price Display Operation

The DataMaster 100 controller can be configured to program petroleum price variances displayed on the LED DataMaster Petroleum Price sign. The instructions provided in this section discuss the functions the operator uses to control the Petroleum Price display.

Petroleum Price Display Startup

To operate the DataMaster Gas Price displays, the DataMaster 100 must first be programmed to the gas price function. Use the **[Set Function]** key on startup. Use the following table as a guide to startup procedures.

LCD Screen	Action
<div style="border: 2px solid black; padding: 10px; text-align: center;"> <p>CURRENT FUNCTION GAS PRICE</p> </div>	<p>Plug the wall pack transformer into a 120 V AC power outlet, and connect it to the DataMaster 100.</p> <p>This display appears briefly.</p>

<div style="border: 1px solid black; padding: 5px; text-align: center;"> CHANGE FUNCTION? PRESS SET FUNCT </div>	<p>This message appears next on the screen.</p> <p>If "GAS PRICE" was shown on the bottom line of the LCD during startup, do nothing. The controller will automatically default to previous Gas Price settings.</p> <p>If a function other than "GAS PRICE" was shown on the bottom line of the LCD during startup, press the [Set Function] key while the second LCD prompt is displayed.</p>
<div style="border: 1px solid black; padding: 5px; text-align: center;"> SELECT FUNCTION GAS PRICE ↓↑ </div>	<p>Press the arrow up or down keys [↑↓] until the gas price option is shown. Press the [Enter] key to accept.</p>

The DataMaster 100 handheld controller should now be ready for use. The controller will "remember" the last function setting, so this step should only need to be done with a new controller, or one that is configured for different displays. To operate the DataMaster 100, press any of the keys listed in the following gas price sections.

Petroleum Price Controller Operation

The Petroleum Price Controller LCD display will default to showing the current display settings on power up. The following text will be shown on the LCD.

LCD Screen	Action
<div style="border: 1px solid black; padding: 5px; text-align: center;"> LINE PRICE 1 ↓ \$1.23 9/10 </div> <div style="border: 1px solid black; padding: 5px; text-align: center;"> <EDIT> TO MODIFY 1 ↓ \$1.23 9/10 </div>	<p>The display will toggle between these two screens.</p> <p>Press the up or down arrow keys [↑↓] to scroll through the current setting for any of the lines on the display.</p> <p>Press the [Enter/Edit] key to modify any of the line settings.</p>

Modifying Price Line Settings

The gas price can be modified either by pressing the **[Enter]** key during operation (see **Petroleum Price Controller Operation**) or using the **[Menu]** key (see **Menu Items**). Refer to the following key to identify the item to be edited.

- L = Current line number to be edited
- D.CC = Current dollars and cents value to edit
- T = Current tenths of cent value to edit

LCD Screen	Action
<div style="border: 2px solid black; padding: 5px; width: fit-content; margin: 10px auto;"> EDIT LINE L \$D.CC T/10 ↓ </div>	<p>Press any of the number keys to edit the price value for this line. Press the down arrow key <↓> to modify the value of the 1/10-cent data for this line (see note below).</p> <p>Press [Enter] to accept the new value or press [Clear] to abort the changes.</p> <p>Note: The flashing asterisk on the LCD shows the current data being edited.</p> <p>Many displays do not have a changeable 1/10-cent digit. Changing the tenths-cent value from 9 on these digits will make the digit appear incorrect.</p>

Menu Items

Pressing the [Menu] key accesses the following settings:

Key	Setting
1	Price Line 1
2	Price Line 2
3	Price Line 3
4	Price Line 4
5	Price Line 5
6	LED Test?
7	Display Option
8	Modem Settings
9	Display Status
10	Set Time 12HR

Use Menu items 1-5 to edit the price on each line of the display. Lines are typically numbered top to bottom with 1 being the top of the display. For further details, refer to **Modifying Price Line Settings** discussed previously in this section.

For more information about the Modem Settings submenu, refer to **ED-13953: DataMaster Modem Installation Manual**. For additional information about the Display Status or the Set Time submenus, refer to **ED-13894: DataTime Radio Installation Manual**, that manual provides for complete details on installation and setup for a bi directional radio system.

Modem Settings

The following items for a modem can be set using the DM-100:

Key	Setting
1	Dial Number
2	Dial out prefix
3	Disconnect time
4	Multiple Dial

Display Status

The Display Status menu item can be used with a bi directional display setup to get display status back from the driver. The controller will cycle through various LCD message screens, illustrated below and on the following page, that show display status. Press **[Clear]** at any time to exit the Display Status submenu.

LCD Screen	Action
DIM level xx 0=dim 63=bright	<ul style="list-style-type: none">▪ Dim Level This is the intensity level of the display; 0 is the dimmest setting, and 63 is the brightest setting.
Dimming mode Automatic	<ul style="list-style-type: none">▪ Dimming Mode This is the current mode of dimming used by the display.<ul style="list-style-type: none">▪ <i>Automatic Dimming</i> – The light sensor controls dimming.▪ <i>Manual Dimming</i> – The DM-100 console is used to enter all display dimming information.

LCD Screen	Action
<div style="border: 1px solid black; padding: 5px; width: fit-content;"> Display status Get status? </div>	<p>Press [Enter] to get the status of the display that is connected to the DM-100.</p> <p>The LCD will scroll through the status sent back from the display. Following is a list of responses:</p>
<div style="border: 1px solid black; padding: 5px; width: fit-content;"> Driver Firmware version x.x </div>	<ul style="list-style-type: none"> ▪ <i>Firmware Version</i> This is the firmware version programmed on the host MASC driver in the display.
<div style="border: 1px solid black; padding: 5px; width: fit-content;"> Current day/time mm/dd/yy HH:MM </div>	<ul style="list-style-type: none"> ▪ <i>Current Day/Time</i> This is the Day/Time value set in the driver. The time format used will be 24-hour. <p>Note: To set the Day/Time, see the "Set Time" section of your DataTime display system's operation manual.</p>
<div style="border: 1px solid black; padding: 5px; width: fit-content;"> Last reset time Mm/dd/yy hh:mm </div>	<ul style="list-style-type: none"> ▪ <i>Last Reset Time</i> This time represents the last time the driver was reset. Note that the time format used will be 24-hour.
<div style="border: 1px solid black; padding: 5px; width: fit-content;"> Current temp Xx °f </div>	<ul style="list-style-type: none"> ▪ <i>Current Temp</i> This is the temperature read at the display by the temp sensor. (This value does not include the offset, if applicable).
<div style="border: 1px solid black; padding: 5px; width: fit-content;"> TEMP SENSOR OFFSET Xx °C </div>	<ul style="list-style-type: none"> ▪ <i>Temp Sensor Offset</i> This is the temp sensor offset value programmed into the driver.

Set Time

This allows the time and date to be set with the DM-100.

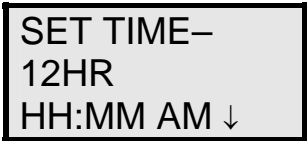
LCD Screen	Action
	<p>HH – Current hours value MM – Current minutes value AM – Current AM/PM setting (not shown when 24-hour time is selected)</p> <p>Using the number keys, enter the Time in the 12-hour (or 24-hour) format. Press the down arrow key <↓> to modify the AM/PM setting.</p> <p>Note: The flashing asterisk shows the current data being edited.</p> <p>To save changes, press the [Enter] key when finished editing.</p> <p>Press the [Clear] key to cancel changes.</p>

After setting the time you will need to set the date. If the date is already correct, enter through the date and press **[Enter]** to send the time to the display.

Dimming

The dimming level of the Rate display can be adjusted in two ways. A light sensor, mounted on each driver, can detect the level of ambient light at the display location and dim the sign's LEDs accordingly. This function is known as automatic dimming. When the manual dimming function is selected, the LEDs remain at the same level of brightness regardless of the level of light detected at the display.

To select either of these functions, press [**Dimming**]. The current setting is shown on the bottom line of the LCD.

LCD Screen	Action
	<p>Press the down arrow key [↓] to toggle through dim settings:</p> <p>Automatic – The display automatically dims based on the light detected at the display</p> <p>Manual – The display dimming level is set manually. Once set, this value remains regardless of the level of light detected at the display.</p>

If **AUTOMATIC** dimming is selected, the following LCD prompt will be shown:

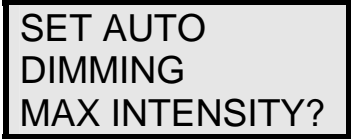
LCD Screen	Action
	<p>Press the [Enter/Edit] key to edit the auto dimming max intensity. This is the maximum intensity that the display will use in full-bright modes (during daylight hours).</p> <p>Press [Clear] to keep the current auto dimming maximum setting.</p>

The following LCD prompt is shown for either Manual or Automatic dimming selections:

LCD Screen	Action
<div data-bbox="321 352 625 491" style="border: 2px solid black; padding: 5px; text-align: center;">INTENSITY XX↓↑ ENTER TO SET</div> <p data-bbox="298 533 602 596">XX – Current intensity (1-16) Max Intensity - 16</p>	<p data-bbox="675 359 1162 457">Press the up or down arrow key [↑↓] to modify the current intensity of the display (Note: The DataMaster must be connected to the display)</p> <p data-bbox="675 499 1162 699">Press [Enter] to accept this intensity. If the manual-dimming mode is selected, this will be the new intensity for the display. If the automatic dimming mode is selected, the display will illuminate in full-bright mode, which is the maximum intensity level.</p>

Update Display

Once connected to the display with a j-box, radio, or modem, press **[Update Display]** to display the new sequence on the display. This button will also allow for a preview of the new sequence on the LCD.

Section 6: RC-50 Controller

The RC-50 controller can be configured to program petroleum price variances displayed on the LED DataMaster Petroleum Price sign. The instructions provided in this section discuss the functions the operator uses to control the Petroleum Price display.

Reference Drawing:

RC-50 Quick install Guide **Drawing A-257189**

6.1 Petroleum Price Display Operation

The RC-50 controller can control four unique prices on multiple signs. The instructions provided in this section discuss the functions the operator uses to control the rate display.

Editing the Display

To edit the price on the display, press and hold any button for 5 seconds. When the sign is in Edit mode, the decimal LEDs blink.

On the RC-50, each pair of buttons corresponds to a price line on the display. Each line is numbered to indicate the line it corresponds to.

Increasing the price

To increase the price by one cent, press [+] for the corresponding line.

Note: Make sure the display is in Edit mode.

Decreasing the price

To decrease the price, press [-] for the corresponding line.

Note: Make sure the display is in Edit mode.

Turbo mode

To rapidly increase or decrease a price, press and hold the button for the corresponding line.

Note: When a button is not pressed for more than 10 seconds, the display exits the Edit Mode. The prices are saved and the display returns to its normal state.



Figure 18: RC-50 Controller

Section 7: RC-100 Controller

The RC-100 controller can be configured to program petroleum price variances displayed on the LED DataMaster Petroleum Price sign. The instructions provided in this section discuss the functions the operator uses to control the Petroleum Price display.

Note: Although multiple wireless handheld controllers may be connected to a single wireless base station server, the rate display application allows for only one handheld device to be connected at a time.

Reference Drawing:

System Riser Diagram; RC-100, DataMaster **Drawing A-244838**

7.1 Petroleum Price Display Operation

The RC-100 controller can be configured to program petroleum price variances displayed on the LED DataMaster Petroleum Price sign. The instructions provided in this section discuss the functions the operator uses to control the Petroleum Price display. Refer to **Drawing A-244838** for correct set-up of the RC-100 system.

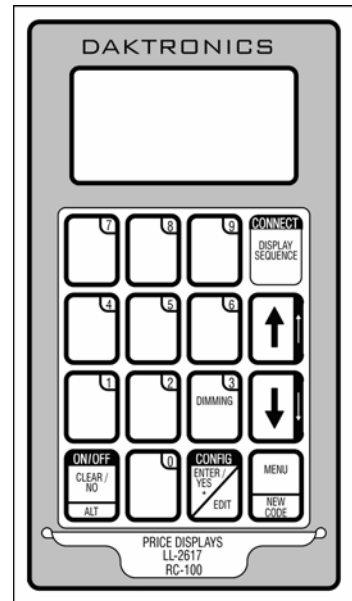

Figure 19: RC-100 Controller

Petroleum Price Display Startup

To operate the DataMaster Petroleum Price displays, the RC-100 must first be programmed to the gas price function. Use the **[Set Function]** key on startup. Use the following table as a guide to startup procedures.

LCD Screen	Action
<div style="border: 2px solid black; padding: 5px; width: fit-content; margin: auto;"> <p>CURRENT FUNCTION GAS PRICE</p> </div>	<p>Plug the wall pack transformer into a 120 V AC power outlet, and connect it to the RC-100.</p> <p>This display appears briefly.</p>

<div style="border: 1px solid black; padding: 5px; text-align: center;"> CHANGE FUNCTION? PRESS SET FUNCT </div>	<p>This message appears next on the screen.</p> <p>If "GAS PRICE" was shown on the bottom line of the LCD during startup, do nothing. The controller will automatically default to previous Gas Price settings.</p> <p>If a function other than "GAS PRICE" was shown on the bottom line of the LCD during startup, press the [Set Function] key while the second LCD prompt is displayed.</p>
<div style="border: 1px solid black; padding: 5px; text-align: center;"> SELECT FUNCTION GAS PRICE ↓↑ </div>	<p>Press the arrow up or down keys [↑↓] until the gas price option is shown. Press the [Enter] key to accept.</p>

The RC-100 handheld controller should now be ready for use. The controller will "remember" the last function setting, so this step should only need to be done with a new controller, or one that is configured for different displays. To operate the RC-100, press any of the keys listed in the following petroleum price sections.

Petroleum Price Controller Operation

The Petroleum Price Controller LCD display will default to showing the current display settings on power up. The following text will be shown on the LCD.

LCD Screen	Action
<div style="border: 1px solid black; padding: 5px; text-align: center;"> LINE PRICE 1 ↓ \$1.23 9/10 </div> <div style="border: 1px solid black; padding: 5px; text-align: center;"> <EDIT> TO MODIFY 1 ↓ \$1.23 9/10 </div>	<p>The display will toggle between these two screens.</p> <p>Press the up or down arrow keys [↑↓] to scroll through the current setting for any of the lines on the display.</p> <p>Press the [Enter/Edit] key to modify any of the line settings.</p>

Modifying Price Line Settings

The petroleum price can be modified either by pressing the **[Enter]** key during operation (see **Petroleum Price Controller Operation**) or using the **[Menu]** key (see **Menu Items**). Refer to the following key to identify the item to be edited.

- L = Current line number to be edited
- D.CC = Current dollars and cents value to edit
- T = Current tenths of cent value to edit

LCD Screen	Action
<div style="border: 1px solid black; padding: 5px; width: fit-content; margin: 10px auto;"> EDIT LINE L \$D.CC T/10 ↓ </div>	<p>Press any of the number keys to edit the price value for this line. Press the down arrow key [↓] to modify the value of the 1/10-cent data for this line (see note below).</p> <p>Press [Enter] to accept the new value or press [Clear] to abort the changes.</p> <p>Note: The flashing asterisk on the LCD shows the current data being edited.</p> <p>Many displays do not have a changeable 1/10-cent digit. Changing the tenths-cent value from 9 on these digits will make the digit appear incorrect.</p>

Dimming

The dimming level of the rate display can be adjusted in two ways. A temperature/light sensor, mounted near the display, can detect the level of ambient light at the display location and dim the sign's LEDs accordingly. This function is known as automatic dimming. When the manual dimming function is selected, the LEDs remain at the same level of brightness regardless of the level of light detected at the display. To select either of these functions, press **[Dimming]**. The current setting is shown on the bottom line of the LCD.

LCD Screen	Action
<div style="border: 1px solid black; padding: 5px; width: fit-content; margin: 10px auto;"> DIMMING AUTOMATIC ↓ </div>	<p>Press the down arrow key [↓] to toggle through dim settings:</p> <p>Automatic – The display automatically dims based on the light detected at the display</p> <p>Manual – The display dimming level is set manually. Once set, this value remains regardless of the level of light detected at the display.</p> <p>Blank Sign – The display can be blanked out without powering down. Refer to the blank sign section for details.</p>

<div style="border: 1px solid black; padding: 5px; text-align: center;"> <p>SET AUTO DIMMING MAX INTENSITY?</p> </div>	<p>Press the [Enter/Edit] key to edit the auto dimming max intensity. This is the maximum intensity that the display will use in full-bright modes (during daylight hours.)</p> <p>Press [Clear] to keep the current auto dimming maximum setting</p>
<div style="border: 1px solid black; padding: 5px; text-align: center;"> <p>INTENSITY XX↓↑ ENTER TO SET</p> </div> <p>XX – Current intensity (1-16) Max Intensity - 16</p>	<p>Press the up or down arrow key [↑↓] to modify the current intensity of the display (Note: The DataMaster must be connected to the display)</p> <p>Press [Enter] to accept this intensity. If manual dimming mode is selected, this will be the new intensity for the display. If the automatic dimming mode is selected, the display will illuminate in full-bright mode, which is the maximum intensity level.</p>
<div style="border: 1px solid black; padding: 5px; text-align: center;"> <p>DIMMING BLANK SIGN ↓</p> </div> <div style="border: 1px solid black; padding: 5px; text-align: center; margin-top: 10px;"> <p>BLANK THE SIGN? <ENT> YES <CLR> NO</p> </div>	<p>Press [Enter] to accept this option.</p> <p>The next LCD dialog will ask whether you want to blank the screen or escape. The LCD toggles between Yes and No. Pressing [Clear] resumes normal operation; pressing [Enter] actually blanks the sign.</p>

Section 8: POS Interface Installation and Operation

A Point of Sale (POS) interface option is available with DataMaster LED Petroleum Price Displays. Displays with this option automatically update when product prices are changed in the POS. Displays with the POS interface option will be supplied with a POS Interface Kit (see table below for part numbers).

P.O.S. Interface Type	Interface Kit Required	Interface Cable	Riser Diagram
Gilbarco G-Site	0A-1279-0400	0A-1279-0402	200195
Gilbarco PAM 1000	0A-1279-0452	0A-1279-0229	224628
Allied	0A-1279-0443	0A-1279-0144	215840

8.1 Installation Preparation

1. Ensure that the POS system has a price sign output port, and refer to the POS manuals to enable and/or configure the port.
2. Locate the parts in the list below.

8.2 Hardware installation:

1. Locate the following parts:
 - a) POS Interface Kit containing:
 - i) DataMaster 100 w/POS option (0A-1196-0133)
 - ii) Wall mounting bracket for DM-100 (0M-200082)
 - iii) POS Interface Cable (refer to table 7-1 for part number)
 - iv) POS riser diagram (refer to table 7-1)
 - b) 10' cable, DB9 to DB9 (W-1267)
 - c) Indoor junction box (0A-1196-0099) for direct wired installations or Radio Interface junction box (0A-1279-0161) for wireless installations.
 - d) Wallpack transformer (T-1118).
2. The wall mount bracket (0M-200082) provides convenient storage for the DM-100 controller. If using the wall mount bracket for the DM-100, ensure that there is sufficient clearance above the bracket to allow the DM-100 to be removed from the bracket with both cables attached. Also ensure that the POS interface cable will reach from the DM-100 location to the price sign output of the POS. Fasten the wall mount bracket if desired. The DM-100 can be permanently attached to the wall mounting bracket by removing the two screws in the bottom edge of the DM-100, sliding the DM-100 into the wall mount bracket, and reinstalling the screws through the slots in the bottom bracket flange.
3. Mount the junction box, refer to step 1.c. above. Ensure that the DB9 to DB9 cable (W-1267) will reach from the DM-100 to the junction box.
4. Complete junction box to sign, or junction box to radio wiring as shown on the riser diagram (drawing 200195).
5. Attach the POS interface cable to the POS price sign port. Coil any excess cable and cable tie it out of the way.

6. Attach the DB9 to DB9 cable (W-1267) to the junction box as shown on the riser diagram. Coil any excess cable and cable tie it out of the way.
7. Plug the transformer (T-1118) into an outlet, and connect the output to the power jack on the J-box.
8. Ensure that the DM-100 is up and running. Send a price change to the sign to verify communications between the sign and the DM-100.

8.3 Configuring the DM-100 for Gilbarco G-Site Interface

Preparation

The DM-100 function must be set to "GAS PRICE." The current function of the DM-100 is displayed during power up. To change to function, cycle power to the DM-100, and press the **[Set Function]** key when prompted.

Configuration

1. Press the **[Menu]** key and use the <↑> and <↓> keys to scroll to the "POS SETTINGS" menu item.

POS SETTINGS
 ENT TO MODIFY ↓↑

Press **[Enter]**.

2. Select the POS type by using the <↑> and <↓> keys to scroll to "GILBARCO GSITE."

POS INTERFACE
 GILBARCO GSITE ↓↑

Press **[Enter]**.

3. Each price in the Gilbarco G-Site is uniquely identified by 'price category'. Each price category corresponds to the price assigned to a particular grade/service level/price level. Use the menu shown below to configure which price category you would like displayed on each line of the display.

PRICE CATEGORY
 LINE 1 : 1 ↓↑

Use the <↑> and <↓> keys to select a price category to be displayed on line 1 of the sign. Press **[Enter]** to accept the setting. Pressing **[Enter]** when the price category displayed is **[None]** will cause the price sign to ignore POS data for this line. (This may be useful for configuring some lines of a price sign to receive manual price changes only).

4. Select a price category to be displayed on each line of the sign, and press **[Menu]**, or **[Esc/Clear]** when finished. The POS interface configuration is complete.

8.4 Configuring the DM-100 for Allied Interface

Preparation

The DM-100 function must be set to "GAS PRICE." The current function of the DM-100 is displayed during power up. To change to function, cycle power to the DM-100, and press the [Set Function] key when prompted.

Configuration

1. Press the [Menu] key and use the <↑> and <↓> keys to scroll to the "POS SETTINGS" menu item.



POS SETTINGS
ENT TO MODIFY ↓↑

Press [Enter].

2. Select the POS type by using the <↑> and <↓> keys to scroll to "ALLIED."



POS INTERFACE
ALLIED ↓↑

Press [Enter].

3. Each price in Allied is uniquely identified by grade, service level, and price level. Use the <↑> and <↓> keys to select a grade for the line. (If a line is not used select [None Displayed].)



GRADE ON LINE 1
GRADE 1 ↓↑

Press [Enter].

4. Use the <↑> and <↓> keys to select a service level for the line.



SERVICE LINE 1
SELF SERVE ↓↑

Press [Enter].

5. Use the <↑> and <↓> keys to select a price level (cash or credit).



PRICE LINE 1
CASH PRICE ↓↑

Press [Enter].

6. Select a grade/service level/price level for each line of the sign, and press [Menu], or [Esc/Clear] when finished. The POS interface configuration is complete.

8.5 Configuring the DM-100 for PAM 1000 Interface

Preparation

The DM-100 function must be set to "GAS PRICE." The current function of the DM-100 is displayed during power up. To change to function, cycle power to the DM-100, and press the **[Set Function]** key when prompted.

Note: The Gilbarco PAM 1000 is a pump access module that allows 3rd party POS systems to interface to and control Gilbarco pumps. The PAM 1000 does not have a dedicated price sign port. The DM-100 "listens" to the price data that is sent from the P.O.S. to the PAM 1000 when prices are changed on the pumps.

Configuration

1. Press the **[Menu]** key and use the <↑> and <↓> keys to scroll to the "POS SETTINGS" menu item.



A rectangular box with a black border containing the text "POS SETTINGS" on the top line and "ENT TO MODIFY ↓↑" on the bottom line.

Press **[Menu]**.

2. Select the POS type by using the <↑> and <↓> keys to scroll to "PAM 1000."



A rectangular box with a black border containing the text "POS INTERFACE" on the top line and "PAM 1000 ↓↑" on the bottom line.

Press **[Menu]**.

3. Each price in the PAM 1000 is uniquely identified by a "system grade number" and a "price level" (cash or credit). For Verifone Ruby P.O.S. systems, the system grade numbers are the same as the product numbers in the Ruby (when setting prices in the Ruby, the first product listed in "system grade 1"). Use the <↑> and <↓> keys to select a grade for the line. If a line is not used select **[None Displayed]**.

Note: Only self service prices may be displayed when using the Ruby.

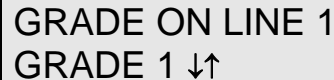

A rectangular box with a black border containing the text "GRADE ON LINE 1" on the top line and "GRADE 1 ↓↑" on the bottom line.

Press **[Enter]**.

4. Use the <↑> and <↓> keys to select a price level (cash or credit).



A rectangular box with a black border containing the text "PRICE LINE 1" on the top line and "CASH PRICE ↓↑" on the bottom line.

Press **[Enter]**.

5. Select a grade for each line of the sign, and press **[Menu]**, or **[Esc/Clear]** when finished. The POS interface configuration is complete.

8.6 Changing Prices:

Each display line for which a price category is configured will automatically update when the price is changed in the POS system. Attempting to manually edit prices that are configured for POS control will cause the following screen to appear:

THIS LINE POS
CTRLD. OVERRIDE?

Press **[Enter]** to manually edit the price, or **[Esc/Clear]** to cancel.

Appendix A: Reference Drawings

The Daktronics drawing number is located in the bottom right corner of the drawing. Refer to **Section 1.1** for instructions on locating the drawing number.

Drawings in this appendix are grouped into general and display type. The shop drawings are listed by model type and digit size.

General Drawings

Insert, DM-100 Price/T&T Display	Drawing A-167856
System Riser Diagram; RC-100, DataMaster	Drawing A-244838
Specifications; Gas Price Driver, 4 Col	Drawing A-250728
RC-50 Quick Install Guide	Drawing A-257189
Wiring Schematic, DF-2000/4000 Series	Drawing A-263988
Models, DF-2000 Drop-In Displays	Drawing A-308916
Address Dip Switch Settings	Drawing B-256001

Shop Drawings, listed by display type and digit size

Shop Drawing DF-2000-10-X-NA-DI	Drawing B-294457
Shop Drawing DF-2000-13-X-NA-DI	Drawing B-294734
Shop Drawing DF-2000-18-X-NA-DI	Drawing B-294758
Shop Drawing DF-2000-24-X-NA-DI	Drawing B-294487
Shop Drawing DF-2000-10-X-NA-SF	Drawing B-295518
Shop Drawing DF-2000-13-X-NA-SF	Drawing B-294987
Shop Drawing DF-2000-18-X-NA-SF	Drawing B-295355
Shop Drawing DF-2000-24-X-NA-SF	Drawing B-295722

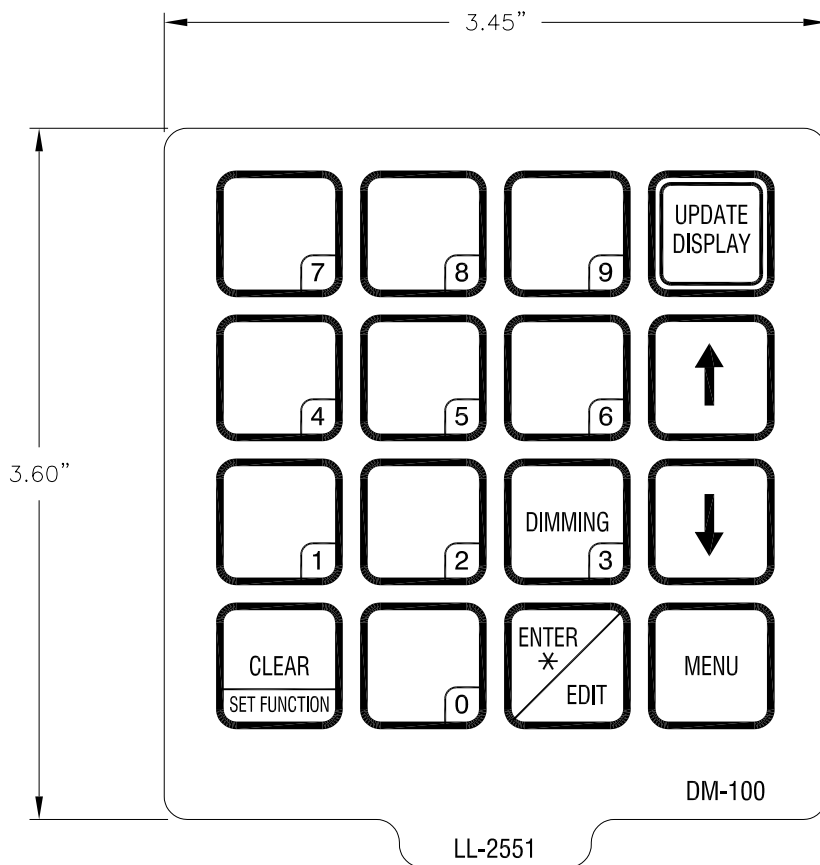

THE CONCEPTS EXPRESSED AND DETAILS SHOWN ON THIS DRAWING ARE CONFIDENTIAL AND PROPRIETARY. DO NOT REPRODUCE BY ANY MEANS, INCLUDING ELECTRONICALLY WITHOUT THE EXPRESSED WRITTEN CONSENT OF DAKTRONICS, INC. COPYRIGHT 2002 DAKTRONICS, INC.			
DAKTRONICS, INC. BROOKINGS, SD 57006			
PROJ:			
TITLE: INSERT, DM-100 PRICE/T&T DISPLAY			
DES. BY: EBRAVEK		DRAWN BY: EBRAVEK	
		DATE: 28 MAY 02	
REVISION	APPR. BY:	1196-E07A-167856	
00	SCALE: 1=1		

REV.	DATE	DESCRIPTION	BY	APPR.

NOTE: THIS DETAIL SHOWS A GENERIC PRICE DISPLAY. ACTUAL DISPLAY MAY BE DIFFERENT FROM DRAWING.

FRONT VIEW

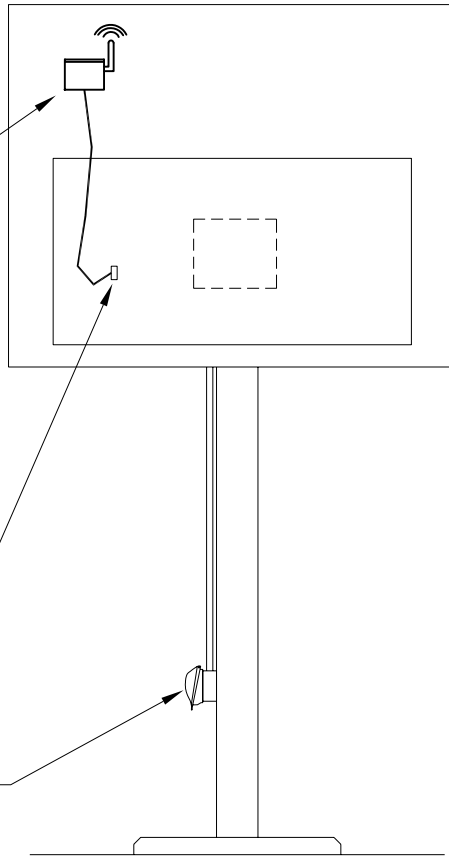

OA-1110-0045
FUNCTION SETTING = 3

NOTE: THE RC-100 RECEIVER BASE STATION NEEDS TO BE MOUNTED SO THAT THE ANTENNA IS IN LINE OF SIGHT WITH THE RC-100 HANDHELD.

NOTE: THE RC-100 RECEIVER BASE STATION CONNECTS TO THE HOST DISPLAY THROUGH A 6 PIN JACK ON THE BACK OF THE DISPLAY.

OPTIONAL
DM-100 WIRED
CONTROL J-BOX

NOTE:
THE WIRELESS BASE STATION COMES PRE-SET TO CHANNEL 1. HOWEVER, CHANNELS 1-15 CAN BE USED.

FUNCTION TABLE

FUNCTION NUMBER	DESCRIPTION
0	DEFAULT FUNCTION (LAST POWER UP FUNCTION)
1	CAN HAND HELD (JUDGES) CONSOLE
2	BASEBALL/TENNIS SCOREBOARD CONTROLLER (ALLSPORT)
3	DATATIME/DATAMASTER DISPLAY CONTROL

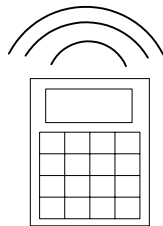

OA-1110-0033
INSERT: LL-2617
(GAS PRICE DISPLAY)

THE CONCEPTS EXPRESSED AND DETAILS SHOWN ON THIS DRAWING ARE CONFIDENTIAL AND PROPRIETARY. DO NOT REPRODUCE BY ANY MEANS, INCLUDING ELECTRONICALLY WITHOUT THE EXPRESSED WRITTEN CONSENT OF DAKTRONICS, INC. COPYRIGHT 2005 DAKTRONICS, INC.

DAKTRONICS, INC. BROOKINGS, SD 57006

PROJ: DATAMASTER LED DISPLAYS

TITLE: SYSTEM RISER DIAGRAM; DATAMASTER, RC-100

DES. BY: KBIERBA

DRAWN BY: KBIERBA

DATE: 9 JUN 05

REV.	DATE	DESCRIPTION	BY	APPR.
01	01 AUG 05	REVISED TEXT	CMG	

REVISION	APPR. BY:
01	MMILLER
	SCALE:
	NONE

1279-R01A-244838

GAS PRICE DECIMAL / DRIVER
 OP-1192-0353 RED
 OP-1192-0354 GRN
 OP-1192-0358 AMB
 OP-1192-0390 SEG TIMER

J10: MODEM

PIN	FUNCTION
5	MODEM_RX_P
4	GND
3	MODEM_TX_P
2	MODEM_RESET_P
1	MODEM_RTS_P

J11: RADIO

PIN	FUNCTION
1	RS232_TX_P
2	RS232_RX_P
3	GND_N
4	+V_UNREG_P
5	DCD_P
6	RESET_P

J8: CL_OUTPUT

PIN	FUNCTION
1	N/C
2	CL_OUT_TX_N
3	CL_OUT_TX_P
4	CL_OUT_RX_N
5	CL_OUT_RX_P
6	N/C

J6: CL_INPUT

PIN	FUNCTION
1	+10V_UNREG
2	CL_IN_TX_P
3	CL_IN_TX_N
4	CL_IN_RX_P
5	CL_IN_RX_N
6	GND

J5: SWITCH INPUTS

PIN	FUNCTION
14	N/C
13	N/C
12	N/C
11	N/C
10	+5V_P
9	SW_7_P
8	SW_6_P
7	SW_5_P
6	SW_4_P
5	SW_3_P
4	SW_2_P
3	SW_1_P
2	SW_0_P
1	GND_N

J12: RC 50 INPUT

PIN	FUNCTION
1	+3.3V_P
2	N/C
3	GND
4	DATA_INPUT_P

J7: PROGRAM

FUNCTION	PIN	PIN	FUNCTION
PGC_P	1	2	VPP_P
NC	3	4	GND_N
PGD_P	5	6	GND_N
PGM_P	7	8	+5V_P
NC	9	10	NC

S1: OPTIONS

PIN	FUNCTION
1	LINE_BIT_0
2	LINE_BIT_1
3	LINE_BIT_2
4	SIGN_BIT_0
5	SIGN_BIT_1
6	SIGN_BIT_2
7	RESERVED
8	RESERVED

J1-4: DIGIT OUTPUTS

PIN	FUNCTION
14	+VBB_P
13	+VBB_P
12	+VBB_P
11	+VBB_P
10	+VBB_P
9	N/C
8	SEGH_N
7	SEGG_N
6	SEGF_N
5	SEGE_N
4	SEGD_N
3	SEGC_N
2	SEGB_N
1	SEGA_N

POWER INPUTS

PIN	FUNCTION
E3	20VAC_P_BRN
E2	10VAC_P_BLU
E1	VAC_N_RED

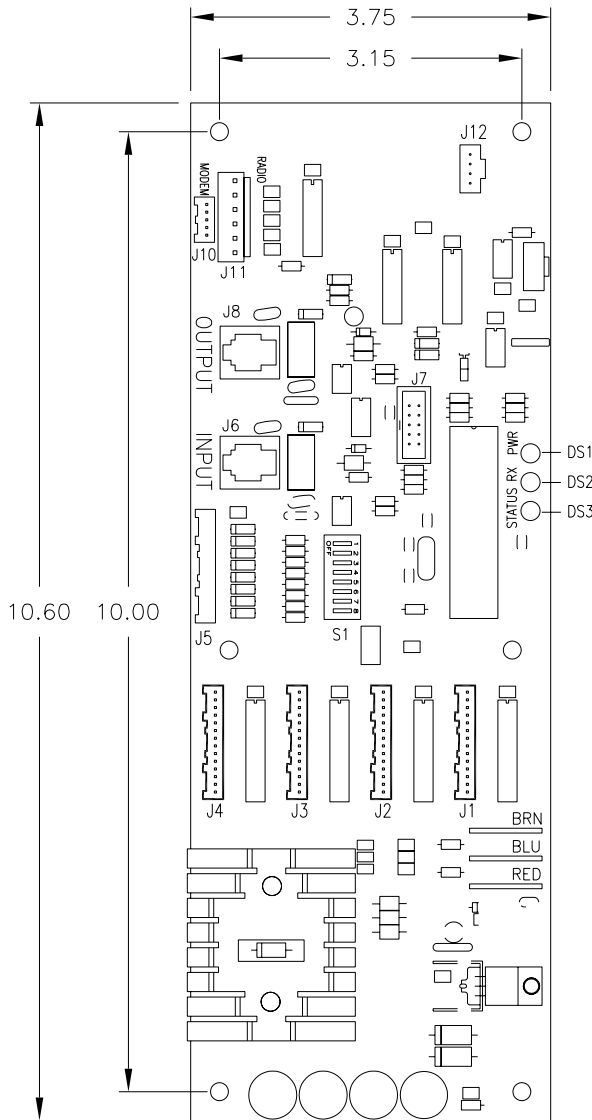

NOTES:

- GREEN LED DS1 INDICATES THAT THE DRIVER HAS POWER.
- RED LED DS2 WILL FLICKER WHEN THE DRIVER RECEIVES SIGNAL.
- AMBER LED DS3 WILL BLINK WHEN THE DRIVER IS RUNNING.
- IF DS3 IS ON OR OFF CONTINUOUSLY THE MICROCONTROLLER IS NOT WORKING.
- REFER TO DWG B-256001 FOR SWITCH SETTING DETAILS.

THE CONCEPTS EXPRESSED AND DETAILS SHOWN ON THIS DRAWING ARE CONFIDENTIAL AND PROPRIETARY. DO NOT REPRODUCE BY ANY MEANS, INCLUDING ELECTRONICALLY WITHOUT THE EXPRESSED WRITTEN CONSENT OF DAKTRONICS, INC. COPYRIGHT 2005 DAKTRONICS, INC.			
DAKTRONICS, INC. BROOKINGS, SD 57006			
PROJ: REDUCED DEPTH GAS DISPLAYS			
TITLE: SPECIFICATIONS; GAS PRICE DRIVER, 4 COL.			
DES. BY: THENDRI		DRAWN BY: DULSCHM	DATE: 11 AUG 05
REVISION	APPR. BY:	1356-R04A-250728	
03	SCALE: 1 = 2		

REV.	DATE	DESCRIPTION	BY	APPR.
03	22 AUG 06	CHANGED SEG TIMER TO OP-1192-0390	DJU	
02	28 FEB 06	REMOVED FUNCTION TABLE FOR J9: CAN ADDED FUNCTION TABLE FOR J12: RC 50	DJU	
01	04 OCT 05	UPDATED DRAWING FOR REV 01 PCB	DJU	

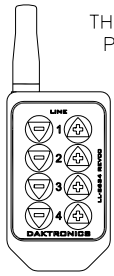

FRONT VIEW
RC-50
CONTROLLER

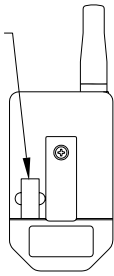

REAR VIEW
RC-50
CONTROLLER

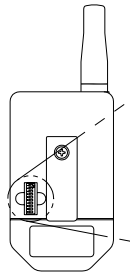

REAR VIEW
RC-50
CONTROLLER

9 & 0 NOT USED

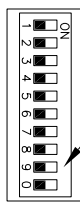

DIP SWITCH DETAIL
SCALE 2=1
(THIS IS AN EXAMPLE ONLY,
NOT THE ACTUAL SETTINGS)

REMOVE THE DIP SWITCH COVER ON THE BACK OF THE RC-50 CONTROLLER.

USE A THIN, POINTED OBJECT TO MOVE THE SWITCHES RIGHT OR LEFT TO TURN THEM ON OR OFF.

SET THE FIRST 8 SWITCHES OF THE RC-50 DIP SWITCH TO A RANDOM UNIQUE SETTING. RECORD YOUR SETTING IN THE TABLE BELOW.

ONLY THE FIRST 8 SWITCHES ARE USED. SWITCHES 9 AND 0 DO NOT AFFECT THE ADDRESS, REGARDLESS OF THEIR POSITIONS.

REPLACE THE COVER.

SET THE DIP SWITCH ON THIS DRIVER TO MATCH THE RC-50 DIP SWITCH. THIS DISPLAY WILL OPERATE AS LINE 1.

SET DRIVER DIP SWITCH TO SIGN 1 LINE 2

SET DRIVER DIP SWITCH TO SIGN 1 LINE 3

SEE DRAWING 1356-R10B-256001 FOR INFORMATION ON SETTING DRIVER DIP SWITCHES.

FOR A 2-SIDED SIGN, SET ADDRESS FOR ONE SIDE AS SIGN 1, AND USE SIGN 2 FOR THE OTHER SIDE.

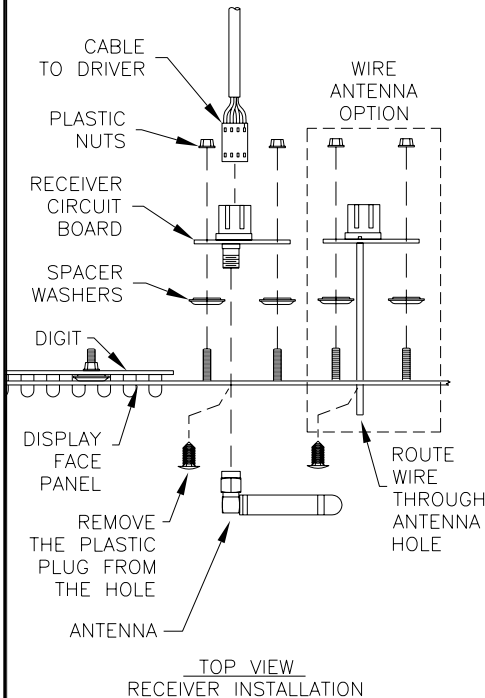
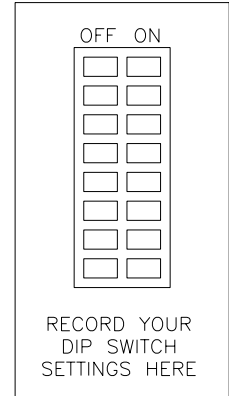
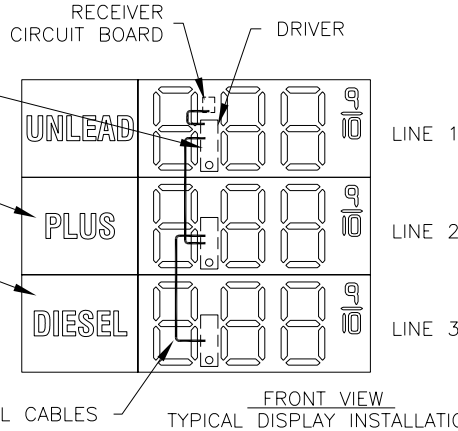

1. SET THE FIRST 8 SWITCHES OF THE RC-50 DIP SWITCH TO A UNIQUE RANDOM SETTING. RECORD YOUR SETTING FOR FUTURE REFERENCE.

2. SET THE DIP SWITCH ON THE DRIVER THAT WILL BE CONNECTED TO THE RECEIVER, USING THE SAME SETTING AS THE 8 RC-50 SWITCHES.

3. MOUNT THE RECEIVER CIRCUIT BOARD IN THE DISPLAY, AS SHOWN AT LEFT. ROUTE WIRE THROUGH ANTENNA HOLE IN DISPLAY FACE PLATE FOR WIRE ANTENNA OPTION.

4. CONNECT SIGNAL CABLE FROM OUTPUT ON THAT DRIVER TO INPUT ON THE NEXT DRIVER. CONTINUE CONNECTING FROM OUTPUT TO INPUT UNTIL ALL DRIVERS ARE CONNECTED.

5. SET THE DIP SWITCHES ON THE OTHER DRIVERS TO BE LINE 2, LINE 3, ETC. SEE DRAWING 1356-R10B-256001 FOR INFORMATION ON SETTING DRIVER DIP SWITCHES.

6. POWER UP THE SIGN AND OPERATE THE RC-50 CONTROLLER. LINE 1 WILL OPERATE THE DISPLAY WITH THE RECEIVER, ALONG WITH ANY OTHER DISPLAY THAT IS SET TO LINE 1.

7. PRESS AND HOLD ANY KEY ON THE RC-50 FOR 5 SECONDS. THE DECIMAL ON THE DISPLAY WILL FLASH. PRESS [-] OR [+] TO DECREASE OR INCREASE THE PRICE BY 1 CENT.

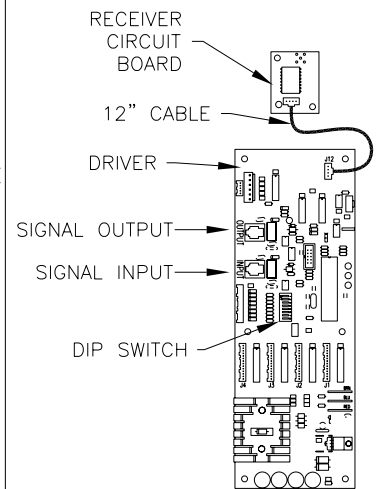

REAR VIEW
RECEIVER AND DRIVER

THE CONCEPTS EXPRESSED AND DETAILS SHOWN ON THIS DRAWING ARE CONFIDENTIAL AND PROPRIETARY. DO NOT REPRODUCE BY ANY MEANS, INCLUDING ELECTRONICALLY WITHOUT THE EXPRESSED WRITTEN CONSENT OF DAKTRONICS, INC. COPYRIGHT 2005 DAKTRONICS, INC.

DAKTRONICS, INC. BROOKINGS, SD 57006

PROJ: GAS PRICE DISPLAYS

TITLE: RC-50 QUICK INSTALL GUIDE

DES. BY: KBIERBA

DRAWN BY: KBIERBA

DATE: 11 NOV 05

REVISION

APPR. BY:

02

SCALE:

NONE

1356-R10A-257189

REV.	DATE	DESCRIPTION	BY	APPR.
02	21 JUL 06	ADDED DETAIL TO SHOW WIRE ANTENNA OPTION ADDED TEXT TO INSTALLATION INSTRUCTIONS	DJU	
01	08 JUN 06	CHANGED DIP SWITCH FIGURE TO SHOW 10 POSITION SWITCH WITH THE FIRST EIGHT BEING USED.	AVB	

DUAL TRANSFORMERS
 TWO TRANSFORMERS ARE
 USED WITH 18" AND 24"
 GREEN DIGIT DISPLAYS

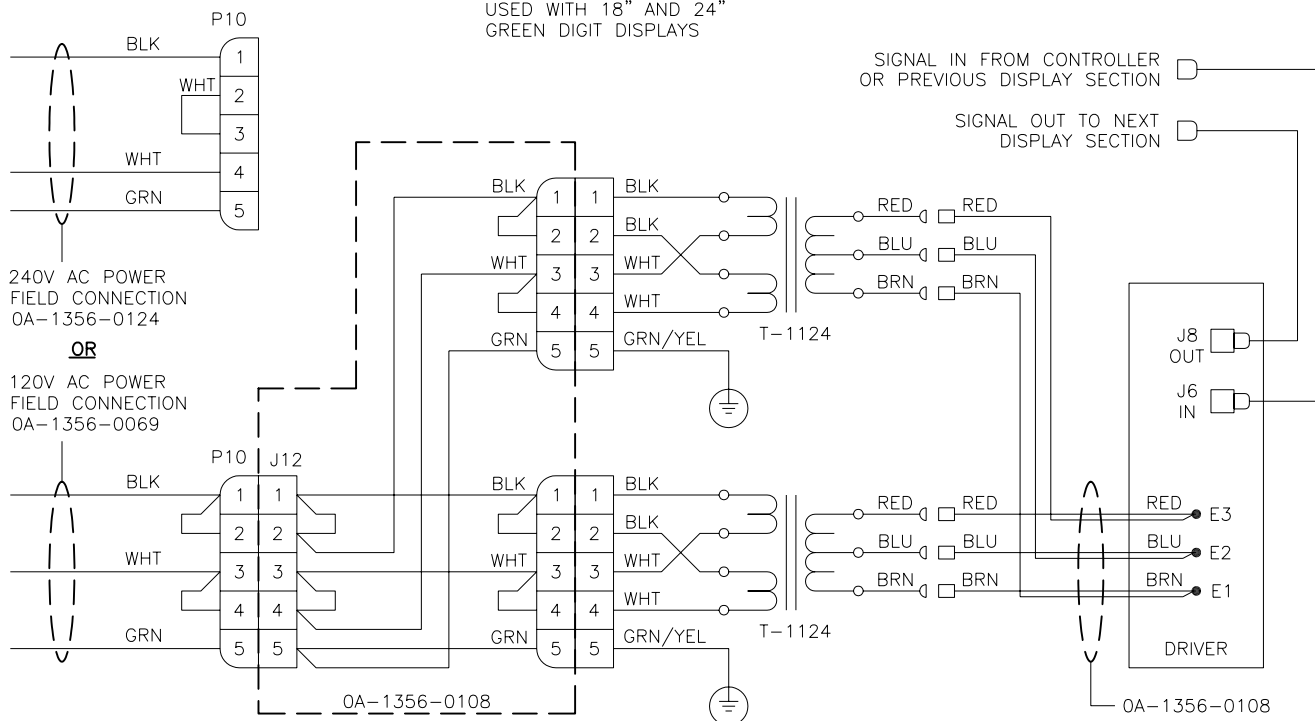

SINGLE TRANSFORMER

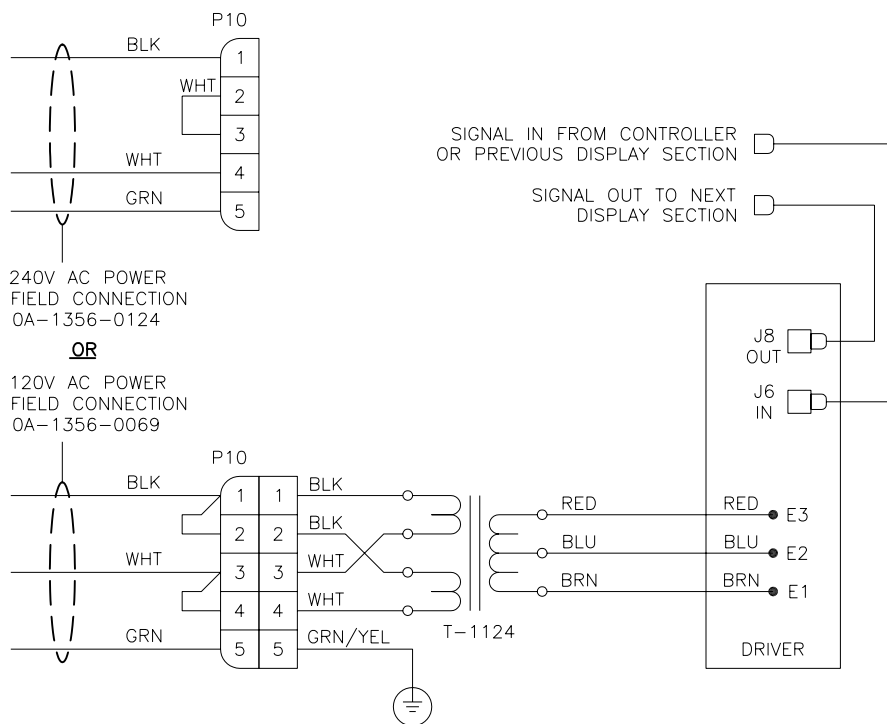

THE CONCEPTS EXPRESSED AND DETAILS SHOWN ON THIS DRAWING ARE CONFIDENTIAL AND PROPRIETARY. DO NOT REPRODUCE BY ANY MEANS, INCLUDING ELECTRONICALLY WITHOUT THE EXPRESSED WRITTEN CONSENT OF DAKTRONICS, INC. COPYRIGHT 2005 DAKTRONICS, INC.			
DAKTRONICS, INC. BROOKINGS, SD 57006			
PROJ: GAS PRICE DISPLAYS			
TITLE: WIRING SCHEMATIC, DF-2000/4000 SERIES			
DES. BY: AVB	DRAWN BY: KBIERBA	DATE: 09 FEB 06	
REVISION	APPR. BY:	1356-R03A-263988	
01	SCALE: NONE		

01	27 SEP 06	REDREW THE SCHEMATIC TO INCLUDE UPDATED HARNESSING.	MGL	
REV.	DATE	DESCRIPTION	BY	APPR.

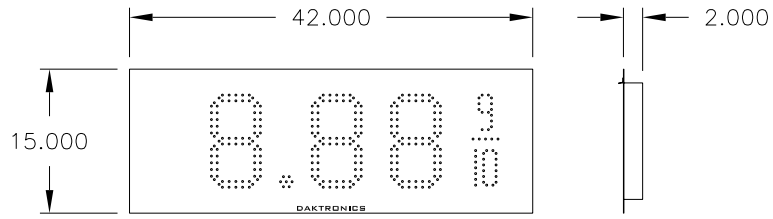

DF-2000-10-NA-DI

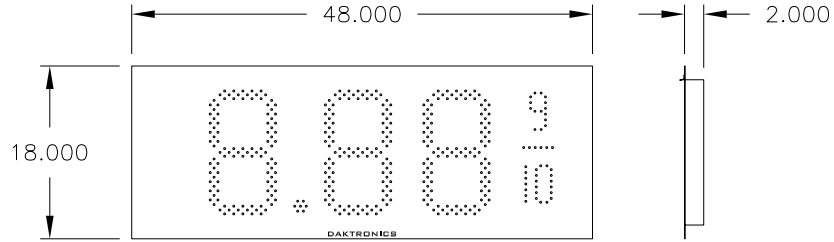

DF-2000-13-NA-DI

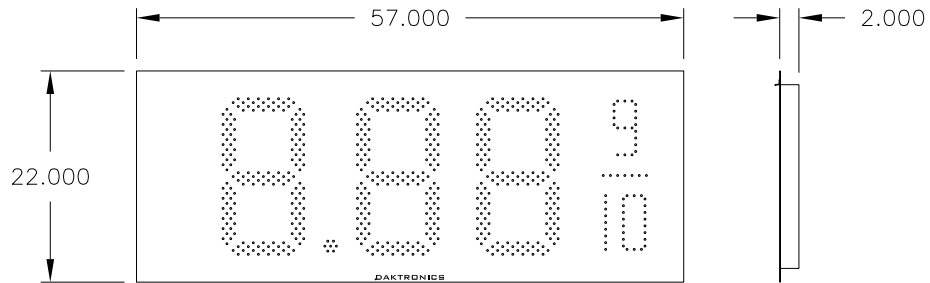

DF-2000-18-NA-DI

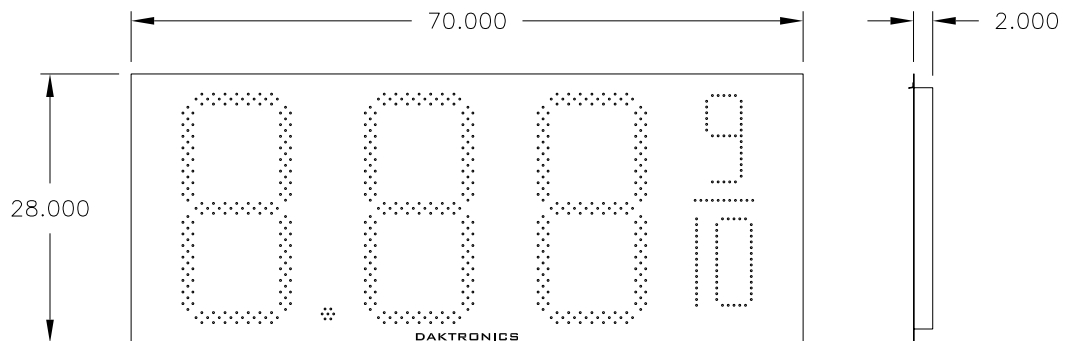

DF-2000-24-NA-DI

THE CONCEPTS EXPRESSED AND DETAILS SHOWN ON THIS DRAWING ARE CONFIDENTIAL AND PROPRIETARY. DO NOT REPRODUCE BY ANY MEANS, INCLUDING ELECTRONICALLY WITHOUT THE EXPRESSED WRITTEN CONSENT OF DAKTRONICS, INC. COPYRIGHT 2007 DAKTRONICS, INC.

DAKTRONICS, INC. BROOKINGS, SD 57006

PROJ: FUEL PRICING DISPLAYS

TITLE: DF-2000 DROP-IN MODELS

DES. BY: AVB

DRAWN BY: A VANBEMMEL

DATE: 15 JUN 07

REV.	DATE	DESCRIPTION	BY	APPR.
00				

REVISION

APPR. BY:

00

SCALE: 1=20

1356-R08A-308916

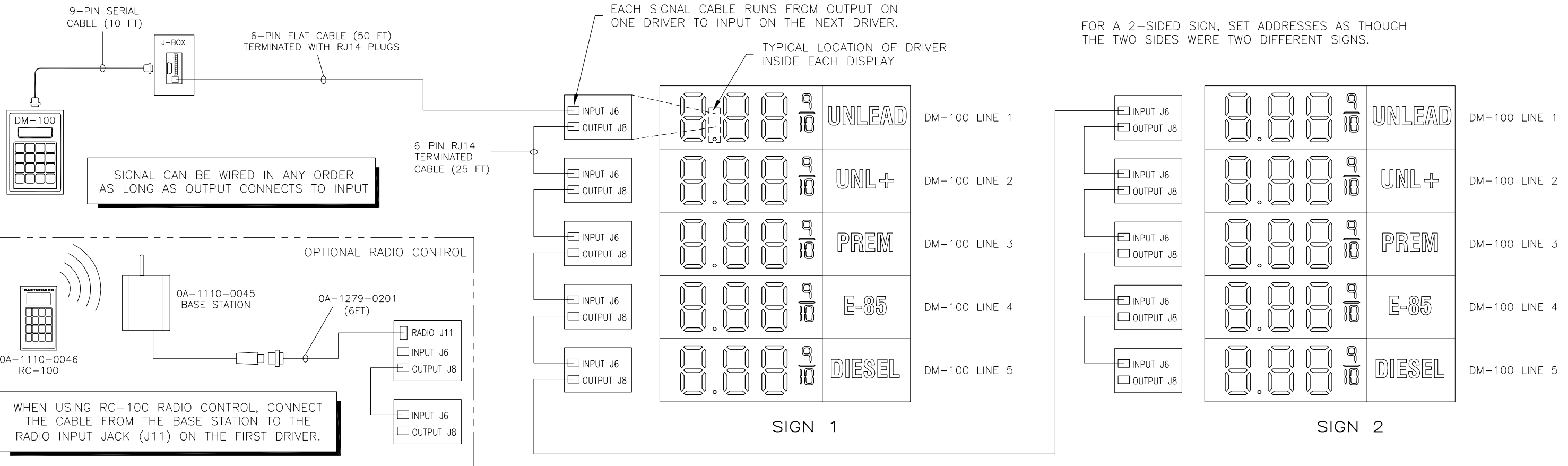

LINE NUMBER
SET LINE NUMBER USING ONE-OFFSET BINARY NOTATION.

LINE	BIT	SWITCH
LINE 1	OFF	SWITCH 1
	OFF	SWITCH 2
	OFF	SWITCH 3
LINE 2	ON	SWITCH 1
	OFF	SWITCH 2
	OFF	SWITCH 3
LINE 3	OFF	SWITCH 1
	ON	SWITCH 2
	OFF	SWITCH 3
LINE 4	ON	SWITCH 1
	ON	SWITCH 2
	OFF	SWITCH 3
LINE 5	OFF	SWITCH 1
	OFF	SWITCH 2
	ON	SWITCH 3
LINE 6	ON	SWITCH 1
	OFF	SWITCH 2
	ON	SWITCH 3
LINE 7	OFF	SWITCH 1
	ON	SWITCH 2
	ON	SWITCH 3
LINE 8	ON	SWITCH 1
	ON	SWITCH 2
	ON	SWITCH 3

SIGN NUMBER
SET SIGN NUMBER USING ONE-OFFSET BINARY NOTATION.

SIGN	BIT	SWITCH
SIGN 1	OFF	SWITCH 4
	OFF	SWITCH 5
	OFF	SWITCH 6
SIGN 2	ON	SWITCH 4
	OFF	SWITCH 5
	OFF	SWITCH 6
SIGN 3	OFF	SWITCH 4
	ON	SWITCH 5
	OFF	SWITCH 6
SIGN 4	ON	SWITCH 4
	ON	SWITCH 5
	OFF	SWITCH 6
SIGN 5	OFF	SWITCH 4
	OFF	SWITCH 5
	ON	SWITCH 6
SIGN 6	ON	SWITCH 4
	OFF	SWITCH 5
	ON	SWITCH 6
SIGN 7	OFF	SWITCH 4
	ON	SWITCH 5
	ON	SWITCH 6
SIGN 8	ON	SWITCH 4
	ON	SWITCH 5
	ON	SWITCH 6

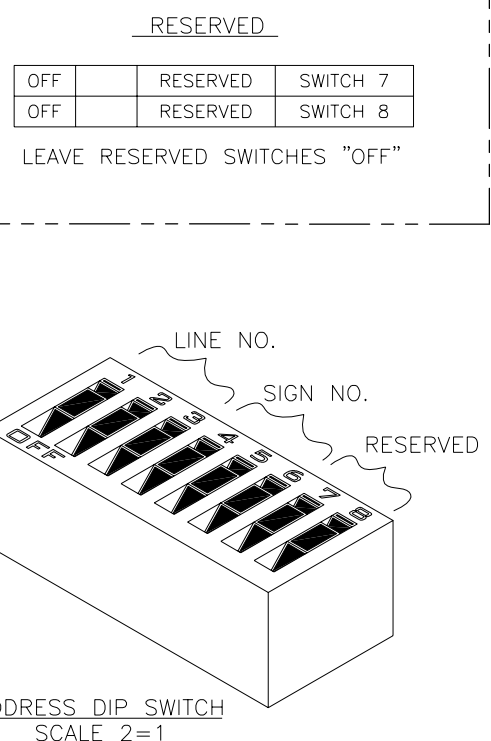

NOTES:

EVERY DRIVER MUST HAVE A UNIQUE ADDRESS.

THE ADDRESS IS SET BY FLIPPING THE SWITCHES IN AN 8 POSITION "DIP" SWITCH ON THE DRIVER, LOCATED IN EACH DISPLAY. A TYPICAL DRIVER IS SHOWN AT RIGHT.

THE DIP SWITCH IS SHOWN AT LEFT. ALL SWITCHES ARE SHOWN IN THE OFF POSITION IN THIS FIGURE.

THREE SWITCHES ARE USED TO SET THE LINE NUMBER, AND THREE SET THE SIGN NUMBER. TWO SWITCHES ARE NOT USED.

ADDRESSES ALLOW UP TO EIGHT SIGNS WITH UP TO EIGHT LINES EACH.

ALL DISPLAYS WITH THE SAME LINE NUMBER WILL SHOW THE SAME PRICE.

FOR A 2-SIDED SIGN, SET ADDRESSES AS THOUGH THE TWO SIDES WERE TWO DIFFERENT SIGNS.

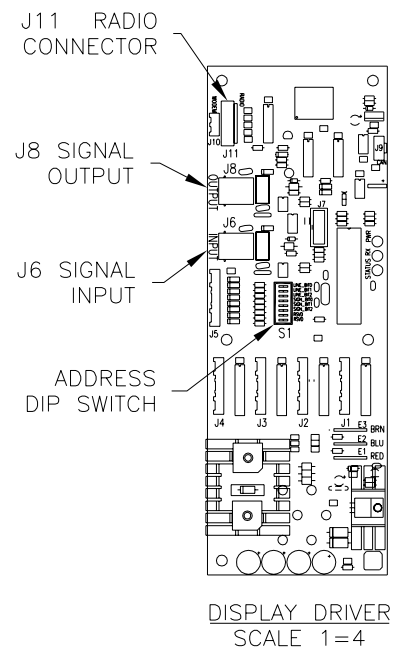

REV.	DATE	DESCRIPTION	BY	APPR.
03	09 JUN 06	ADDED NOTE ABOUT ADDRESSING 2-SIDED SIGNS.	AVB	
02	09 FEB 06	ADDED FIGURE FOR OPTIONAL RADIO CONTROL.	AVB	
01	28 DEC 05	ADDED DRIVER FIGURE. ADDED SOME NOTES.	AVB	

THE CONCEPTS EXPRESSED AND DETAILS SHOWN ON THIS DRAWING ARE CONFIDENTIAL AND PROPRIETARY. DO NOT REPRODUCE BY ANY MEANS, INCLUDING ELECTRONICALLY WITHOUT THE EXPRESSED WRITTEN CONSENT OF DAKTRONICS, INC. COPYRIGHT 2005 DAKTRONICS, INC.	
DAKTRONICS, INC. BROOKINGS, SD 57006	
PROJ: GAS PRICE DISPLAYS	
TITLE: ADDRESS DIP SWITCH SETTINGS	
DES. BY: THENDRI	DATE: 27 SEP 05
REVISION	APPR. BY:
03	SCALE: NONE

1356-R10B-256001

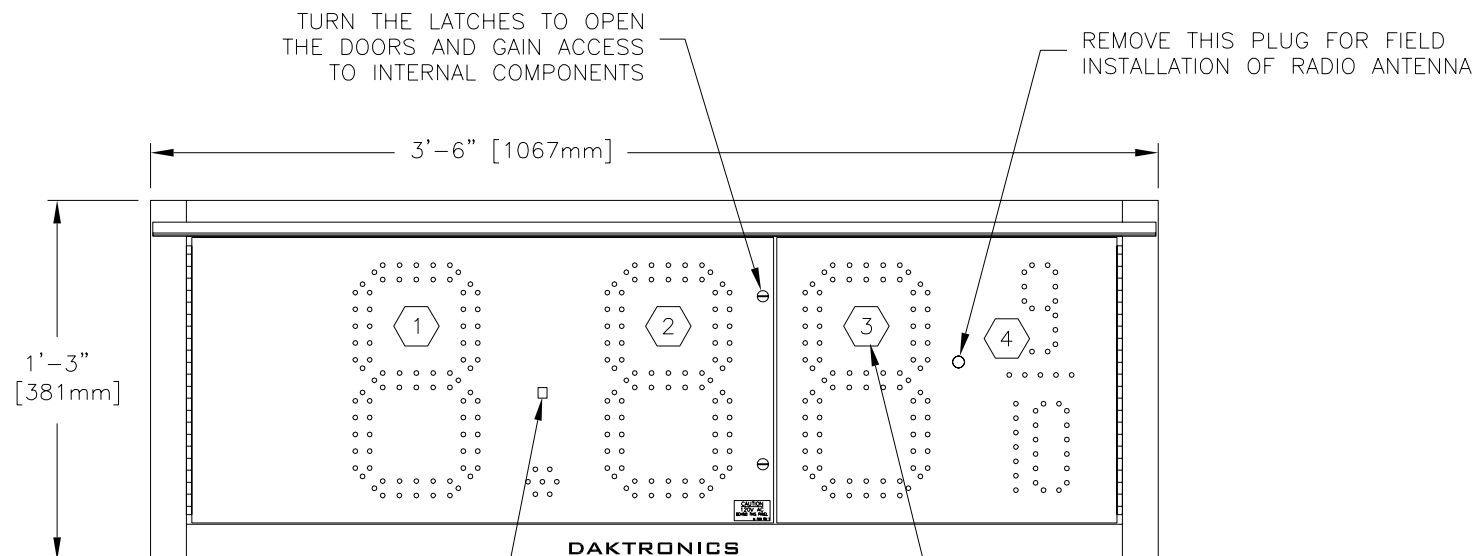

LIGHT SENSOR FOR AUTOMATIC DIMMING

FRONT VIEW

NUMBERS INDICATE WHICH DRIVER PLUG IS WIRED TO EACH DIGIT

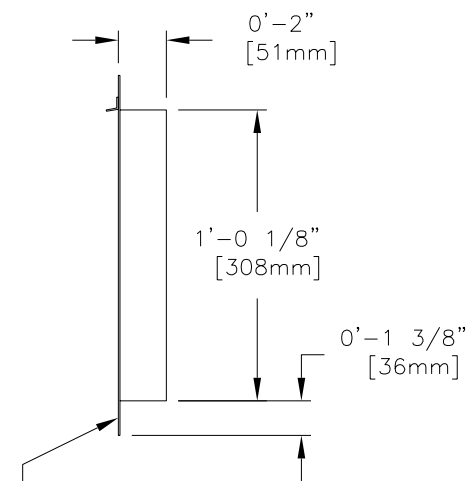

SIDE VIEW

DRILL THROUGH THE FLANGES TO MOUNT THE DISPLAY.

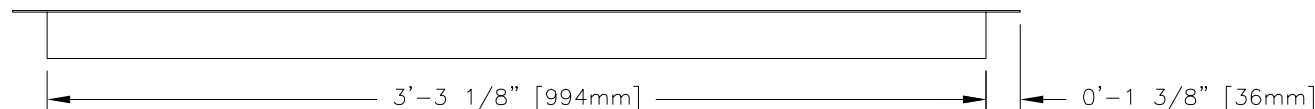

BOTTOM VIEW

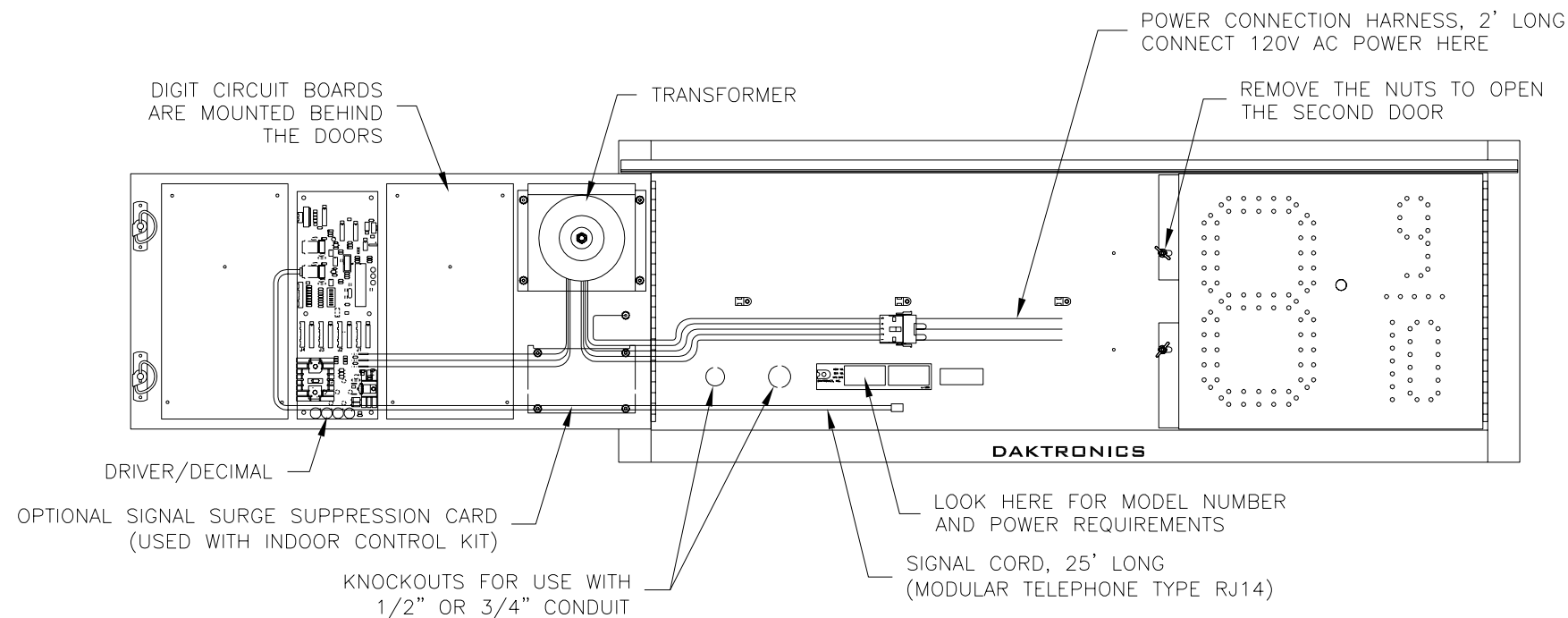

FRONT VIEW

WITH ONE DOOR OPEN (NOT ALL WIRES ARE SHOWN)

NOTES:

GENERAL

THIS IS A SINGLE FACED DROP-IN DISPLAY, INTENDED TO BE MOUNTED IN A RECTANGULAR OPENING IN A LARGER SIGN.

RECOMMENDED ROUGH OPENING DIMENSIONS: 39 5/8" X 12 5/8".

ALL DIGITS ARE 10" NOMINAL HEIGHT.

DIGIT LEDs MAY BE RED, AMBER, OR GREEN; TO BE SPECIFIED AT TIME OF ORDER.

MECHANICAL

CABINET IS CONSTRUCTED OF ALUMINUM SHEET, 0.063" THICK.

ESTIMATED WEIGHT IS ABOUT 25 LBS [11 KG].

DRILL THROUGH THE FLANGES OF THE CABINET TO ATTACH THE DISPLAY TO BASE STRUCTURE USING APPROPRIATE HARDWARE FOR THE SITE CONDITIONS.

DAKTRONICS IS NOT RESPONSIBLE FOR THE MOUNTING STRUCTURE OR FOR THE ADEQUACY OF ATTACHMENT TO THE STRUCTURE. STRUCTURE AND ATTACHMENT MUST CONFORM TO ALL APPLICABLE BUILDING CODES.

ELECTRICAL

MAXIMUM POWER DEMAND IS 75 WATTS.

PROVIDE A 120V AC, 15 AMP CIRCUIT FOR POWER.

SERVICE AND ELECTRICAL HOOKUP ACCESS IS THROUGH THE FRONT OF THE DISPLAY ONLY.

IF THE POWER TO THE DISPLAY IS TEMPORARILY DISRUPTED, DISPLAY FUNCTIONS WILL BE RETAINED IN MEMORY TO CONTINUE OPERATION WHEN POWER IS RESTORED.

THE CONCEPTS EXPRESSED AND DETAILS SHOWN ON THIS DRAWING ARE CONFIDENTIAL AND PROPRIETARY. DO NOT REPRODUCE BY ANY MEANS, INCLUDING ELECTRONICALLY WITHOUT THE EXPRESSED WRITTEN CONSENT OF DAKTRONICS, INC. COPYRIGHT 2005 DAKTRONICS, INC.

DAKTRONICS, INC. BROOKINGS, SD 57006

PROJ: GAS PRICE DISPLAYS

TITLE: SHOP DRAWING, DF-2000-10-NA-DI

DES. BY: DRAWN BY: M LEOPOLD DATE: 15 JAN 07

REVISION 00 APPR. BY: SCALE: 1=8

1356-R04B-294457

REV.	DATE	DESCRIPTION	BY	APPR.

REMOVE THIS PLUG FOR FIELD INSTALLATION OF RADIO ANTENNA

NUMBERS INDICATE WHICH DRIVER PLUG IS WIRED TO EACH DIGIT

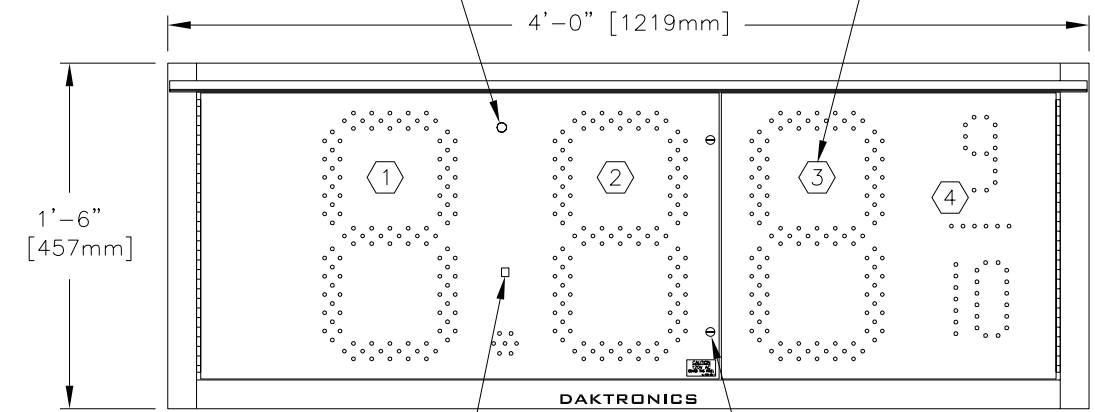

LIGHT SENSOR FOR AUTOMATIC DIMMING

TURN THE LATCHES TO OPEN THE DOORS AND GAIN ACCESS TO INTERNAL COMPONENTS

FRONT VIEW

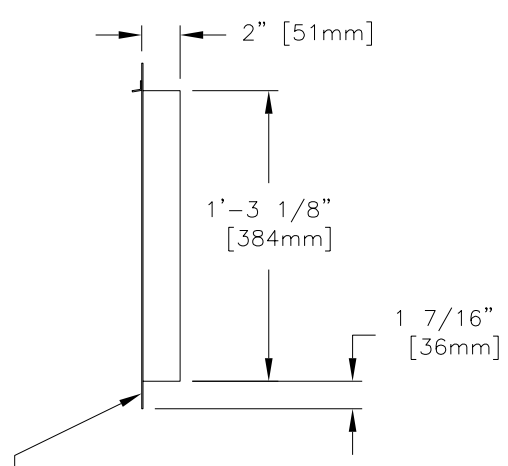

SIDE VIEW

DRILL THROUGH THE FLANGES TO MOUNT THE DISPLAY.



BOTTOM VIEW

NOTES:

GENERAL

THIS IS A SINGLE FACED DROP-IN DISPLAY, INTENDED TO BE MOUNTED IN A RECTANGULAR OPENING IN A LARGER SIGN.

RECOMMENDED ROUGH OPENING DIMENSIONS: 45 1/2" X 15 1/2" [1156 mm X 397 mm].

LARGE DIGITS ARE 13" NOMINAL HEIGHT. THE 9/10 DIGIT IS 12" NOMINAL HEIGHT.

DIGIT LEDs MAY BE RED, AMBER, OR GREEN; TO BE SPECIFIED AT TIME OF ORDER.

MECHANICAL

CABINET IS CONSTRUCTED OF ALUMINUM SHEET, 0.063" THICK.

ESTIMATED WEIGHT IS ABOUT 30 LBS [14 KGS].

DRILL THROUGH THE FLANGES OF THE CABINET TO ATTACH THE DISPLAY TO BASE STRUCTURE USING APPROPRIATE HARDWARE FOR THE SITE CONDITIONS.

DAKTRONICS IS NOT RESPONSIBLE FOR THE MOUNTING STRUCTURE OR FOR THE ADEQUACY OF ATTACHMENT TO THE STRUCTURE. STRUCTURE AND ATTACHMENT MUST CONFORM TO ALL APPLICABLE BUILDING CODES.

ELECTRICAL

MAXIMUM POWER DEMAND IS 75 WATTS.

PROVIDE A 120V AC, 15 AMP CIRCUIT FOR POWER.

SERVICE AND ELECTRICAL HOOKUP ACCESS IS THROUGH THE FRONT OF THE DISPLAY ONLY.

IF THE POWER TO THE DISPLAY IS TEMPORARILY INTERRUPTED, DISPLAY FUNCTIONS WILL BE RETAINED IN MEMORY TO CONTINUE OPERATION WHEN POWER IS RESTORED.

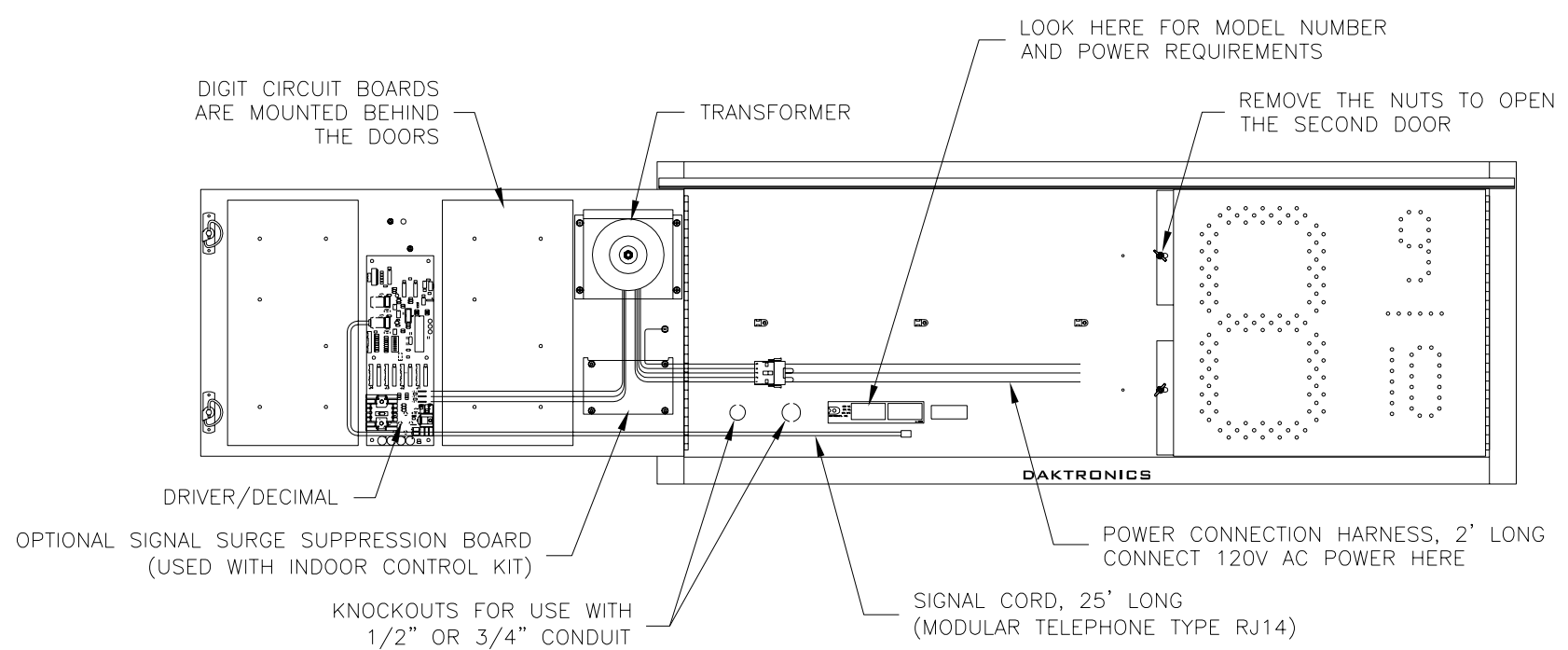

FRONT VIEW

WITH ONE DOOR OPEN (NOT ALL WIRES ARE SHOWN)

THE CONCEPTS EXPRESSED AND DETAILS SHOWN ON THIS DRAWING ARE CONFIDENTIAL AND PROPRIETARY. DO NOT REPRODUCE BY ANY MEANS, INCLUDING ELECTRONICALLY WITHOUT THE EXPRESSED WRITTEN CONSENT OF DAKTRONICS, INC. COPYRIGHT 2005 DAKTRONICS, INC.

DAKTRONICS, INC. BROOKINGS, SD 57006

PROJ: GAS PRICE DISPLAYS

TITLE: SHOP DRAWING, DF-2000-13-NA-DI

DES. BY: DRAWN BY: M LEOPOLD DATE: 17 JAN 07

REVISION 00 APPR. BY: SCALE: 1=10 1356-R04B-294734

REV.	DATE	DESCRIPTION	BY	APPR.

REMOVE THIS PLUG FOR FIELD INSTALLATION OF RADIO ANTENNA

TURN THE LATCHES TO OPEN THE DOORS AND GAIN ACCESS TO INTERNAL COMPONENTS

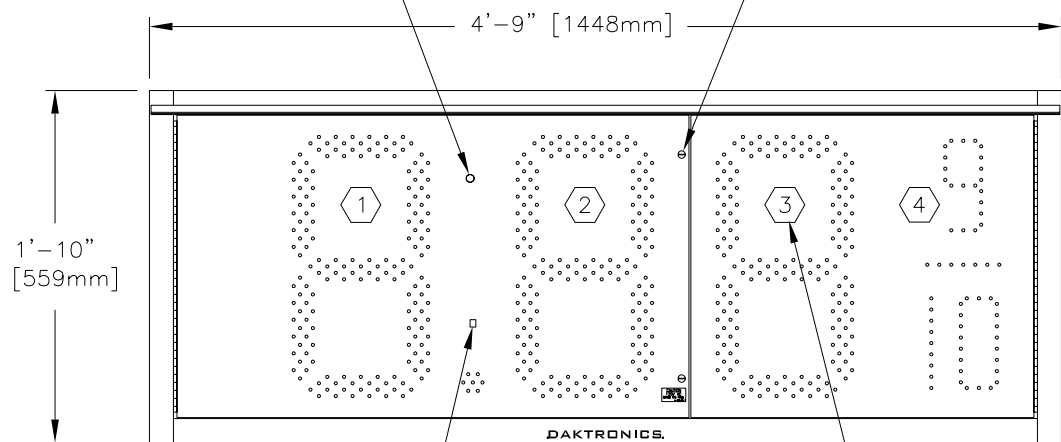

LIGHT SENSOR FOR AUTOMATIC DIMMING

FRONT VIEW

NUMBERS INDICATE WHICH DRIVER PLUG IS WIRED TO EACH DIGIT

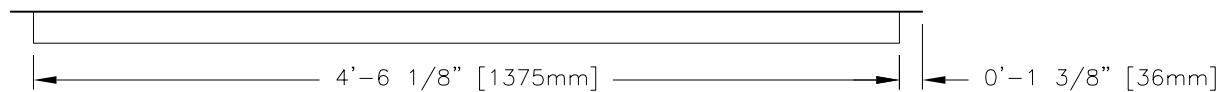

BOTTOM VIEW

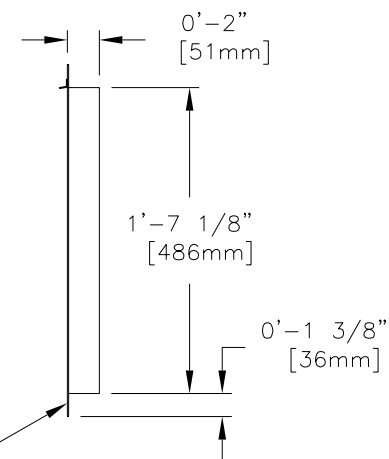

SIDE VIEW

DRILL THROUGH THE FLANGES TO MOUNT THE DISPLAY.

NOTES:

GENERAL

THIS IS A SINGLE FACED DROP-IN DISPLAY, INTENDED TO BE MOUNTED IN A RECTANGULAR OPENING IN A LARGER SIGN.

RECOMMENDED ROUGH OPENING DIMENSIONS: 54 5/8" X 19 5/8".

LARGE DIGITS ARE 18" NOMINAL HEIGHT. THE 9/10 DIGIT IS 16" NOMINAL HEIGHT.

DIGIT LEDS MAY BE RED, AMBER, OR GREEN; TO BE SPECIFIED AT TIME OF ORDER.

MECHANICAL

CABINET IS CONSTRUCTED OF ALUMINUM SHEET, 0.063" THICK.

ESTIMATED WEIGHT IS ABOUT 30 LBS [14 KGS].

DRILL THROUGH THE FLANGES OF THE CABINET TO ATTACH THE DISPLAY TO BASE STRUCTURE USING APPROPRIATE HARDWARE FOR THE SITE CONDITIONS.

DAKTRONICS IS NOT RESPONSIBLE FOR THE MOUNTING STRUCTURE OR FOR THE ADEQUACY OF ATTACHMENT TO THE STRUCTURE. STRUCTURE AND ATTACHMENT MUST CONFORM TO ALL APPLICABLE BUILDING CODES.

ELECTRICAL

MAXIMUM POWER DEMAND IS 75 WATTS FOR DISPLAYS WITH RED OR AMBER DIGITS, OR 150 WATTS FOR DISPLAYS WITH GREEN DIGITS.

PROVIDE A 120V AC, 15 AMP CIRCUIT FOR POWER.

SERVICE AND ELECTRICAL HOOKUP ACCESS IS THROUGH THE FRONT OF THE DISPLAY ONLY.

IF THE POWER TO THE DISPLAY IS TEMPORARILY INTERRUPTED, DISPLAY FUNCTIONS WILL BE RETAINED IN MEMORY TO CONTINUE OPERATION WHEN POWER IS RESTORED.

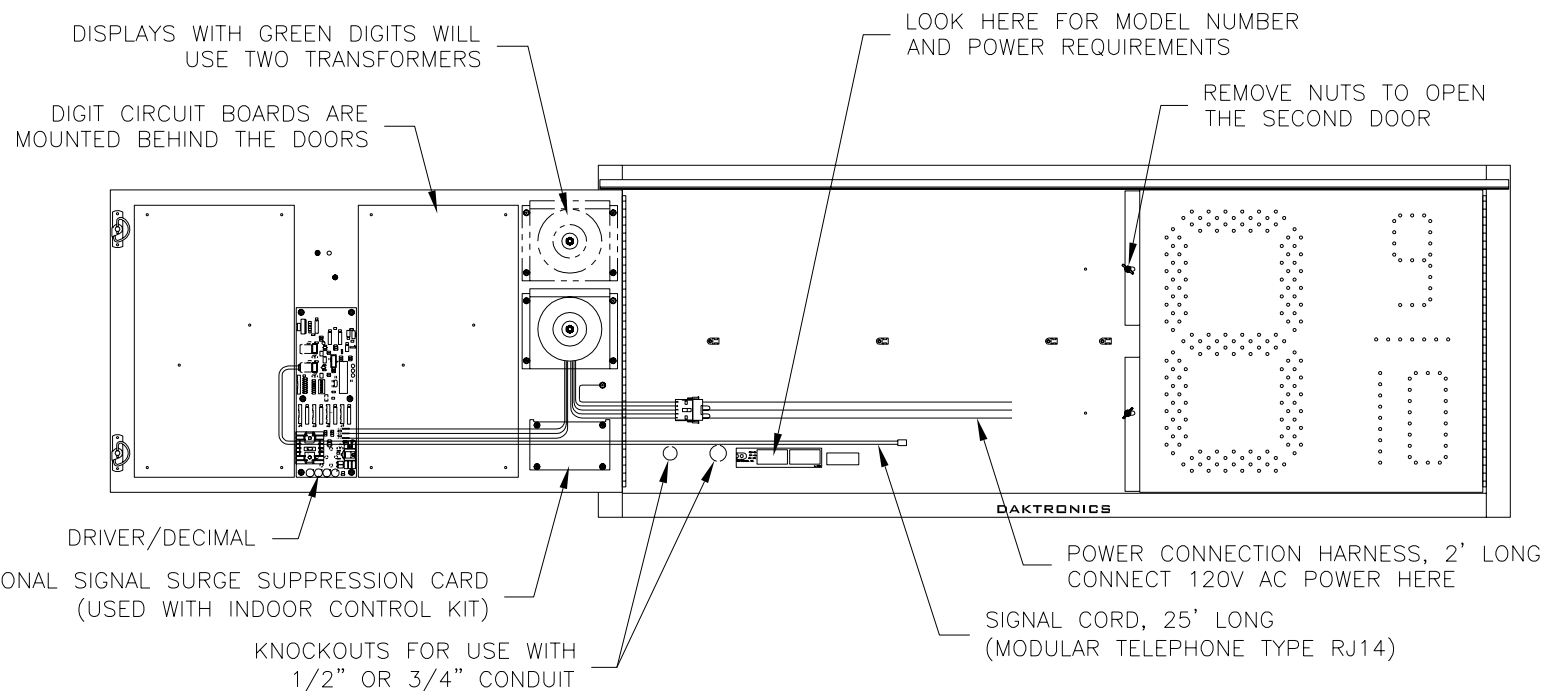

FRONT VIEW
WITH ONE DOOR OPEN
(NOT ALL WIRES ARE SHOWN)

THE CONCEPTS EXPRESSED AND DETAILS SHOWN ON THIS DRAWING ARE CONFIDENTIAL AND PROPRIETARY. DO NOT REPRODUCE BY ANY MEANS, INCLUDING ELECTRONICALLY WITHOUT THE EXPRESSED WRITTEN CONSENT OF DAKTRONICS, INC. COPYRIGHT 2005 DAKTRONICS, INC.

DAKTRONICS, INC. BROOKINGS, SD 57006

PROJ: GAS PRICE DISPLAYS

TITLE: SHOP DRAWING, DF-2000-18-NA-DI

DES. BY: DRAWN BY: M LEOPOLD DATE: 17 JAN 07

REVISION 00 APPR. BY: SCALE: 1=12 1356-R04B-294758

REV.	DATE	DESCRIPTION	BY	APPR.

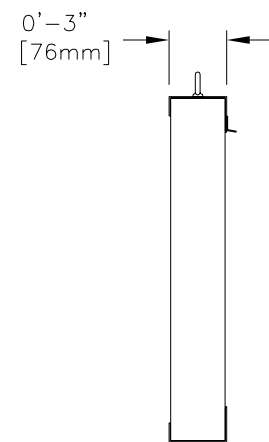

SIDE VIEW

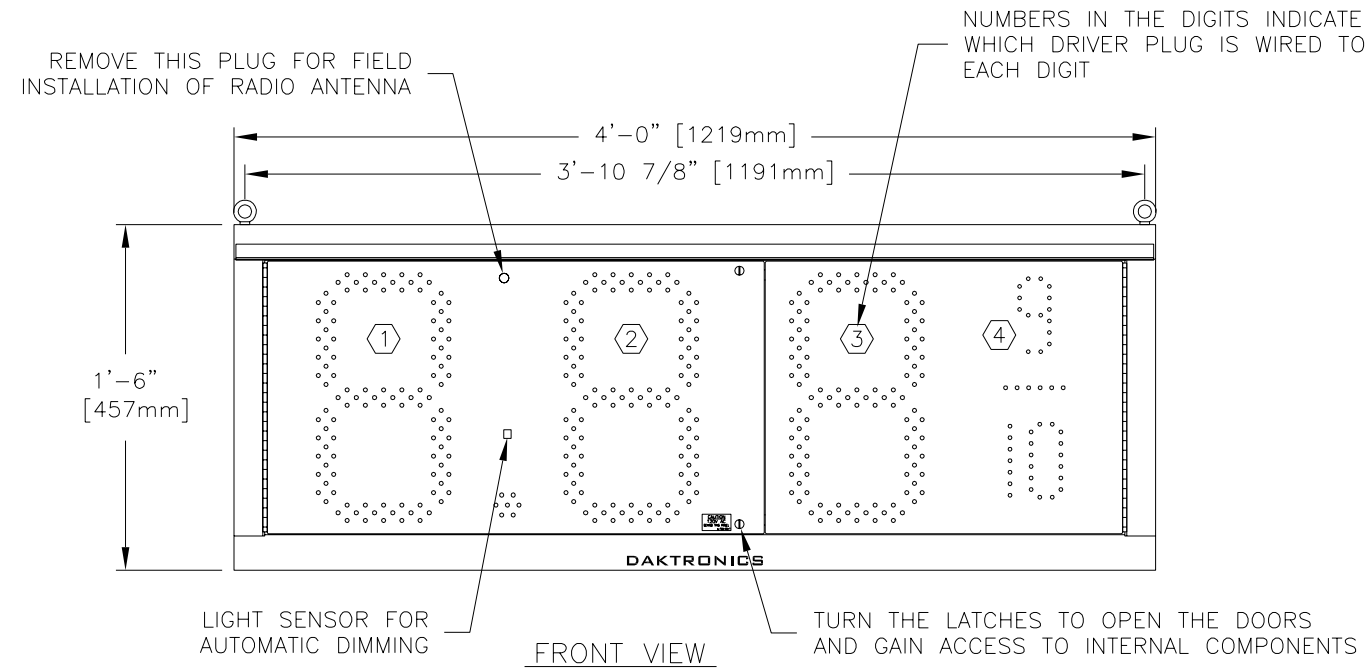

FRONT VIEW

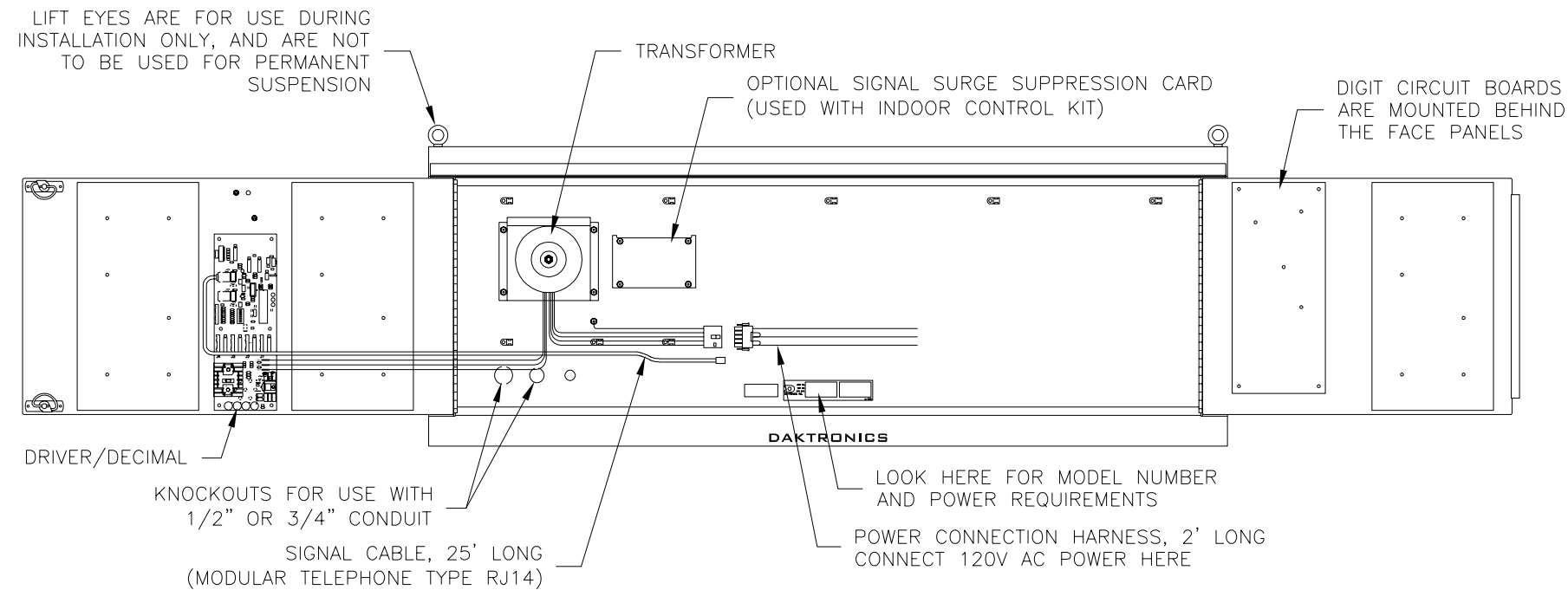

FRONT VIEW
WITH BOTH DOORS OPEN
(NOT ALL WIRES ARE SHOWN)

NOTES:

GENERAL

DIGITS ARE 13" NOMINAL HEIGHT. THE 9/10 DIGIT IS 12" NOMINAL HEIGHT. DIGIT LEDS MAY BE RED, AMBER, OR GREEN; TO BE SPECIFIED AT TIME OF ORDER.

MECHANICAL

CABINET IS CONSTRUCTED OF ALUMINUM SHEET, 0.063" THICK.

ESTIMATED WEIGHT IS ABOUT 30 LBS [14 KG].

IF THE EYEBOLTS ARE TO BE REMOVED AFTER INSTALLATION, PLUG HOLES BY THREADING IN 1/4"-20 BOLTS, NOT PROVIDED.

DRILL THROUGH THE SIDES OR BACK OF THE CABINET TO ATTACH THE DISPLAY TO BASE STRUCTURE USING APPROPRIATE HARDWARE FOR THE SITE CONDITIONS.

DAKTRONICS IS NOT RESPONSIBLE FOR THE MOUNTING STRUCTURE OR FOR THE ADEQUACY OF ATTACHMENT TO THE STRUCTURE. STRUCTURE AND ATTACHMENT MUST CONFORM TO ALL APPLICABLE BUILDING CODES.

ELECTRICAL

MAXIMUM POWER CONSUMPTION IS ABOUT 75 WATTS.

PROVIDE A 120V AC, 15 AMP CIRCUIT FOR POWER.

CONTROL CONNECTION REQUIRES 3-PAIR CABLE, 22 AWG.

SERVICE AND ELECTRICAL HOOKUP ACCESS IS THROUGH THE FRONT OF THE DISPLAY ONLY. KNOCKOUTS ARE PROVIDED IN THE BACK OF THE CABINET FOR ROUTING OF POWER AND SIGNAL WIRES.

IF THE POWER TO THE DISPLAY IS TEMPORARILY INTERRUPTED, DISPLAY FUNCTIONS WILL BE RETAINED IN MEMORY TO CONTINUE OPERATION WHEN POWER IS RESTORED.

THE CONCEPTS EXPRESSED AND DETAILS SHOWN ON THIS DRAWING ARE CONFIDENTIAL AND PROPRIETARY. DO NOT REPRODUCE BY ANY MEANS, INCLUDING ELECTRONICALLY WITHOUT THE EXPRESSED WRITTEN CONSENT OF DAKTRONICS, INC. COPYRIGHT 2006 DAKTRONICS, INC.

DAKTRONICS, INC. BROOKINGS, SD 57006

PROJ: GAS PRICE DISPLAYS

TITLE: SHOP DRAWING, DF-2000-13-NA-SF

DES. BY: DRAWN BY: M LEOPOLD DATE: 19 JAN 07

REVISION 00 APPR. BY: SCALE: 1=10 1356-R04B-294987

REV.	DATE	DESCRIPTION	BY	APPR.

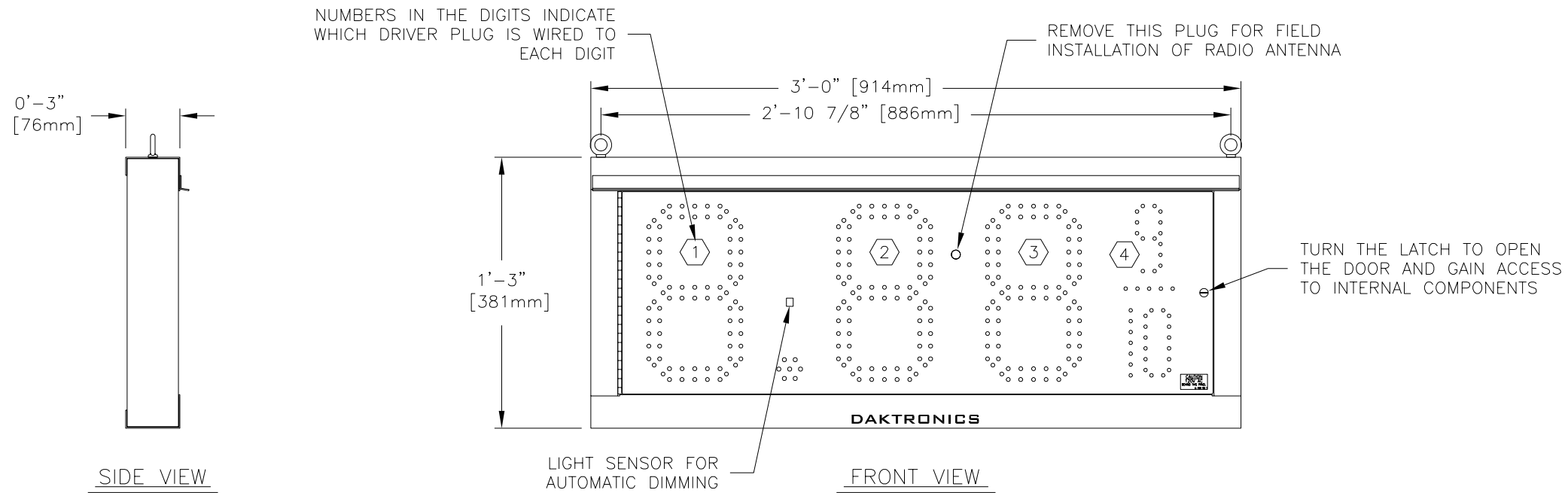

SIDE VIEW

FRONT VIEW

NOTES:

GENERAL

DIGITS ARE 10" NOMINAL HEIGHT. DIGIT LEDS MAY BE RED, AMBER, OR GREEN; TO BE SPECIFIED AT TIME OF ORDER.

MECHANICAL

CABINET IS CONSTRUCTED OF ALUMINUM SHEET, 0.063" THICK.

ESTIMATED WEIGHT IS ABOUT 25 LBS [11 KG].

IF THE EYEBOLTS ARE TO BE REMOVED AFTER INSTALLATION, PLUG HOLES BY THREADING IN 1/4"-20 BOLTS, NOT PROVIDED.

DRILL THROUGH THE SIDES OR BACK OF THE CABINET TO ATTACH THE DISPLAY TO BASE STRUCTURE USING APPROPRIATE HARDWARE FOR THE SITE CONDITIONS.

DAKTRONICS IS NOT RESPONSIBLE FOR THE MOUNTING STRUCTURE OR FOR THE ADEQUACY OF ATTACHMENT TO THE STRUCTURE. STRUCTURE AND ATTACHMENT MUST CONFORM TO ALL APPLICABLE BUILDING CODES.

ELECTRICAL

MAXIMUM POWER CONSUMPTION IS ABOUT 75 WATTS.

PROVIDE A 120V AC, 15 AMP CIRCUIT FOR POWER.

CONTROL CONNECTION REQUIRES 3-PAIR CABLE, 22 AWG.

SERVICE AND ELECTRICAL HOOKUP ACCESS IS THROUGH THE FRONT OF THE DISPLAY ONLY. KNOCKOUTS ARE PROVIDED IN THE BACK OF THE CABINET FOR ROUTING OF POWER AND SIGNAL WIRES.

IF THE POWER TO THE DISPLAY IS TEMPORARILY INTERRUPTED, DISPLAY FUNCTIONS WILL BE RETAINED IN MEMORY TO CONTINUE OPERATION WHEN POWER IS RESTORED.

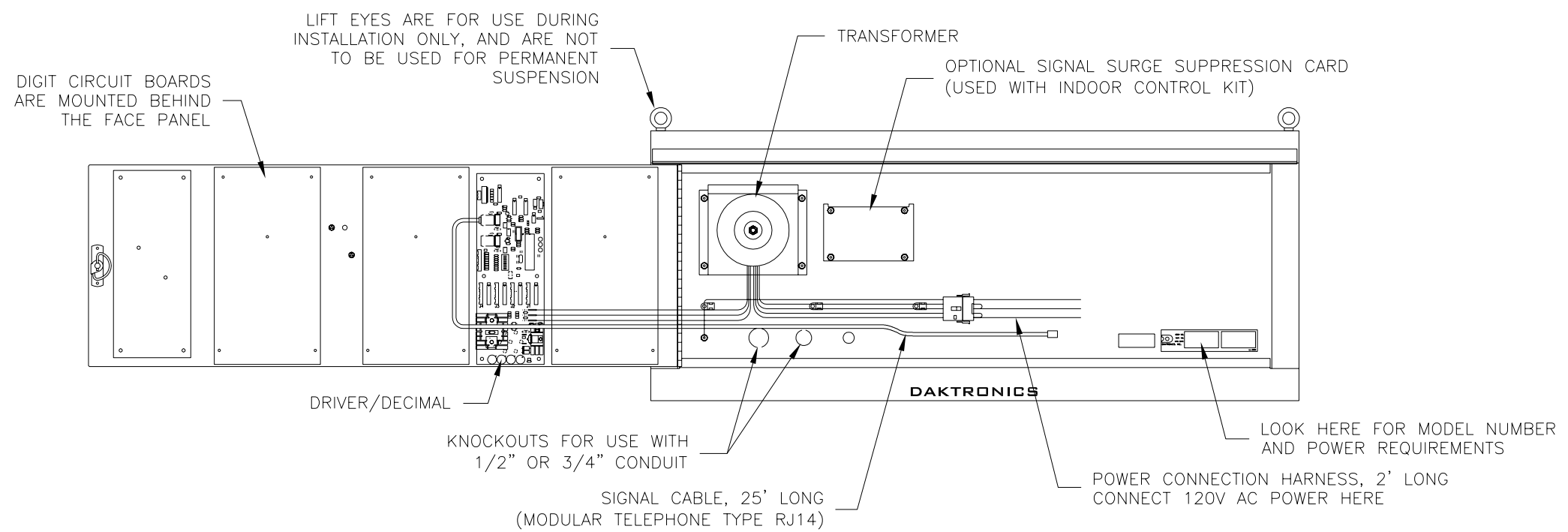

FRONT VIEW
WITH DOOR OPEN
(NOT ALL WIRES ARE SHOWN)

THE CONCEPTS EXPRESSED AND DETAILS SHOWN ON THIS DRAWING ARE CONFIDENTIAL AND PROPRIETARY. DO NOT REPRODUCE BY ANY MEANS, INCLUDING ELECTRONICALLY WITHOUT THE EXPRESSED WRITTEN CONSENT OF DAKTRONICS, INC. COPYRIGHT 2006 DAKTRONICS, INC.

DAKTRONICS, INC. BROOKINGS, SD 57006

PROJ: GAS PRICE DISPLAYS

TITLE: SHOP DRAWING, DF-2000-10-NA-SF

DES. BY: DRAWN BY: M LEOPOLD DATE: 26 JAN 07

REVISION 00 APPR. BY: SCALE: 1=8 1356-R04B-295518

REV.	DATE	DESCRIPTION	BY	APPR.

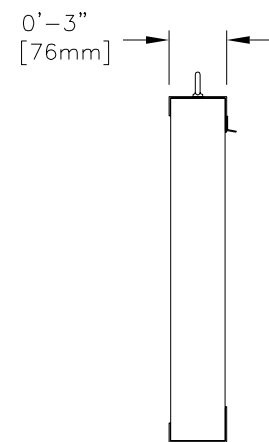

SIDE VIEW

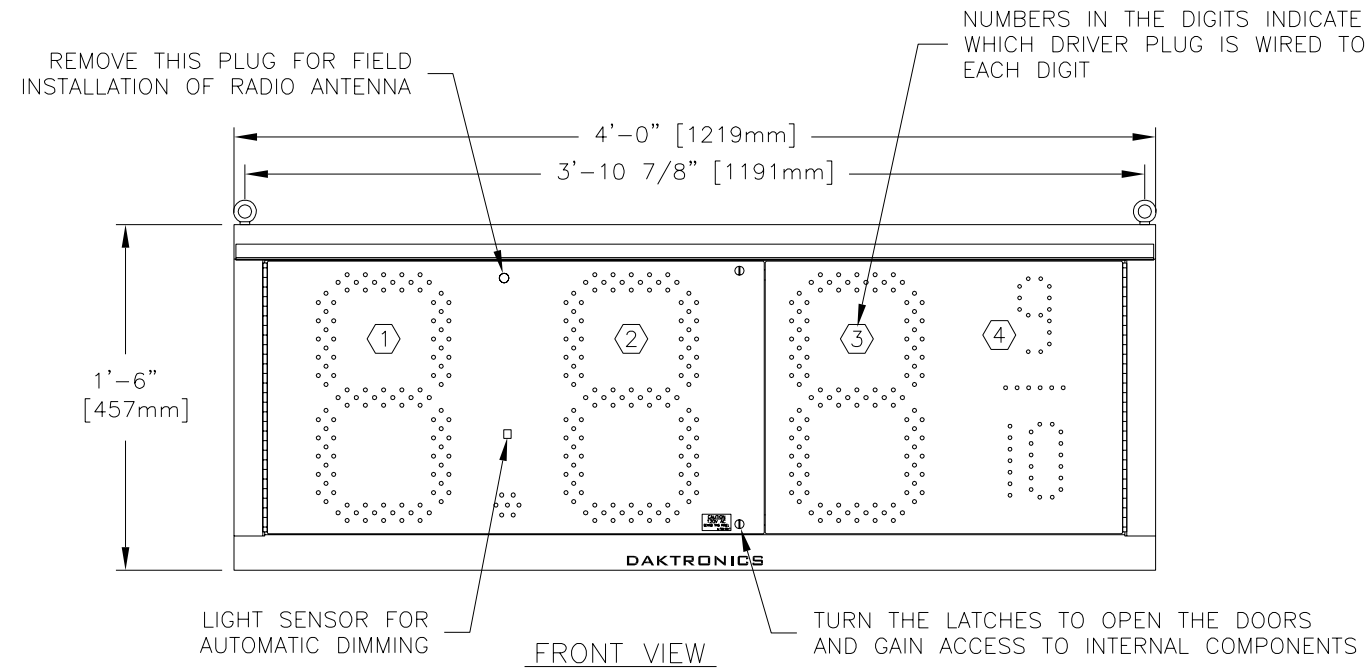

FRONT VIEW

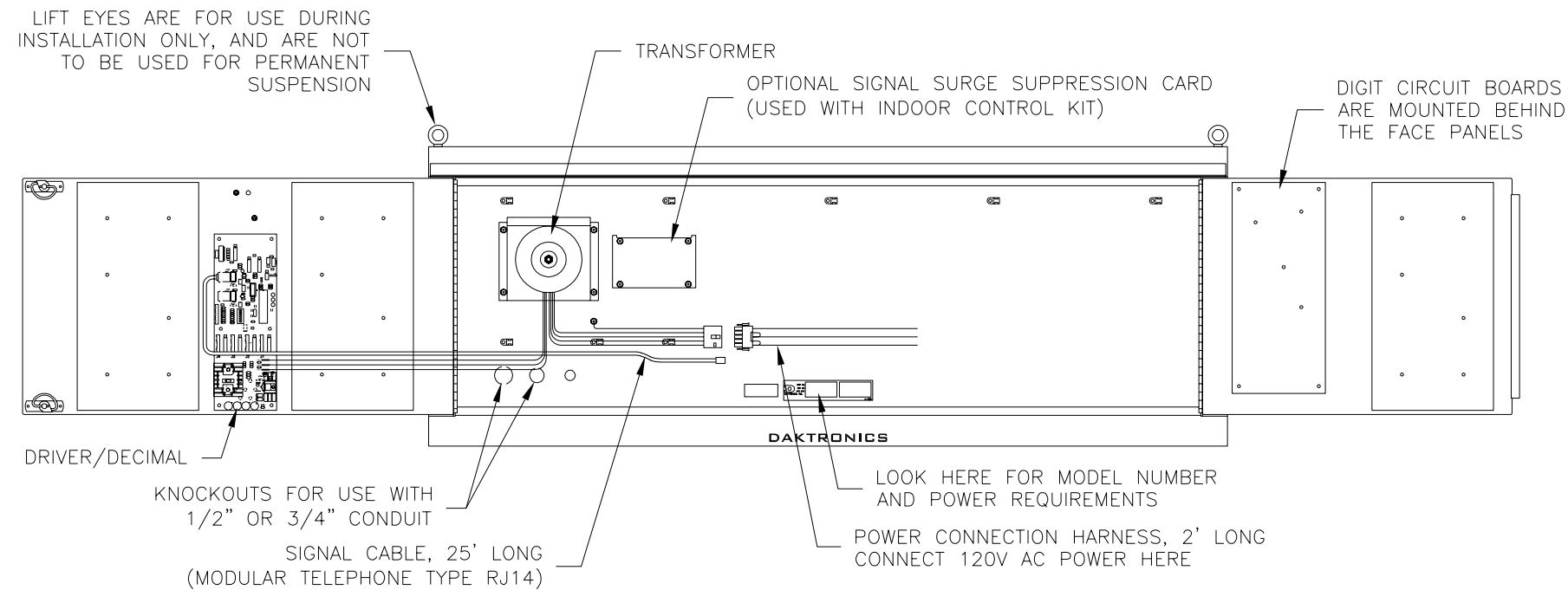

FRONT VIEW
WITH BOTH DOORS OPEN
(NOT ALL WIRES ARE SHOWN)

NOTES:

GENERAL

DIGITS ARE 13" NOMINAL HEIGHT. THE 9/10 DIGIT IS 12" NOMINAL HEIGHT. DIGIT LEDS MAY BE RED, AMBER, OR GREEN; TO BE SPECIFIED AT TIME OF ORDER.

MECHANICAL

CABINET IS CONSTRUCTED OF ALUMINUM SHEET, 0.063" THICK.

ESTIMATED WEIGHT IS ABOUT 30 LBS [14 KG].

IF THE EYEBOLTS ARE TO BE REMOVED AFTER INSTALLATION, PLUG HOLES BY THREADING IN 1/4"-20 BOLTS, NOT PROVIDED.

DRILL THROUGH THE SIDES OR BACK OF THE CABINET TO ATTACH THE DISPLAY TO BASE STRUCTURE USING APPROPRIATE HARDWARE FOR THE SITE CONDITIONS.

DAKTRONICS IS NOT RESPONSIBLE FOR THE MOUNTING STRUCTURE OR FOR THE ADEQUACY OF ATTACHMENT TO THE STRUCTURE. STRUCTURE AND ATTACHMENT MUST CONFORM TO ALL APPLICABLE BUILDING CODES.

ELECTRICAL

MAXIMUM POWER CONSUMPTION IS ABOUT 75 WATTS.

PROVIDE A 120V AC, 15 AMP CIRCUIT FOR POWER.

CONTROL CONNECTION REQUIRES 3-PAIR CABLE, 22 AWG.

SERVICE AND ELECTRICAL HOOKUP ACCESS IS THROUGH THE FRONT OF THE DISPLAY ONLY. KNOCKOUTS ARE PROVIDED IN THE BACK OF THE CABINET FOR ROUTING OF POWER AND SIGNAL WIRES.

IF THE POWER TO THE DISPLAY IS TEMPORARILY INTERRUPTED, DISPLAY FUNCTIONS WILL BE RETAINED IN MEMORY TO CONTINUE OPERATION WHEN POWER IS RESTORED.

THE CONCEPTS EXPRESSED AND DETAILS SHOWN ON THIS DRAWING ARE CONFIDENTIAL AND PROPRIETARY. DO NOT REPRODUCE BY ANY MEANS, INCLUDING ELECTRONICALLY WITHOUT THE EXPRESSED WRITTEN CONSENT OF DAKTRONICS, INC. COPYRIGHT 2006 DAKTRONICS, INC.

DAKTRONICS, INC. BROOKINGS, SD 57006

PROJ: GAS PRICE DISPLAYS

TITLE: SHOP DRAWING, DF-2000-13-NA-SF

DES. BY: DRAWN BY: M LEOPOLD DATE: 19 JAN 07

REVISION 00 APPR. BY: SCALE: 1=10 1356-R04B-294987

REV.	DATE	DESCRIPTION	BY	APPR.

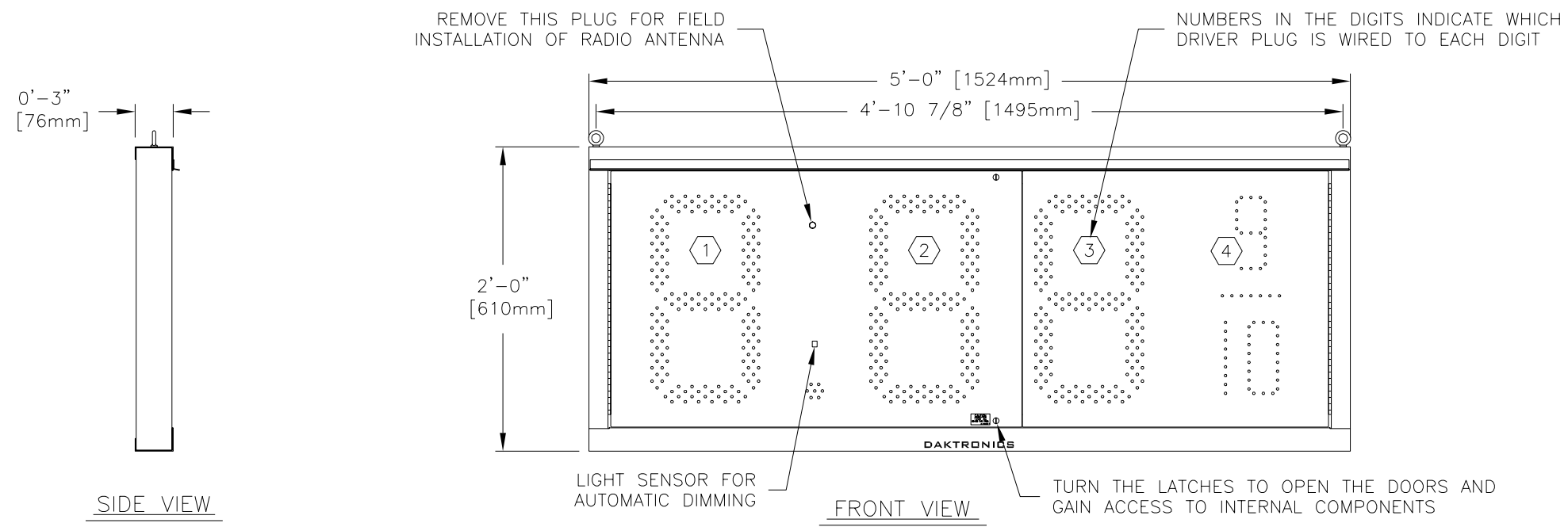

SIDE VIEW

FRONT VIEW

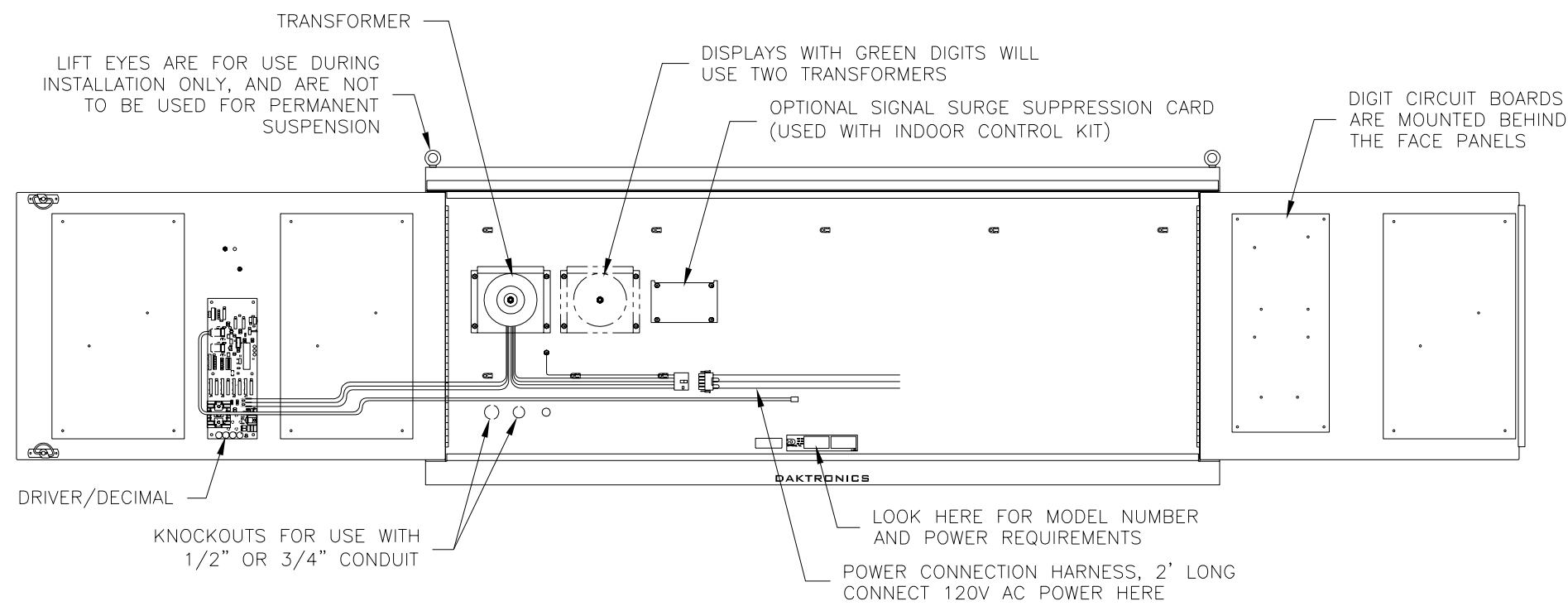

FRONT VIEW

WITH BOTH DOORS OPEN
(NOT ALL WIRES ARE SHOWN)

NOTES:

GENERAL

DIGITS ARE 18" NOMINAL HEIGHT. THE 9/10 DIGIT IS 16" NOMINAL HEIGHT. DIGIT LEDS MAY BE RED, AMBER, OR GREEN; TO BE SPECIFIED AT TIME OF ORDER.

MECHANICAL

CABINET IS CONSTRUCTED OF ALUMINUM SHEET, 0.063" THICK.

ESTIMATED WEIGHT IS ABOUT 35 LBS [16 KG].

IF THE EYEBOLTS ARE TO BE REMOVED AFTER INSTALLATION, PLUG HOLES BY THREADING IN 1/4"-20 BOLTS, NOT PROVIDED.

DRILL THROUGH THE SIDES OR BACK OF THE CABINET TO ATTACH THE DISPLAY TO BASE STRUCTURE USING APPROPRIATE HARDWARE FOR THE SITE CONDITIONS.

DAKTRONICS IS NOT RESPONSIBLE FOR THE MOUNTING STRUCTURE OR FOR THE ADEQUACY OF ATTACHMENT TO THE STRUCTURE. STRUCTURE AND ATTACHMENT MUST CONFORM TO ALL APPLICABLE BUILDING CODES.

ELECTRICAL

MAXIMUM POWER DEMAND IS 75 WATTS FOR DISPLAYS WITH RED OR AMBER DIGITS, OR 150 WATTS FOR DISPLAYS WITH GREEN DIGITS.

PROVIDE A 120V AC, 15 AMP CIRCUIT FOR POWER.

CONTROL CONNECTION REQUIRES 3-PAIR CABLE, 22 AWG.

SERVICE AND ELECTRICAL HOOKUP ACCESS IS THROUGH THE FRONT OF THE DISPLAY ONLY. KNOCKOUTS ARE PROVIDED IN THE BACK OF THE CABINET FOR ROUTING OF POWER AND SIGNAL WIRES.

IF THE POWER TO THE DISPLAY IS TEMPORARILY INTERRUPTED, DISPLAY FUNCTIONS WILL BE RETAINED IN MEMORY TO CONTINUE OPERATION WHEN POWER IS RESTORED.

THE CONCEPTS EXPRESSED AND DETAILS SHOWN ON THIS DRAWING ARE CONFIDENTIAL AND PROPRIETARY. DO NOT REPRODUCE BY ANY MEANS, INCLUDING ELECTRONICALLY WITHOUT THE EXPRESSED WRITTEN CONSENT OF DAKTRONICS, INC. COPYRIGHT 2006 DAKTRONICS, INC.

DAKTRONICS, INC. BROOKINGS, SD 57006

PROJ: GAS PRICE DISPLAYS

TITLE: SHOP DRAWING, DF-2000-18-NA-SF

DES. BY: DRAWN BY: M LEOPOLD DATE: 24 JAN 07

REVISION 00 APPR. BY: SCALE: 1=12 1356-R04B-295355

REV.	DATE	DESCRIPTION	BY	APPR.

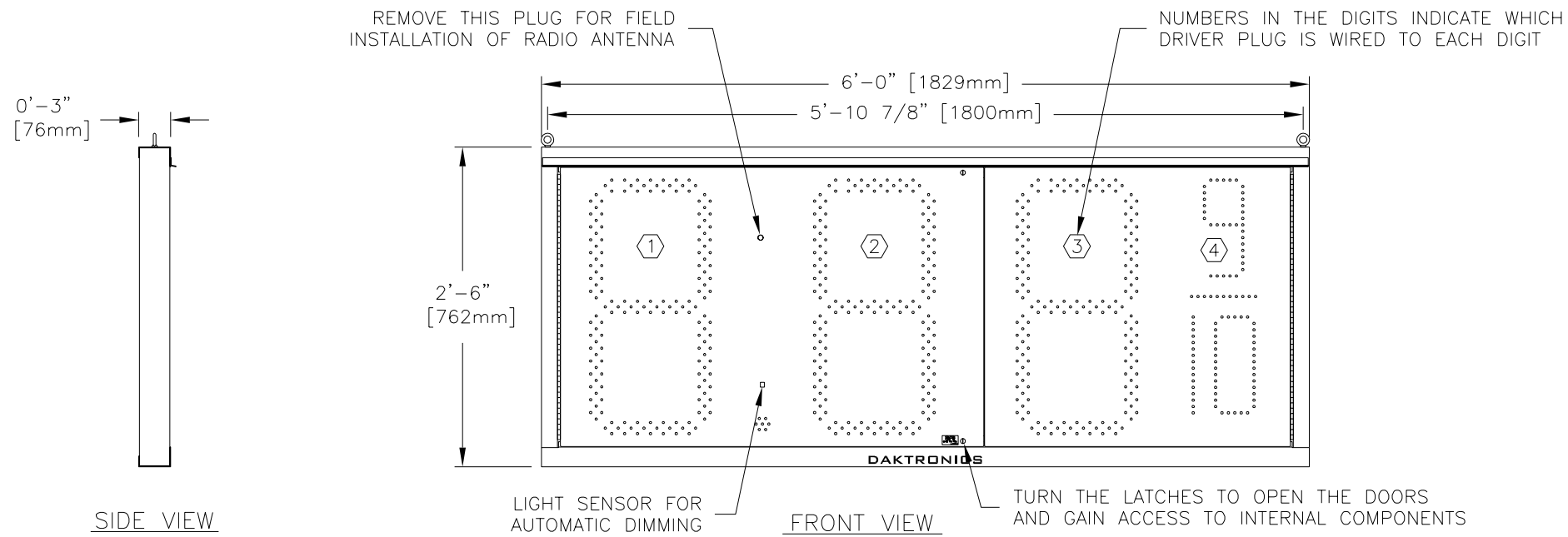

SIDE VIEW

FRONT VIEW

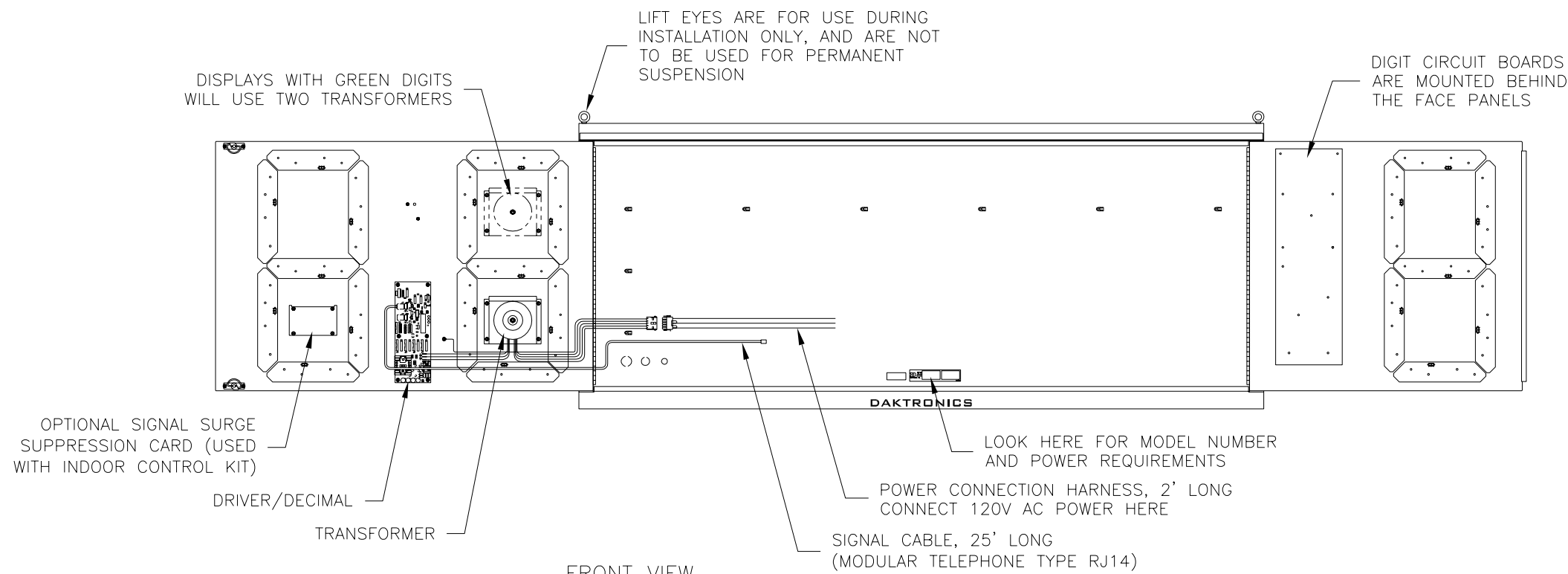

FRONT VIEW

WITH BOTH DOORS OPEN
(NOT ALL WIRES ARE SHOWN)

NOTES:

GENERAL

DIGITS ARE 24" NOMINAL HEIGHT. THE 9/10 DIGIT IS 22" IN HEIGHT. DIGIT LEDS MAY BE RED, AMBER, OR GREEN; TO BE SPECIFIED AT TIME OF ORDER.

MECHANICAL

CABINET IS CONSTRUCTED OF ALUMINUM SHEET, 0.063" THICK.

ESTIMATED WEIGHT IS ABOUT 40 LBS [18 KG].

IF THE EYEBOLTS ARE TO BE REMOVED AFTER INSTALLATION, PLUG HOLES BY THREADING IN 1/4"-20 BOLTS, NOT PROVIDED.

DRILL THROUGH THE SIDES OR BACK OF THE CABINET TO ATTACH THE DISPLAY TO BASE STRUCTURE USING APPROPRIATE HARDWARE FOR THE SITE CONDITIONS.

DAKTRONICS IS NOT RESPONSIBLE FOR THE MOUNTING STRUCTURE OR FOR THE ADEQUACY OF ATTACHMENT TO THE STRUCTURE. STRUCTURE AND ATTACHMENT MUST CONFORM TO ALL APPLICABLE BUILDING CODES.

ELECTRICAL

MAXIMUM POWER DEMAND IS 75 WATTS FOR DISPLAYS WITH RED OR AMBER DIGITS, OR 150 WATTS FOR DISPLAYS WITH GREEN DIGITS.

PROVIDE A 120V AC, 15 AMP CIRCUIT FOR POWER.

CONTROL CONNECTION REQUIRES 3-PAIR CABLE, 22 AWG.

SERVICE AND ELECTRICAL HOOKUP ACCESS IS THROUGH THE FRONT OF THE DISPLAY ONLY. KNOCKOUTS ARE PROVIDED IN THE BACK OF THE CABINET FOR ROUTING OF POWER AND SIGNAL WIRES.

IF THE POWER TO THE DISPLAY IS TEMPORARILY INTERRUPTED, DISPLAY FUNCTIONS WILL BE RETAINED IN MEMORY TO CONTINUE OPERATION WHEN POWER IS RESTORED.

THE CONCEPTS EXPRESSED AND DETAILS SHOWN ON THIS DRAWING ARE CONFIDENTIAL AND PROPRIETARY. DO NOT REPRODUCE BY ANY MEANS, INCLUDING ELECTRONICALLY WITHOUT THE EXPRESSED WRITTEN CONSENT OF DAKTRONICS, INC. COPYRIGHT 2006 DAKTRONICS, INC.

DAKTRONICS, INC. BROOKINGS, SD 57006

PROJ: GAS PRICE DISPLAYS

TITLE: SHOP DRAWING, DF-2000-24-NA-SF

DES. BY: DRAWN BY: M LEOPOLD DATE: 30 JAN 07

REVISION 00 APPR. BY: SCALE: 1=15 1356-R04B-295722

REV.	DATE	DESCRIPTION	BY	APPR.