



**Galaxy™ Outdoor 34mm  
Louvered LED Displays  
Series AF-3065**

---

**Installation, Maintenance &  
Troubleshooting Manual**

ED-12835

All trademarks are the property of their respective companies.

**ED-12835  
Product #1241  
Rev. 1 – 18 September 2001**

**Copyright© 2001 Daktronics, Inc.**

All rights reserved. While every precaution has been taken in the preparation of this manual, the publisher assumes no responsibility for errors or omissions. No part of this book covered by the copyrights hereon may be reproduced or copied in any form or by any means - graphic, electronic, or mechanical, including photocopying, taping, or information storage and retrieval systems - without written permission of the publisher.



**DAKTRONICS, INC.**

P.O. Box 5128 331 32<sup>nd</sup> Ave. Brookings, SD 57006

Phone (605) 697-4034 or (877) 605-1113 Fax 697-4444

[www.daktronics.com](http://www.daktronics.com) e-mail [helpdesk@daktronics.com](mailto:helpdesk@daktronics.com)



# Table of Contents

---

<b>Section 1:</b>	<b>Introduction .....</b>	<b>1-1</b>
1.1	How to Use This Manual.....	1-1
1.2	Safety Precautions .....	1-2
1.3	Network Concepts .....	1-2
	RS232 Network.....	1-3
	RS422 Network.....	1-3
	Modem Network.....	1-3
	Fiber Optic Network.....	1-3
1.4	Display Overview.....	1-3
RR	1-3	
1.5	Component Identification.....	1-4
1.6	Daktronics Nomenclature.....	1-6
<b>Section 2:</b>	<b>Mechanical Installation .....</b>	<b>2-1</b>
2.1	Mechanical Installation Overview.....	2-1
2.2	Support Structure Design .....	2-1
2.3	Ventilation Requirements.....	2-2
2.4	Lifting the Display.....	2-2
2.5	Display Mounting.....	2-2
2.6	Optional Temperature Sensor Mounting.....	2-3
<b>Section 3:</b>	<b>Electrical Installation .....</b>	<b>3-1</b>
3.1	Common Connectors in the Display.....	3-1
3.2	Control Cable Requirements .....	3-2
	RS232 .....	3-2
	RS422 .....	3-2
	Modem.....	3-2
	Fiber Optic.....	3-2
3.3	RJ Connector Cables .....	3-3
	Installing an RJ Connector.....	3-3
	Pin-Outs .....	3-3
3.4	Conduit.....	3-4
3.5	Preparing for Power/Signal Connection.....	3-4
3.6	Power.....	3-5
	Power Requirements.....	3-5
	Grounding .....	3-5
	Power Installation .....	3-5
	Power Connection.....	3-6
	Main Disconnect.....	3-7
3.7	Signal Termination from Computer to Display.....	3-7
	RS232 .....	3-7
	RS422 .....	3-7
	Modem.....	3-8
	Fiber Optic .....	3-8
3.8	Signal Termination Between Two (or More) Signs .....	3-8

	RS422 Interconnection.....	3-8
	Fiber Interconnection .....	3-9
3.9	Optional Temperature Sensor Electrical Installation.....	3-9
3.10	First Time Turn On.....	3-10
<b>Section 4:</b>	<b>Maintenance &amp; Troubleshooting.....</b>	<b>4-1</b>
4.1	Maintenance & Troubleshooting Overview.....	4-1
4.2	Signal Summary.....	4-1
4.3	Power Summary.....	4-2
4.4	Service & Diagnostics .....	4-2
	Transformer & RFI Filter .....	4-3
	Controller .....	4-3
	Modules & Drivers.....	4-4
	Power Supplies.....	4-5
	Light Detector .....	4-6
	Modem .....	4-6
	Fiber Board.....	4-6
4.5	Ventilation Systems (With Fans and Filters).....	4-7
4.6	Thermostats.....	4-7
4.7	Weather Stripping .....	4-7
4.8	Display Maintenance .....	4-8
4.9	Troubleshooting.....	4-8
4.10	Boot Up Initialization Information .....	4-9
4.11	Replacement Parts List .....	4-9
4.12	Daktronics Exchange/Repair & Return Programs .....	4-10
<b>Appendix A:</b>	<b>Signal Converter .....</b>	<b>A-1</b>
<b>Appendix B:</b>	<b>Reference Drawings .....</b>	<b>B-1</b>

# List of Figures

---

Figure 1: Drawing Label .....	1-1
Figure 2: Controller .....	1-4
Figure 3: Signal Converter (RS232 to RS422 Shown).....	1-5
Figure 4: 8x8 RGB Module (Front and Rear) .....	1-5
Figure 5: Module Numbering Example – 24x80 Front .....	1-6
Figure 6: Module Numbering .....	1-6
Figure 7: Typical Label .....	1-6
Figure 8: Lifting the Display (Correct, Left; Incorrect, Right).....	2-2
Figure 9: Temperature Sensor Eave/Wall Mount.....	2-3
Figure 10: Temperature Sensor Mounting to Bottom of Display.....	2-4
Figure 11: Ribbon Cable Connector .....	3-1
Figure 12: Termination Block .....	3-1
Figure 13: Phoenix Connector.....	3-1
Figure 14: Mate-n-Loc Connector.....	3-2
Figure 15: RJ11 Connector.....	3-2
Figure 16: 6-Conductor RJ-11 Connector and Cable .....	3-3
Figure 17: Flipped Cable with RJ Connectors.....	3-3
Figure 18: Wire with Outer Jacket Stripped.....	3-3
Figure 19: Installation with Ground and Neutral Conductor Provided .....	3-6
Figure 20: Installation with only Neutral Conductor Provided .....	3-6
Figure 21: Controller Component Layout .....	4-3
Figure 22: Removing a Module.....	4-5
Figure 23: Modem .....	4-6
Figure 24: Fiber Optic Board .....	4-6
Figure 25: Signal Converters.....	1



# Section 1: Introduction

---

## 1.1 How to Use This Manual

---

This manual explains the installation, maintenance and troubleshooting of a Daktronics Galaxy 34mm louvered LED (light emitting diode) display (series AF-3065). For questions regarding the safety, installation, operation or service of this system, please refer to the telephone numbers listed on the cover page of this manual.

The manual is divided into six sections: Introduction, Mechanical Installation, Electrical Installation, Maintenance & Troubleshooting, and two Appendices.

- **Introduction** covers the basic information needed to make the most of the rest of this manual. Take time to read the entire introduction as it defines terms and explains concepts used throughout the manual.
- **Mechanical Installation** provides general guidance on display mounting.
- **Electrical Installation** provides general guidance on terminating power and signal cable at the display.
- **Maintenance & Troubleshooting** addresses such things as removing basic display components, troubleshooting the display, performing general maintenance and exchanging display components.
- **Appendix A** provides information on the signal converter.
- **Appendix B** includes the drawings referenced in this manual.

Daktronics identifies manuals by an ED number located on the cover page of each manual. For example, this manual would be referred to as **ED-12835**.

Listed below are a number of drawing types commonly used by Daktronics, along with the information that each is likely to provide. This manual might not contain all these drawings.

- **System Riser Diagrams:** overall system layout from control computer to display, power and phase requirements.
- **Shop Drawings:** fan locations, mounting information, power and signal entrance points and access method (front and rear).
- **Schematics:** power and signal wiring for various components.
- **Component Placement Diagrams:** locations of critical internal display components such as power supply assemblies, controller boards, thermostats and light detectors.

**Figure 1** illustrates Daktronics drawing label. The drawing number is located in the lower-right corner of the drawing. Drawings in the manual are identified by listing the last set of digits and the letter preceding them. In the example below, the drawing would be referred to as **Drawing A-69945**. Reference drawings are inserted in the **Appendix**.

DAKTRONICS, INC. BROOKINGS, SD 57006	
PROJ:	
TITLE:	
DES. BY:	DRAWN BY: DOK
DATE: 04-20-95	
APPR. BY:	7087-P08A-69945
SCALE: 1=80	

**Figure 1:** Drawing Label

All references to drawing numbers, appendices, figures or other manuals are presented in **bold** typeface, as shown below.

“Refer to **Drawing A-69945** in **Appendix B** for the power supply location.”

Additionally, drawings referenced in a particular section are listed at the beginning of that section as seen in the following example:

**Reference Drawings:**

Component Placement Diagram..... **Drawing A-69945**

Daktronics displays are built for long life, and require little maintenance. However, from time to time, certain display components will need replacing. The Replacement Parts List in **Section 4.11** provides the names and part number of components that may need to be ordered during the life of the display. Most display components have a white label that lists the part number. The component part number is in the following format: 0P-XXXX-XXXX (circuit board) or 0A-XXXX-XXXX (multi-component assembly).

Following the Replacement Parts List is the Exchange/Replacement Procedure in **Section 4.12**. Refer to these instructions if any display component needs replacement or repair.

---

## 1.2 Safety Precautions



### Important Safeguards:

1. Read and understand these instructions before installing.
2. Be sure the display is properly grounded.
3. *Disconnect power when servicing the display.*
4. Do not modify the display structure or attach any panels or coverings to the display without the written consent of Daktronics, Inc.

---

## 1.3 Network Concepts

The concept of using LED displays as a cost effective, high impact method of communication is rapidly growing throughout many industries and businesses. The reasons for this growth are many, but the need for additional features and complexity of multiple display installations has emerged, and Daktronics display system have been designed to meet those needs.

The common thread to most client requests is a means of programming and controlling a group of displays from a central control point. Daktronics responded by developing a power system of interconnecting and controlling displays. Great care has been taken to design products that will satisfy a wide variety of installations. Some of the design goals of these systems include the following:

- Easy transfer of messages
- The ability to tell a display or group of displays in the network which message should run
- The ability to determine the status of any display on the network
- The ability to control multiple display technologies on the same network

All that is required for signal installation is standard six (6) conductor modular telephone wire and a tool to install the connector. Tools required for mounting the display depend on the location and size of the display. For some installations, it may be possible to buy pre-terminated telephone cables for use with the displays.



There are four (4) network systems available: RS232, RS422, modem and fiber. Up to 240 displays can exist on one network.

**RS232 Network**

RS232 (EIA/TIA-232-E) is a standard communication interface that employs a single-ended serial transmission scheme that uses a maximum cable length of 8 meters (25 feet). This interface was designed for computer communication at short distances. All computers have an RS232 communications port. Refer to **Section 3** for additional information.

**RS422 Network**

RS422 (EIA/TIA-422-B) is a standard communication interface that utilizes a differential balanced transmission scheme that uses a typical maximum cable length of 1.2 km (approximately 4000 feet). The main advantage to RS422 over RS232 is the longer cable length that is possible. A signal converter is needed to convert the computer's RS232 to RS422. Refer to **Section 3** for additional information.

**Modem Network**

The modem is a standard communication interface that utilizes standard phone transmission lines. The phone company assigns each phone line a number that the modem uses to communicate between controller and display. Refer to **Section 3** for additional information.

**Fiber Optic Network**

A fiber optic network is a standard communication method transmitting light (signal) through a glass fiber. Fiber optic cable has a maximum length of 2,000 feet. A signal converter is needed to convert the computers RS232 signal to fiber optic signal; a minimum of two fibers is required.

---

## 1.4 Display Overview

---

**Reference Drawings:**

Shop Drawing; AF-3065-8-32 High.....	<b>Drawing B-148418</b>
Shop Drawing; AF-3065-40-48 High.....	<b>Drawing B-148419</b>

Daktronics AF-3065 Galaxy displays are designed and manufactured for performance, reliability, easy maintenance and long life. The pixels have a 34mm center-to-center spacing, and are lit using LEDs (light emitting diodes). Each display section has minimum 9-inch character height. A light sensor on the front of the display is used for automatic dimming of the LEDs based on the ambient light levels. The configuration of pixels depends on the model of display ordered.

Refer to the drawings referenced above for the approximate size, weight, and power requirements for your model of display.

The Galaxy model numbers are described as follows: **AF-3065-RRCCC-9-X**

- AF-3065** = Outdoor 34mm Louvered Galaxy Display
- RR** = Number of Rows High (8, 16, 24 and 32 are available)
- CCC** = Number of Columns Long (48, 64, 80, 96, 112, 128, 144 are available)
- 9** = 9" Minimum Character Height
- X** = LED Color (8-color RGB)

A typical display system consists of a Windows® based personal computer (PC) running Venus® 1500 software and one or more displays. The displays are offered as single-face units, which are single-

sided stand-alone displays. They can become double-faced by mounting them back-to-back with a second unit.

The Venus 1500 controller is a software package that runs under Windows 98, ME or NT® 4.0 or 2000 operating systems on an IBM®-compatible computer. Refer to the Venus 1500 controller operator's manual for installation and operation of the Venus 1500 controller editing station.

Refer to **Sections 4.2** and **4.3** for the summaries of how signal and power are routed through the displays.

## 1.5 Component Identification

The following illustrations depict some of the more commonly accessed Galaxy display components. Because Daktronics occasionally alters standard design to meet customer needs, the actual display design may vary slightly from the illustrations below.

**This is only a brief overview. Refer to Section 4 for additional information on maintaining the various display components.**

**Com Port:** A COM port is a connector on the back of the control computer. The COM port is used to control the display network through either a 9- or a 25-pin serial connector.

**Controller:** The display's controller is the "brains" of the display (refer to **Figure 2**). The controller receives signal information from the control computer, translates it, and activates the appropriate pixels on the display accordingly.

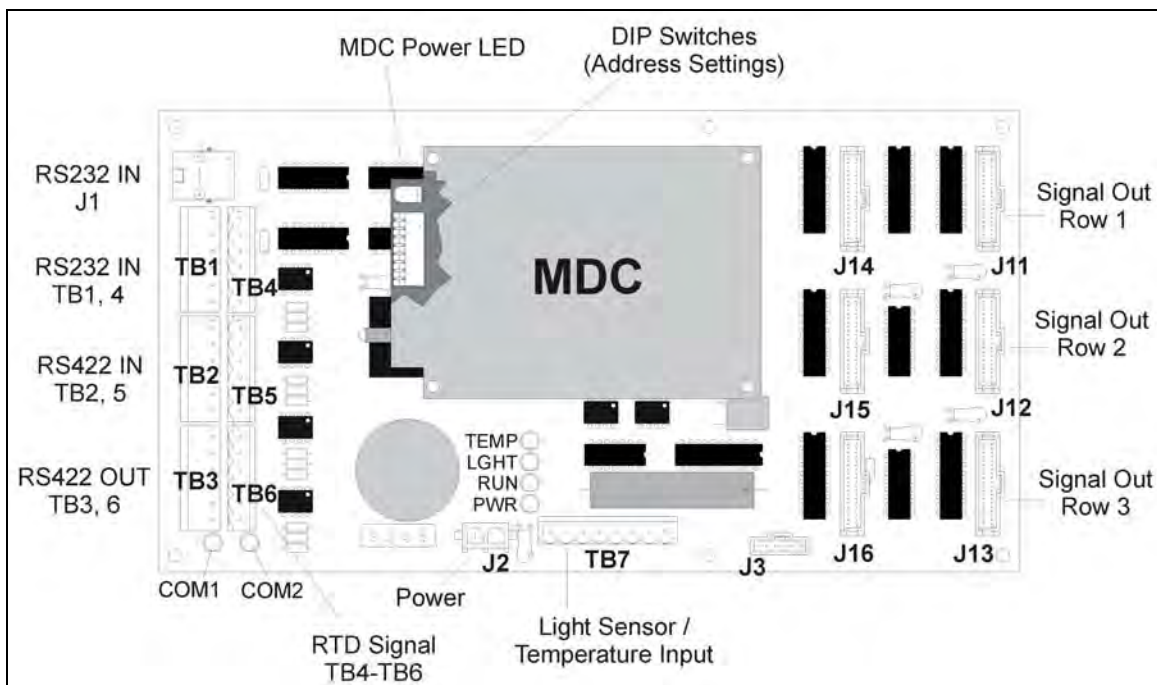

**Figure 2:** Controller

**Galaxy™:** Daktronics trademarked name for LED monochrome, tri-colored or RGB matrix displays.

**Network:** A network consists of multiple displays connected to each other. Up to 240 displays can exist on one network.

**Power Supply:** converts AC line voltage from the load center to low DC voltage for one or more module driver boards.

**RS232:** RS232 is a standard PC communication type with a maximum cable length of 25 feet (7.62 meters).

**RS422:** RS422 is a standard differential communication type with a maximum cable length of 4000 feet (1.2 kilometers).

**Display Address:** The display address is an identification number assigned to each display of a network. It is set by flipping DIP switches on the controller. The control software uses the address to locate and communicate with each display. Displays that are on the same network cannot have the same address.

**Signal Converter:** The signal converter, shown in **Figure 3**, is a Daktronics supplied unit that converts the data from RS232 to RS422, or RS232 to fiber optic signal. The signal converter is connected to the control PC via straight through serial cable.

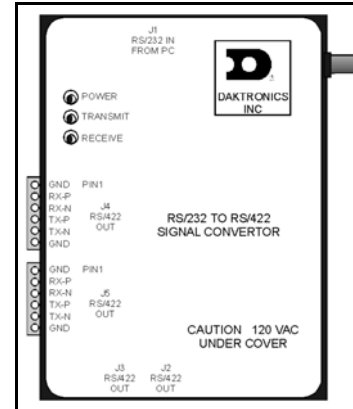

**Figure 3:** Signal Converter (RS232 to RS422 Shown)

Refer to **Figure 3** and **Figure 4** while reading the following component descriptions.

**Driver/Pixel Board:** The LED pixels are mounted directly onto the driver/pixel board. This board is also responsible for the switching and intensity levels of the LEDs.

**LED (light emitting diode):** low energy, high intensity lighting units.

**Louver:** a black plastic shade positioned horizontally above each pixel row. The louvers increase the level of contrast on the display face and direct LED light.

**Module:** 34mm Galaxy modules are 8 pixels high by 8 pixels wide. Each is individually removable from the front of the display.

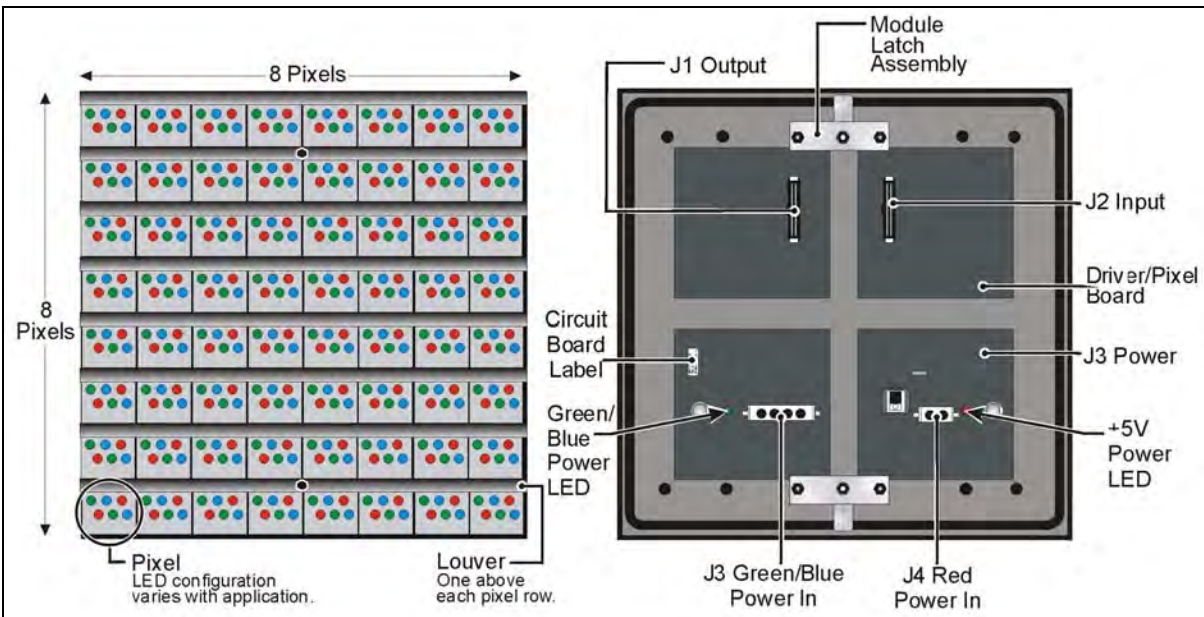

**Figure 4:** 8x8 RGB Module (Front and Rear)

**Module Latch Assembly:** device utilizing a rotating retainer bar to hold the module firmly to the display frame. There are two per module: one near the top and one near the bottom. Use a 1/8" Allen wrench to turn the retaining bar.

**Pixel:** a cluster of LEDs. The number and color of the LEDs depends on display application.

## 1.6 Daktronics Nomenclature

To fully understand some Daktronics drawings, such as schematics, it is necessary to know how various components are labeled in those drawings. This information is also useful when trying to communicate maintenance or troubleshooting efforts.

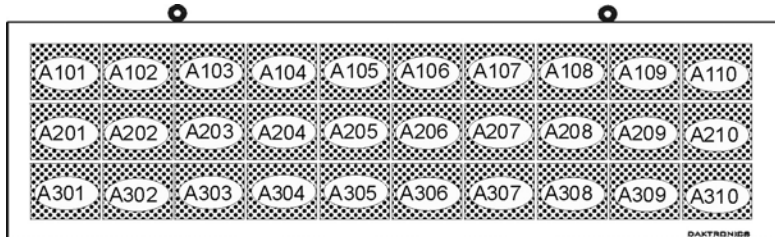

**Figure 5:** Module Numbering Example – 24x80 Front

A module is the building block of the Galaxy display. Each module measures 8 pixels high by 8 pixels wide. By placing modules side-by-side and on top of one another a display of any size can be designed and built. Individual modules can be easily removed from the display if required. **Figure 5** illustrates how Daktronics numbers modules on a Galaxy display. **Figure 6** breaks down the module numbering method.

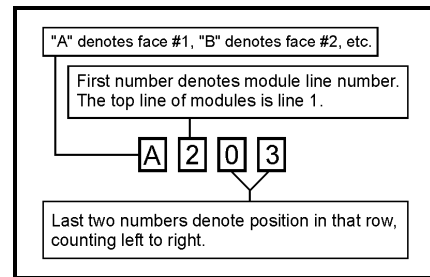

**Figure 6:** Module Numbering

The label “A” on a drawing typically denotes an assembly. An assembly can be a single circuit board or a collection of components that function together, usually mounted on a single plate or in a single enclosure. Assemblies are divided into two types: those that route signal and those that route power.

In addition, the following labeling formats might be found on various Daktronics drawings:

- “TB??” denotes a termination block for power or signal cable.
- “F??” denotes a fuse.
- “E??” denotes a grounding point.
- “J??” denotes a power or signal jack.
- “P??” denotes a power or signal plug for the opposite jack.

Finally, Daktronics part numbers are commonly found on drawings. Those part numbers can be used when requesting replacement parts from Daktronics Customer Service. Take note of the following part number formats.

- “OP-????-????” denotes an individual circuit board, such as a line receiver.
- “OA-????-????” denotes an assembly, such as a circuit board and the plate or bracket to which it is mounted. A collection of circuit boards working as a single unit may also carry an assembly label.
- “W-????” denotes a wire or cable. Cables may also carry the assembly numbering format in certain circumstances. This is especially true of ribbon cables.

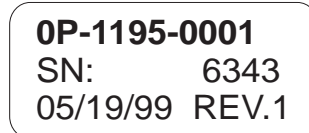

**Figure 7:** Typical Label

Most circuit boards and components within this display carry a label that lists the part number of the unit. If a circuit board or assembly is not listed in the replacement parts list in **Section 4**, use the label to order a replacement. A typical label is shown in **Figure 7**. The part number is in bold.

# Section 2: Mechanical Installation

---

🔔 **Notes:** *Daktronics does not guarantee the warranty in situations where the display is not constantly in a stable environment.*

Daktronics engineering staff must approve *any* changes that may affect the weather-tightness of the display. If any modifications are made, detailed drawings of the changes *must* be submitted to Daktronics for evaluation and approval, or the warranty may be void.

*Daktronics is not responsible for installations or the structural integrity of support structures done by others.* It is the customer's responsibility to ensure the structure and any additional hardware have been approved by a qualified structural engineer.

## 2.1 Mechanical Installation Overview

---

Because every installation site is unique, there is no single Daktronics-approved procedure for mounting the Galaxy displays. The information contained in this section is general information only and may or may not be appropriate for your particular installation.

**A qualified individual must make all decisions regarding the mounting of this display.**

**Read both the mechanical and electrical installation sections of this manual before beginning any installation procedures.**

## 2.2 Support Structure Design

---

Support structure design depends on the mounting methods, display size and weight. The structure design is critical and should be done only by a qualified individual. Display height and wind loading are also critical factors. It is the customer's responsibility to ensure that the structure and mounting hardware are adequate. *Daktronics is not responsible for the installations or the structural integrity of support structures done by others.*

**It is the installer's responsibility to ensure the mounting structure and hardware are capable of supporting the display, and will agree with local codes.**

Before beginning the installation process, verify the following.

- The mounting structure will provide a straight and square mounting frame for the display.
- The mounting structure is capable of supporting the display and will not yield at any unsupported points after mounting.
- Clearance: 3" of unobstructed space is available below the display for filter removal from the display. 1-1/4" of unobstructed space is available above the top of the display.

Correct any deficiencies before installation.

## 2.3 Ventilation Requirements

---

### Reference Drawings:

Shop Drawing; AF-3065-8-32 High.....	<b>Drawing B-148418</b>
Shop Drawing; AF-3065-40-48 High.....	<b>Drawing B-148419</b>

Fans are mounted in the bottom of the display and to the back sheet for ventilation. Maintain a minimum distance of 3" (7.62cm) below the display to maintain proper airflow. Refer to the appropriate shop drawing for additional information.

*If the display cabinet is completely enclosed:*

- 6 square inches of unobstructed opening per module must be provided to ensure adequate cooling.
- Allowances must be made to compensate for the percentage of material covering the openings in the structure.
- For adequate cooling, forced ventilation may be required. If air is forced into the enclosed cabinet, 10 cubic feet per minute must be provided per module (10.6" x 10.6" active area).

If these requirements are not met, the Galaxy display warranty may be void.

## 2.4 Lifting the Display

---

The top of the larger displays is equipped with eyebolts that are used to lift the unit. Take special care to ensure that the rated load of the eyebolts is not exceeded. Refer to the information at the end of this section labeled **Eyebolts** to determine the allowable load of the eyebolts shipped with the display.

**Figure 8** illustrates both the correct (left example) and the incorrect (right example) method of lifting a display. Lift the display as shown on the left, *with the lifting bar*. Use every lifting point provided!

*Do not attempt to permanently support the display by the eyebolts.*

**If removing the eyebolts, adequately seal the holes using 1/2-13 bolts and sealing washers and silicone along the threads. This ensures that water does not enter the display.**

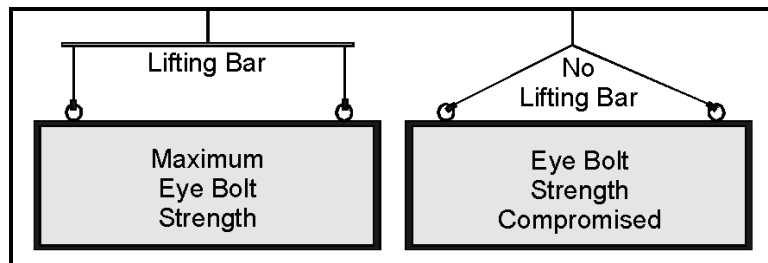

**Figure 8:** Lifting the Display (Correct, Left; Incorrect, Right)

## 2.5 Display Mounting

---

### Reference Drawings:

Mtg Clip Angles; AX-XXXX-40/48XX-34B.....	<b>Drawing A-128799</b>
Mtg Clip Angles AX-XXX-8/32XX-34B.....	<b>Drawing A-128801</b>
Shop Drawing; AF-3065-8-32 High.....	<b>Drawing B-148418</b>
Shop Drawing; AF-3065-40-48 High.....	<b>Drawing B-148419</b>

The method used to mount displays can vary greatly from location to location. For this reason, only general mounting topics can be addressed in this manual.

**It is the responsibility of the installer to ensure the installation will adequately meet local codes and standards. The mounting hardware and method is also the responsibility of the installer.**

Before beginning the installation process, verify the following items.

- The mounting structure will provide a straight and square mounting frame for the display. *Height variation in any four-foot horizontal section may not exceed 1/4-inch.*
- The mounting structure will not give way at any unsupported points after the display is mounted.

The back of the display is equipped with 2 x 2 x 1/4" steel clip angles at the locations shown in **Drawings A-128799** and **A-128801**. These angles may be used for mounting purposes. Remember to have *all* mounted displays inspected by a qualified structural engineer. It is the customer's responsibility to determine the proper wall mounting method and location.

Refer to **Drawing A-128799** for a suggested wall mount method. The number of attachment points needed and the wall structure *must* be reviewed by a qualified structural engineer and meet all national and local codes. *Daktronics recommends using all clip angles as attachment points.*

1. Carefully uncrate the display. Look each side of the display over for damage during shipping.
2. Following the guidelines described in **Section 2.4**, lift the display into position on the support structure.
3. Weld or use 1/2" Grade-5 bolts and hardware to secure the clip angles to the support structure as shown in **Detail A** in **Drawing A-128799**.
4. Refer to **Section 3** for information on routing power and signal.
5. After installation is complete, carefully inspect the display for any holes that may allow water to seep into the display. Seal any openings with silicone. If the eyebolts on the top of the display have been removed, plug the holes with bolts and the rubber sealing washer that was removed with the eyebolt.

## 2.6 Optional Temperature Sensor Mounting

The optional temperature sensor is mounted separately and requires a location away from the influence of chimneys, air conditioners, vents, tar roofs, concrete and parking lots which can cause abnormal temperature fluctuations. Usually a separation of at least 20 to 30 feet horizontally and eight feet vertically is required to achieve this. Locations where air movement is restricted are also unsatisfactory.

A first-choice temperature sensor location is a north eave or northern exposure away from direct sun light and above grass. This location gives extra stability and accuracy to the sensor because of the added shading usually obtained on a northern exposure. There should be at least one foot between the bottom of the eave and the top of the temperature sensor housing for accurate readings, as seen in **Figure 9**.

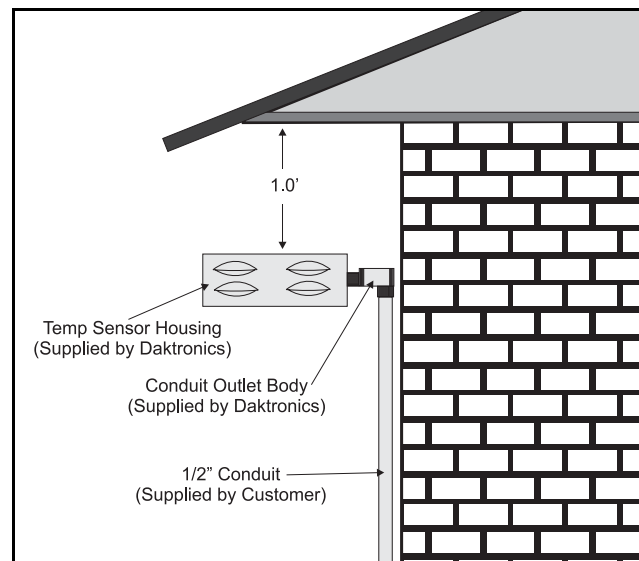
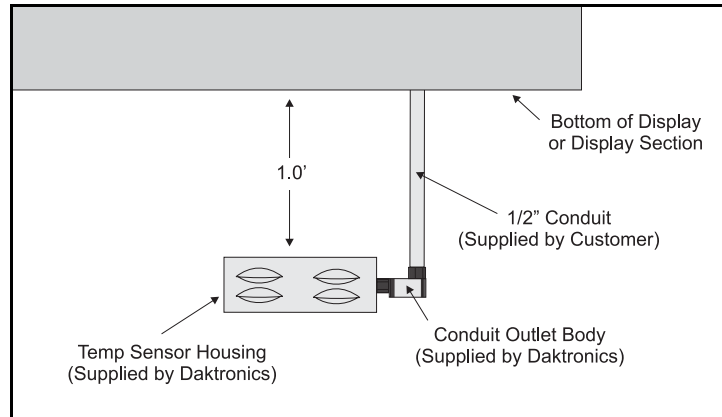

**Figure 9:** Temperature Sensor Eave/Wall Mount

*Due to the nature of the signal cable used to send the temperature information, the maximum distance between the temperature sensor and the display is 1,000 feet (304.8 meters).*

The second choice for locating a temperature sensor is on the display itself, or somewhere on the display structure. A light-colored display is preferred in this application. Location of the sensor should be above, below, or on a northern edge to try to keep the sensor shaded. If mounting above the display, a minimum height above of six feet is required. If mounting below the display, a minimum of eight feet above ground and a minimum of one foot between sensor and display are required, as seen in **Figure 10**. Greater accuracy is obtained if there is grass below the display rather than concrete or some other material.

Refer to **Section 3.9, Optional Temperature Sensor Electrical Installation** for wiring instructions.



**Figure 10:** Temperature Sensor Mounting to Bottom of Display



# Section 3: Electrical Installation

*Only a qualified individual should terminate power and signal cable within this Daktronics display!*

The Daktronics engineering staff must approve ANY changes made to the display. Before altering the display, submit detailed drawings for the proposed modifications to the Daktronics engineering staff for evaluation and approval or the warranty will be rendered null and void.

## 3.1 Common Connectors in the Display

The power and signal connections in the displays use many different types of connectors. Take special care when disengaging any connector so as not to damage the connector, the cable or the circuit board.

**When pulling a connector plug from a jack, do not pull on the wire or cable; pull on the jack itself. Pulling on the wires may damage the connector.**

The following information presents some common connectors encountered during display installation and maintenance.

### 1. Ribbon Cable Connectors:

**Figure 11** illustrates a typical ribbon connector. To disconnect the ribbon cable, push the metal clips on the sides to unlock and remove the jack.

Before replacing a ribbon cable connector, spray it with Deoxit™ contact cleaner to remove any foreign matter that may cause signal problems. In addition, apply a generous amount of Cal-Lube™ protector paste to the plug before inserting it into the jack. This paste will protect both the plug and the jack from corrosion.

### 2. Termination Blocks:

Termination blocks are usually used to connect internal power and signal wires to wires of the same type coming into the display from an external source. Power wires need to have one-half inch of insulation stripped from the end of the wire prior to termination. Tighten all screws firmly to ensure a good electrical connection. Refer to **Figure 12**.

### 3. Phoenix™-Style Connectors:

Phoenix-style connectors, which are usually green, are often used for signal termination on circuit boards. Refer to **Figure 13**. Strip one-quarter inch of insulation from the wire prior to termination. To remove a wire, turn the above screw counter-clockwise to loose the connectors grip on the wire. To insert a wire, push the bare wire into the connector and turn the above screw clockwise to lock the wire into place.

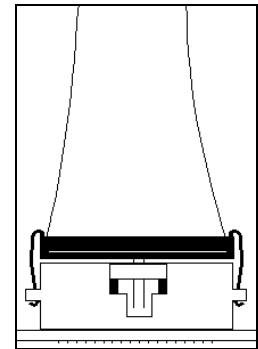

**Figure 11:** Ribbon Cable Connector

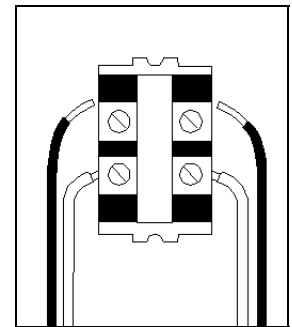

**Figure 12:** Termination Block

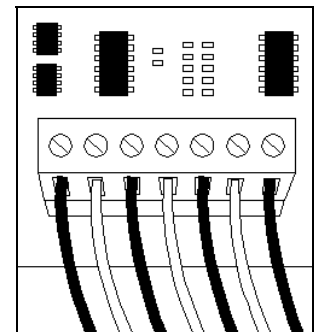

**Figure 13:** Phoenix Connector

#### 4. Mate-n-Lok™ Connectors:

The Mate-n-Lok connectors found in the displays are white and come in a variety of sizes. **Figure 14** illustrates a four-pin Mate-n-Lok connector. To remove the plug from the jack, squeeze the plastic locking clasps on the side of the plug and pull it from the jack.

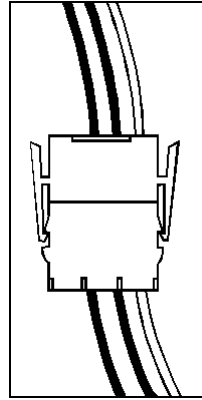

**Figure 14:** Mate-n-Loc Connector

#### 5. Phone Jacks (RJ11 Connectors):

RJ connectors, as seen in **Figure 15**, are similar to the telephone connectors found in homes and are used on the ends of flat RJ11 cable. In order to remove this plug from the jack, depress the small clip on the underside of the plug.

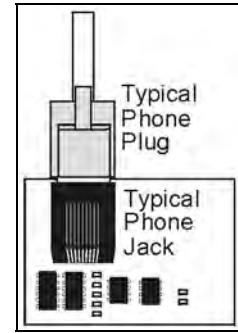

**Figure 15:** RJ11 Connector

Before replacing an RJ connector, spray it with Deoxit™ contact cleaner to remove any foreign matter that may cause signal problems. In addition, apply a generous amount of Cal-Lube protector paste to the plug before inserting it into the jack. This paste will protect both the plug and the jack from corrosion.

### 3.2 Control Cable Requirements

---

#### **RS232**

This cable is a 2-conductor shielded cable used to transmit an RS232 signal (Daktronics part number W-1117). This shielded cable should not be subjected to mechanical flexing after installation. This cable is not for direct burial and should be routed in a dedicated, grounded metallic conduit at the base of the sign structure. This cable has a maximum length of 25 feet.

#### **RS422**

This cable is a 6-conductor shielded cable used to transmit an RS422 signal (Daktronics part number W-1210). This shielded cable consists of unpaired wires. They should not be subjected to mechanical flexing after installation. This cable is not for direct burial and should have one of the following routings:

- In dedicated metallic conduit
- Inside buildings – if cable is not in conduit, keep away from interference signals.

☞ With interference signals (such as power conductors, intercom, etc.) typically a two foot separation is required. The maximum length of an RS422 signal cable is 4,000 feet (1.22 km).

#### **Modem**

The modem option will use standard telephone cable routed through conduit. The local telephone company will need to assist in this installation.

Ask the telephone company which colors are used by the TIP, and the RING for signal hook up.

**Note:** The telephone lines must be dedicated lines and *not* run through a switch board/communications system.

#### **Fiber Optic**

This cable is a 4-fiber cable (Daktronics part number W-1376). Two fibers are used for display communications and the other two are saved for spares. The cable may be either direct burial or routed in conduit but it should not be subjected to mechanical flexing. The maximum length of a fiber optic cable is 2,000 feet (611.6 meters).

### 3.3 RJ Connector Cables

The conductor connector used in the network is an industry standard, 6-pin RJ11. This connector can be found on many telephones and LANs.

The cable used in the network is a standard flat six conductor telephone cable (**standard flipped cable**). Refer to **Figure 16**. This cable has one end that is the mirror image of the other end (i.e. the cable is flipped). Refer to **Figure 17** for a standard flipped cable.

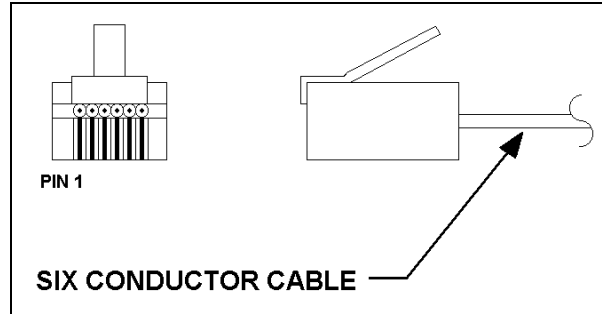

**Figure 16:** 6-Conductor RJ-11 Connector and Cable

Notice in **Figure 17** that the color code on one connector must be made the opposite on the other connector. When installing a network, it is not easy to remember in which direction the previous end was oriented. One simple way to avoid confusion is to standardize the color code, having one color for the connector going into the output of a sign and the opposite color for a connector going into the input of a sign. This will help ensure correct cabling since cables are always installed from the output jack of one sign to the input jack of the next sign.

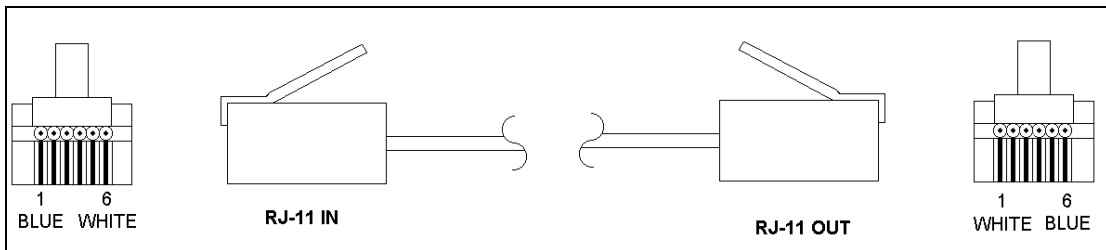
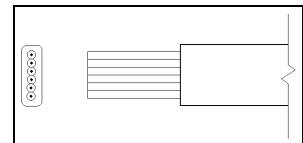

**Figure 17:** Flipped Cable with RJ Connectors

#### ***Installing an RJ Connector***

Installing an RJ connector on the end of the conductor cable is a simple task when the correct tools are used. The RJ crimping tool (Daktronics part number TH-1033) performs two separate steps.

First, use the crimping tool to strip the outer insulation from the inner wires. This does not result in bare wires since only the gray outer jacket is removed. After correct stripping, the wire will appear as shown in **Figure 18**.



**Figure 18:** Wire with Outer Jacket Stripped

The crimping tool is then used to crimp the RJ connector onto the cable. The RJ connector is locked into a special socket in the tool. The stripped wire is inserted into the RJ connector. Finally, the tool is squeezed like a pliers to crimp the connector onto the wire. This completes the installation of an RJ connector onto the wire.

#### ***Pin-Outs***

The RS422 jack's pin out is as follows:

RJ11	Function	RJ11	Function
1	GROUND	4	D1IN-P
2	D1OUT-P	5	D1IN-N
3	D1OUT-N	6	GROUND

### 3.4 Conduit

---

#### Reference Drawings:

System Riser Diagram, RS232.....	Drawing A-96058
System Riser Diagram, RS422.....	Drawing A-92681
System Riser Diagram, Modem.....	Drawing A-88426
System Riser Diagram, Fiber .....	Drawing A-110559
Signal Input, Venus 1500 .....	Drawing A-129110
Entrance Box 8/16.....	Drawing A-149160
Assy, Power Box 2/4 .....	Drawing A-155736
Shop Drawing; AF-3065-8-32 High.....	Drawing B-148418
Shop Drawing; AF-3065-40-48 High.....	Drawing B-148419

*Daktronics does not include the conduit. Refer to Drawings B-148418 and B-148419 for approximate locations for power and signal conduit. Separate conduit must be used to route:*

- Power
- Signal IN wires
- Signal OUT wires (if signal is required for another display)

Knockout holes for ½" conduit are located at the bottom right (rear view) of the back of the display (refer to **Drawings B-148418** and **B-148419**).

☞ For displays with more than one face, signal and temperature sensor wiring between displays can be routed through the same conduit.

### 3.5 Preparing for Power/Signal Connection

---

#### Reference Drawings:

System Riser Diagram, RS232.....	Drawing A-96058
System Riser Diagram, RS422.....	Drawing A-92681
System Riser Diagram, Modem.....	Drawing A-88426
System Riser Diagram, Fiber .....	Drawing A-110559
Signal Input, Venus 1500 .....	Drawing A-129110
Entrance Box 8/16.....	Drawing A-149160
Power Connection, AF-306X.....	Drawing A-154965
Assy, Power Box 2/4 .....	Drawing A-155736
Shop Drawing; AF-3065-8-32 High.....	Drawing B-148418
Shop Drawing; AF-3065-40-48 High.....	Drawing B-148419
Detail drawing, Controller and Power Term 24-48 High.....	Drawing B-156686
Component Layout Diagram.....	Appendix B
Schematic .....	Appendix B

1. Punch or use 7/8" (0.875) conduit holes for the desired conduit openings. *Be careful that none of the internal components are damaged.* Refer to **Drawings B-148418** and **B-148419**. Attach the conduit.
2. Remove the bottom left two modules (AX01 and AX02) to expose the power enclosure and signal panel. To do this, use a nut driver or 1/8" Allen wrench to turn the latch access fasteners one-quarter turn. Turn the top latch clockwise and the bottom latch counter-clockwise. Lift each module away from the display; reach behind it and disconnect all power and signal connections.
3. Locate the controller and power termination box for these displays in the **Component Layout Diagram**. The controller is shown in **Figure 2**. The controller receives the incoming signal and relays it to the individual modules.

4. Route power to the display through a fused disconnect switch capable of opening all ungrounded power conductors. Install this disconnect within the line of sight of any personnel performing maintenance on the display. *If the disconnect is located out of sight of the display, it must be capable of being locked in the open position.*
5. Power conductors from the disconnect to the display should be routed through conduit in agreement with local code.
6. You may route the signal cable from the control computer to the display at this time also. *Be sure to run the power and signal cables in a separate conduit.*

### 3.6 Power

---

#### Reference Drawings:

Power Specs, 8x144 Display RGB .....	<b>Drawing A-148571</b>
Entrance Box 8/16.....	<b>Drawing A-149160</b>
Assy, Power Box 2/4 .....	<b>Drawing A-155736</b>
Power Connection, AF-306X .....	<b>Drawing A-154965</b>
Schematic .....	<b>Appendix B</b>

#### **Power Requirements**

Refer to **Drawing A-148571** for voltage and current requirements for your display size. Each uses a 120VAC or 120/240 VAC single-phase power source. Depending on the module color and display size the power supply may vary.

*Do not connect the displays to any voltage other than that listed on the Daktronics product label.*

Proper power installation is imperative for proper display operation. The following sub-sections give details of display power installation.

#### **Grounding**

 *Displays **MUST** be grounded according to the provisions outlined in Article 250 of the National Electrical Code®. Daktronics recommends a resistance to ground of 10 ohms or less.*

The display system *must* be connected to earth-ground. Proper grounding is necessary for reliable equipment operation. It also protects the equipment from damaging electrical disturbances and lightning. **The display must be properly grounded or the warranty will be void.**

The material of an earth-ground electrode differs from region to region and from conditions present at the site. Consult the National Electrical Code and any local electrical codes that may apply. The support structure of the display cannot be used as an earth-ground electrode. The support is generally embedded in concrete, and if in earth, the steel is either primed or it corrodes, making it a poor ground.

#### **Power Installation**

There are two considerations for power installation; installation with ground and neutral conductors provided and installation with only a neutral conductor provided. These two power installations differ slightly, as described in the following paragraphs:

##### **Installation with Ground and Neutral Conductors Provided**

For this type of installation, the power cable *must* contain an isolated earth-ground conductor. Under this circumstance, *do not* connect neutral to ground at the disconnect or at the display. This would violate electrical codes and void the warranty. Use a disconnect so that all hot

lines and neutral can be disconnected. Refer to **Figure 19** for installation details. The National Electrical Code requires the use of a lockable power disconnect within sight of or at the sign.

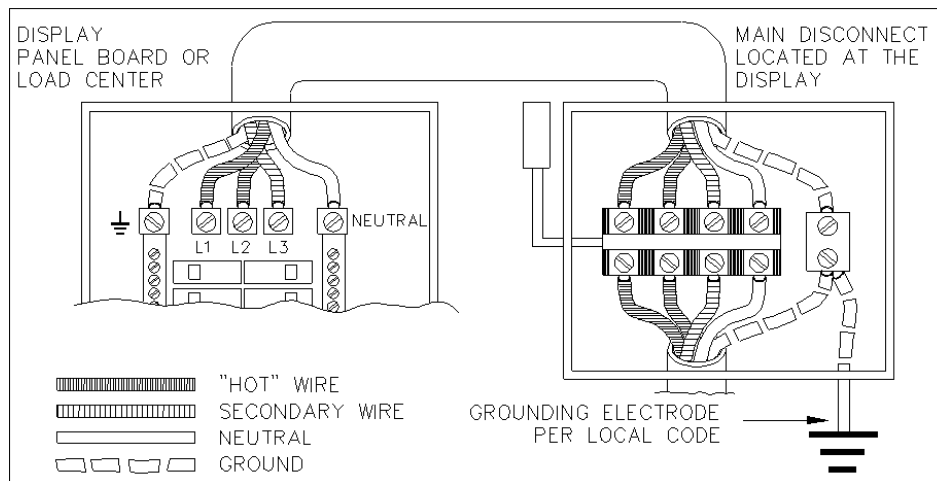

**Figure 19:** Installation with Ground and Neutral Conductor Provided

### Installation with Only a Neutral Conductor Provided

Installations where no grounding conductor is provided must comply with article 250-32 of the National Electrical Code. If the installation in question meets all of the requirements of article 250-32, the following guidelines must be observed:

- Connect the grounding electrode cable at the local disconnect, never at the sign panelboard.
- A disconnect that opens all of the ungrounded phase conductors should be used.
- The neutral and the ground conductors should be bonded in the sign panelboard.

Refer to **Figure 20** for installation details.

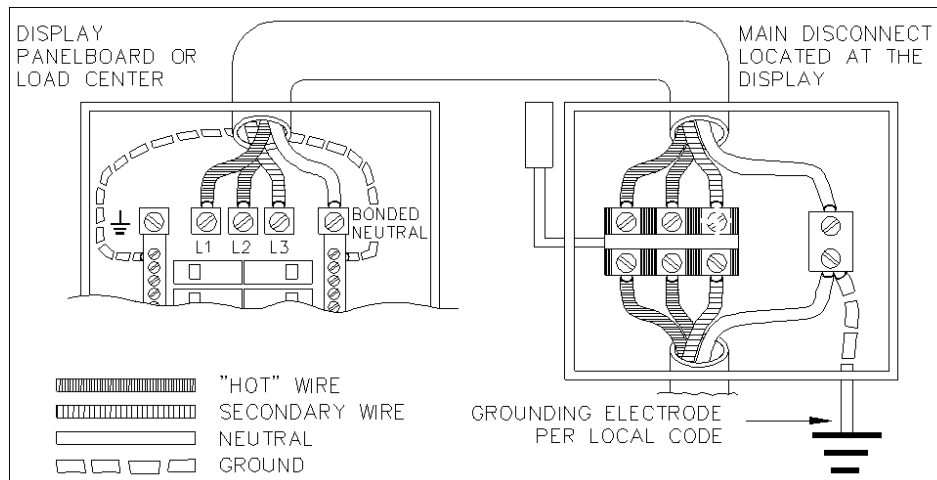

**Figure 20:** Installation with only Neutral Conductor Provided

### Power Connection

Incoming power is connected within the power termination enclosure. Complete the following steps to terminate the hot and neutral wires at the termination block within the enclosure. Refer to **Drawing A-149554** and the appropriate schematic for your display size.

1. Access the enclosure by removing the left bottom two modules as described in **Section 3.5**.

2. Route the power cables through the power conduit in the rear of the sign and to the enclosure.
3. Connect the white neutral wire to neutral bus.
4. *If one power line is being terminated* (120VAC), connect the black “hot” wire to L1. Install jumper per **Drawing A-154965**.
5. *If two power lines are being terminated* (120/240VAC). Connect the second “hot” wire to L2.
6. Connect the green grounding wire to the grounding bus L1. Refer to **Figure 19**.

### **Main Disconnect**

The National Electrical Code requires the use of a lockable power disconnect near the display. Provide a lockable disconnect switch (knife switch) at the display location so that all power lines can be completely disconnected. Use a 3-conductor disconnect so that both hot lines and the neutral can all be disconnected. The main disconnect should be mounted at or near the point of power supply connection to the display. A main disconnect is to be provided for each supply circuit to the display.

The disconnecting means must be located in a direct line of sight from the display or outline lighting that it controls. This requirement provides protection by enabling a worker to keep the disconnecting means within view while working on the display.

**Exception:** Disconnecting means that are *capable of being locked* in the open position may be located elsewhere.

## **3.7 Signal Termination from Computer to Display**

---

### **Reference Drawings:**

System Riser Diagram, Modem.....	<b>Drawing A-88426</b>
System Riser Diagram, RS422.....	<b>Drawing A-92681</b>
System Riser Diagram, RS232.....	<b>Drawing A-96058</b>
System Riser Diagram Fiber.....	<b>Drawing A-110559</b>
Schematic; Fiber/Modem Input.....	<b>Drawing A-125900</b>
Signal Input, Venus 1500 .....	<b>Drawing A-129110</b>

### **RS232**

One end of the signal cable should terminate to the 6-position terminal block on the controller labeled “RS232 IN” (TB1). **Drawing A-129110** shows the terminal block wiring. The opposite end terminates at the J-box near the display. The controlling computer connects to the J-box through the serial cable (refer to **Drawing A-96058**).

<b>J-Box</b>	<b>Field Cabling</b>	<b>Terminal Block TB1 (RS232 In)</b>
		Pin 1 (RTS)
		Pin 2 (GND)
Pin 2 (RX-P)	Clear	Pin 3 (TX-P)
Pin 3 (GND)	Shield	Pin 4 (GND)
Pin 1 (TX-P)	Black	Pin 5 (RX-P)
		Pin 6 (DCD)

### **RS422**

One end of the signal cable should terminate to the 6-position terminal block in the display labeled “RS422 IN” (TB2). **Drawing A-129110** shows the terminal block wiring. The opposite end is terminated at the signal converter (Daktronics part number 0A-1127-0237) in the control room.

Signal Converter (J4/J5)	Field Cabling	Terminal Block TB2 (RS422 In)
Pin 1 (GND)	Red	Pin 1 (GND)
Pin 2 (RX-P)	Black	Pin 2 (TX-P)
Pin 3 (RX-N)	Brown	Pin 3 (TX-N)
Pin 4 (TX-P)	White	Pin 4 (RX-P)
Pin 5 (TX-N)	Blue	Pin 5 (RX-N)
Pin 6 (GND)	Green	Pin 6 (GND)
	Bare (Shield)	N.C.

### Modem

In a display that uses a modem, **Signal In** routes first to a telecommunications connector and terminated per the table below. A 6-conductor phone cord with RJ11 connectors (part number 0A-1137-0160) relays the signal to the modem (refer to **Drawing A-125900**). A second phone cord (0A-1137-0160) transfers the data from the modem to J1 (RS232 IN) on the controller.

Terminal Block TB31	Function
Pin 1	
Pin 2	
Pin 3	TIP-P
Pin 4	Ring-P
Pin 5	
Pin 6	

### Fiber Optic

When fiber optic cables are used, signal from the converter enters the fiber board (J4/J5). An adapter module (Daktronics part number 0A-1146-0029) allows the use of a 6-conductor phone cord with RJ11 connectors (part number 0A-1137-0160) to relay the signal to J1 (RS232 IN) on the controller.

Signal Converter	Field Cabling	Sign A Data In
J2 (TX1)		J5 (RX2)
J3 (RX1)		J4 (TX2)

## 3.8 Signal Termination Between Two (or More) Signs

---

### Reference Drawings:

System Riser Diagram, RS232.....	<b>Drawing A-96058</b>
System Riser Diagram, RS422.....	<b>Drawing A-92681</b>
System Riser Diagram, Modem.....	<b>Drawing A-88426</b>
System Riser Diagram, Fiber .....	<b>Drawing A-110559</b>
Schematic; Fiber/Modem Input.....	<b>Drawing A-125900</b>
Signal Input, Venus 1500 .....	<b>Drawing A-129110</b>

### RS422 Interconnection

This is the most common method of terminating signal between two or more displays. A 6-conductor cable is used and one end terminates at the “RS422 OUT” 6-position terminal block (TB3) on the first display. The other end terminates at the “RS422 IN” 6-position terminal block (TB2) in the second display.



Display A Data Out (TB3)	Field Cabling	Display B Data In (TB2)
Pin 1 (GND)	Green	Pin 6 (GND)
Pin 2 (Data TX-N)	Blue	Pin 5 (Data RX-N)
Pin 3 (Data TX-P)	White	Pin 4 (Data RX-P)
Pin 4 (Data RX-N)	Brown	Pin 3 (Data TX-N)
Pin 5 (Data RX-P)	Black	Pin 2 (Data TX-P)
Pin 6 (GND)	Red	Pin 1 (GND)
Pin 6 (GND)	Bare (Shield)	N.C.

### **Fiber Interconnection**

A four-conductor fiber cable is used in connecting two or more displays in the Fiber Interconnection method. Connect the fiber cable to the fiber cards of the display as described in **Drawing A-125900** and on the following table.

Display A Data Out (J2 & J3)	Field Cabling	Display B Data In (J4 & J5)
J2 (TX1)		J5 (RX2)
J3 (RX1)		J4 (TX2)

## **3.9 Optional Temperature Sensor Electrical Installation**

### **Reference Drawings:**

Temp Sensor Mounting ..... **Drawing A-79767**  
Signal Input, Venus 1500 ..... **Drawing A-129110**

After mounting the optional temp sensor as described in **Section 2.6, Optional Temperature Sensor Mounting**, follow these steps to complete the electrical installation. A 2-pair, individually shielded cable (Belden 5594, Daktronics part number W-1234) is used to connect the sensor to the controller.

1. Run ½" conduit from the sensor location to the controller within the display. The cable must be routed through one-foot of ½" metal conduit that should be earth-grounded to protect the sensor and controller from lightning damage.
2. Connect the cable to the temperature sensor terminal block *within the temperature sensor as follows*:

Wire Color	Terminal Block
Red	V+
Green	P
Black	GND
White	N

**\*Note:** Do not terminate shield at this point.

3. Install the mesh screen with the four screws enclosed.
4. Disconnect power to the display before attaching the cable.
5. Connect the cable to the temperature sensor terminal block on the controller (TB7) per the following table:

Wire Color	Terminal Block TB7 (Temp In)
	Pin 1 (+5V)
	Pin 2 (GND)
	Pin 3 (LIGHT +)
	Pin 4 (LIGHT -)
Green	Pin 5 (TEMP +)
White	Pin 6 (TEMP -)
Red	Pin 7 (+5V)
Black & Shield	Pin 8 (GND)
<b>OR</b> Bare (Shield)	Pin 8 (GND)

To connect the temperature sensor to multiple displays (such as a double-face display):

Wire Color	Display 1 TB7	Display 2 TB7
<b>Green</b>	Pin 5 (TEMP +)	Pin 5 (TEMP +)
<b>White</b>	Pin 6 (TEMP -)	Pin 6 (TEMP -)

### 3.10 First Time Turn On

---

When first powered up, the display will run through an initialization in which it will display the following:

1. Output Test (DDD)
2. Product Name (Galaxy)
3. Display Size (Row x Column)
4. Firmware Number (**ED-12699**)
5. Firmware Revision (Rev X.XX)
6. COM1 Configuration (C1: V15/RTD)
7. COM2 Configuration (C2: None)
8. Line Frequency (60 Hz)
9. Hardware Address (HW: XX)
10. Software Address (SW: XX)
11. Display Name
12. Modem (If modem is present)

# Section 4: Maintenance & Troubleshooting

---



## IMPORTANT NOTES:

1. **Power must be turned off before any repair or maintenance work is done on the display!**
2. **Any access to internal display electronics must be made by qualified service personnel.**
3. **The Daktronics engineering staff must approve ANY changes made to the display.** Before altering the display, detailed drawings for the proposed modifications must be submitted to the Daktronics engineering staff for evaluation and approval or the warranty will be rendered null and void.

## 4.1 Maintenance & Troubleshooting Overview

---

Daktronics Galaxy series AF-3065 displays are front accessible; meaning access to the internal components can be gained only from the front of the display.

This section provides the following Galaxy display information.

- **Signal Routing Summaries:** provide a basic explanation of the signal travel through the display.
- **Power Routing Summaries:** provide a basic explanation of the power travel through the display.
- **Service and Diagnostics:** provides instructions for removing various display components and explains the functions of circuit board connectors and the meanings of any diagnostic LEDs.
- **Maintenance:** lists a number of steps to take to keep this Galaxy display in safe, working order.
- **Troubleshooting:** lists some possible display malfunctions and provides a number of possible causes for that malfunction.
- **Replacement Parts Lists:** lists the part description and part number of display components that could possibly need replacing during the life of this display.
- **Exchange/Repair & Return Programs:** explains Daktronics component return policy.

## 4.2 Signal Summary

---

### Reference Drawings:

System Riser Diagram, RS232.....	<b>Drawing A-96058</b>
System Riser Diagram, RS422.....	<b>Drawing A-92681</b>
System Riser Diagram, Modem.....	<b>Drawing A-88426</b>
System Riser Diagram, Fiber.....	<b>Drawing A-110559</b>
Schematic .....	<b>Appendix B</b>

The signal routing for the display can be summarized as follows.

1. Data from the controller computer, which runs Venus 1500 software, travels via RS232, RS422, modem or fiber optic cable into the display.
2. For multiple face display or a display network, an RS422 (most typical) or fiber cable relays signal between the controller of the first display and the controller in the second display.
3. From the controller, the signal then travels over a 40-conductor ribbon cables from the controller (J11 through J16 provide signal out) to J2 on the driver of the first column of modules in the display.
4. Data exits at J1 and is relayed to J2 of the next driver board and so on, traveling down the entire row of modules. The drivers use this display data to control the LEDs.

### 4.3 Power Summary

---

**Reference Drawing:**

Schematic ..... **Appendix B**

The power routing for the display can be summarized as follows.

1. Incoming power terminates at the power termination enclosure. Before leaving the enclosure, power is sent through a circuit breaker and an RFI electrical filter.
2. Power for the controller board passes through a transformer located on the controller/power panel.
3. Depending on display size, either +6.5VDC or +9VDC power supplies are used to power the modules. Power supplies are preset. Contact Daktronics Customer Service for the proper settings.
4. In Galaxy displays, the 9VDC power supply powers the green and blue LEDs through the 4-pin connector. The 6.5VDC power supply powers the red LEDs and driver's logic circuit through 2-pin connectors.

### 4.4 Service & Diagnostics

---

**Reference Drawings:**

Signal Input, Venus 1500 ..... **Drawing A-129110**  
 Assy, Power Supply A-1633 @2, A-1591 ..... **Drawing A-148636**  
 Entrance Box 8/16..... **Drawing A-149160**  
 Assy, Power Box 2 Position..... **Drawing A-155736**  
 Exploded Front, Module ..... **Drawing B-126111**  
 Exploded Rear, Module ..... **Drawing B-126112**  
 Component Layout Diagram..... **Appendix B**  
 Schematic ..... **Appendix B**

The following sub-sections address servicing of the following display components:

- transformer, RFI filter
- controller
- modules, drivers and power supplies

The sub-sections also address any diagnostic LEDs, fuses and signal/power connectors found on the unit. On the **Schematics** and **Component Layout Diagrams**, the components are denoted as follows.

Component...	Denoted As...	Location...
Filter & Transformer	0A-1241-4002	Inside the power termination box
Controller	0A-1146-0067	Inside the controller/power panel (behind the bottom left module)
Modules	Squares (0A-1208-2551) A101 through A418	Over entire face of the display (includes driver)
Power Supplies	0A-1241-4001 0A-1213-4034	Behind modules (refer to your display's schematic)
Light Detector	0A-1241-4001	Behind the bottom left module
Modem	0P-1146-0003	Refer to the display's schematic
Fiber Board	0P-1127-0024	Refer to the display's schematic

## Transformer & RFI Filter

**REMEMBER:** DISCONNECT POWER BEFORE SERVICING ANY INTERNAL COMPONENTS.

### Transformer

The transformer is located in the upper portion of the power termination box (T1 in **Drawing A-149554**). To replace the transformer, first disconnect all the wires attached to it. *Turn off power to the display before removing the wires.* Then release the hardware securing it to the inside of the enclosure. Position the new transformer in its place, and tighten it down. Reconnect all the wires using the display's schematic as a reference.

### RFI Filter

The RFI electrical filters are mounted above and to the side of the power termination box (Z1 and Z2 in **Drawing A-149554**). Like the transformer, the filters can be replaced by first removing all connecting wires, then releasing the attachment hardware. Install the new filter using the display's schematic as a wiring reference.

### Controller

The controller sends data to the modules. Refer to the signal summary in **Section 4.2** for more information and to the component location drawings for the position of the controller board.

**Figure 21** illustrates a typical controller.

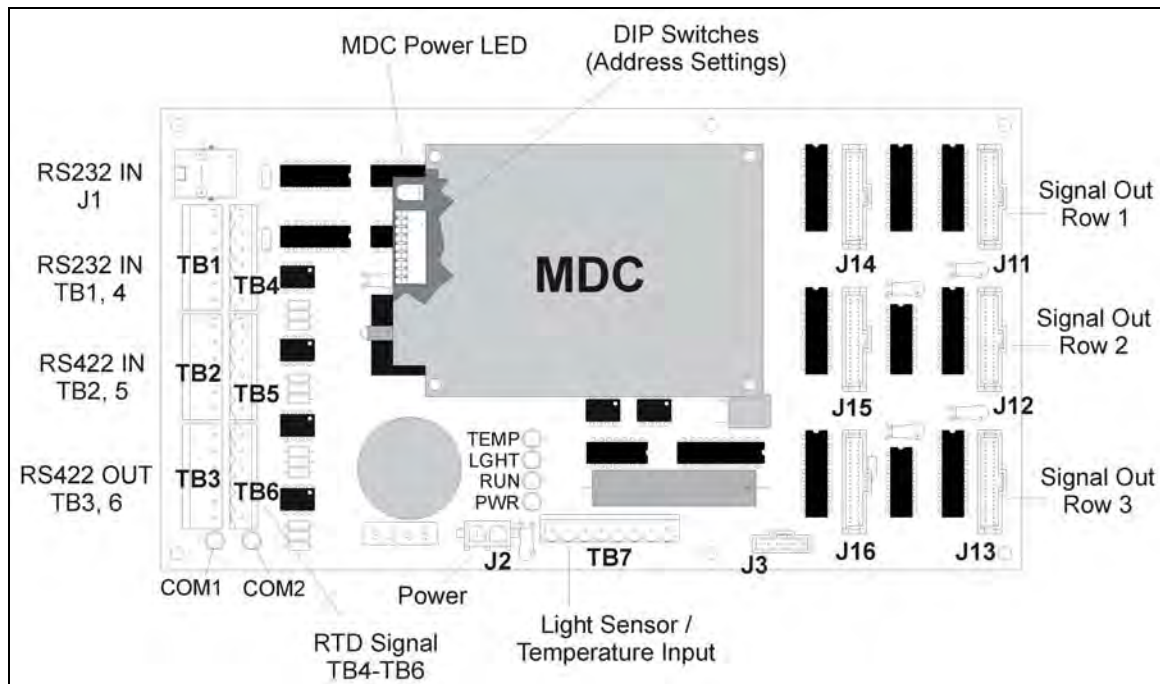

**Figure 21:** Controller Component Layout

“DIP” switches are located on the controller's MDC. The DIP switches set the hardware address, which the software uses to identify that particular display. When replacing a controller board, be sure to set the DIP switches in the same address configuration as the defective controller.

**Note:** Setting the DIP switches to address 0 (turn all the switches to OFF by flipping them toward the printed switch numbers) can activate a test mode. The display's power must be turned off and then turned back on to run the test mode.

Switch 8	Switch 7	Switch 6	Switch 5	Switch 4	Switch 3	Switch 2	Switch 1	Address
Off	Off	Off	Off	Off	Off	Off	Off	Test Mode
Off	Off	Off	Off	Off	Off	Off	On	1
Off	Off	Off	Off	Off	Off	On	Off	2
Off	Off	Off	Off	Off	Off	On	On	3
Off	Off	Off	Off	Off	On	Off	Off	4
Off	Off	Off	Off	Off	On	Off	On	5
Off	Off	Off	Off	Off	On	On	Off	6
Off	Off	Off	Off	Off	On	On	On	7
...	...	...	...	...	...	...	...	...
On	On	On	On	Off	Off	Off	Off	240

Four diagnostic LEDs are located on the controller; the table below tells what each LED denotes.

LED	Color	Function	Operation	Summary
TEMP	Red	Temperature Level	Flashes	Flash rate is dependent upon the temperature. Flashes faster in high temperature and slows as the temperature decreases.
LGHT	Red	Photocell Light Level	Flashes	Flash rate is dependent on the light level. Flashes faster in bright light and slows as darkness descends.
RUN	Red	Controller	Steady Flash	A steady flash indicates the controller is running correctly. Normal flash rate is about once a second.
PWR	Green	Power	Always On	Power to the data input circuit when lit.
RX1	Yellow	Com 1	Flashes	Turns on and flashes when receiving information.
RX2	Yellow	Com 2	Flashes	Turns on and flashes when receiving information, typically used in custom applications.

The controller contains two jumpers (W1 and W2) for use with a modem system. *The jumpers must jump both pins for a modem system.*

Complete the following steps to remove the controller from the display.

1. Disconnect power from J2.
2. Remove all power and signal connections from the board. "Locked" connectors are released by squeezing together the tabs, then carefully pulling them from the jack. When replacing the board, it is helpful to have the cables labeled as to which was removed from which connector.
3. Remove each of the six nuts holding the board in place.
4. Follow the previous steps in reverse order to install a new controller board.

### Modules & Drivers

The module and driver board are a single functional unit. The LED power supplies are identified as assemblies (refer to **Power Supplies**, following in this section). Each power supply unit controls four modules; a power supply assembly (two power supply units) controls eight.

To remove a module, complete the following steps:

1. Locate the latch access fasteners on the module. One is centered below the top row of pixels and one is centered above the bottom row.
2. With a 1/8" Allen wrench, turn the latch access fasteners a quarter turn as seen in **Figure 22**. The top one should be turned clockwise and the bottom one counter-clockwise.
3. Pull the display module far enough to reach around the back and disconnect the ribbon cables.

When installing a module, reverse the previous steps and take note of the following points:

- The weather-stripping on the back edge of the module must be intact and in good condition if it is to prevent water from seeping into the display.
- The module latches must be fully engaged to create a watertight seal around the edge of the module. The module should be firmly seated against the display when the latches are fully engaged.

Each module assembly is made up of a module housing (containing LEDs and the driver) and a louver assembly. **Drawings B-126111** and **B-126112** illustrate the various module components.

From time to time, it may become necessary to remove one or more parts from the module housing for repair or replacement. The following sub-sections explain how to disassemble a module.

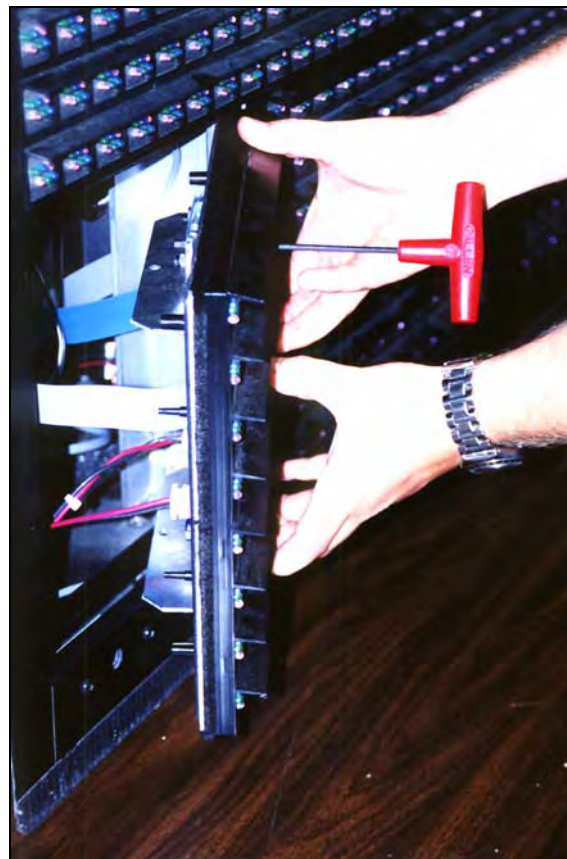

**Figure 22:** Removing a Module

### **Removing the Louver Assembly**

Complete the following steps to remove the louver assembly from the face of the module.

1. From the backside of the module, remove the five twist-on fasteners holding the louver assembly to the module.
2. Lift the louver assembly straight away from the module.

Damaged louvers may reduce the brightness and contrast of this display. If any of the louvers on the display are broken or damaged, the entire louver assembly must be replaced. Refer to the Replacement Parts List in **Section 4.11**. When replacing the louver assembly take care not to strip the plastic twist-on fasteners.

### **Power Supplies**

The LED power supplies are identified as assemblies 0A-1241-4001 in the component location drawings.

Complete the following steps to remove a power supply from the display:

1. Remove the module directly in front of the failed power supply.
2. Disconnect all the wires connected to the power supply.
3. Remove the hardware holding the power supply in place to free the unit.
4. Follow these steps in reverse order to install a new power supply. Refer to the display's **Schematic** when reconnecting the wires.

### Light Detector

The light detector is internally mounted and wired at Daktronics. It is located in the bottom left corner on the front of the display (identified as assembly 0A-1241-4001 (LT) in the **Component Layout Diagram**). A 4-conductor cable connects the light detector to the controller board. The cable is terminated at the terminal block on the light sensor and at TB7 on the controller board (refer to your display's schematic).

Light Detector Pin No.	Cable Wires Color	Controller Board TB7 Pin No.
1	Green	3
2	White	4
3	Red	1
4	Black	2
N.C.	Shield	2

### Modem

If a modem was included with the display, it is located inside the display next to the controller board.

1. To replace a modem, first disconnect the power and signal connections (refer to **Figure 23** for the location of the power jack).
2. The modem is held in place with four screws. Remove the screws and lift the modem out of the display.
3. Attach the new modem using the same four screws removed in step 2, above.

The modem module has two LEDs. The Power LED should remain lit while power is applied to the modem. The Active LED will light when the modem is in the process of communicating.

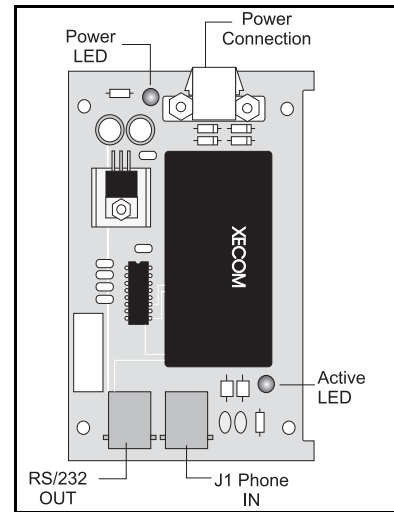

Figure 23: Modem

A modem system requires jumpers to be set on the controller board. Refer to the **Controller** section for the jumper settings.

### Fiber Board

The fiber module has three LEDs. The power LED (DS1) should remain lit while power is applied to the module. The receive LED (DS2) will light when the display fiber board is accepting signal from the computer fiber board. The transmit LED (DS3) will light when the display fiber board is sending to the computer fiber board. In addition, the fiber module has two input fiber connectors, which the computer or the previous display connects to, and two output fiber connectors that connect to the next display. The fiber board connects to the controller board with a small DB9 adapter and straight through RJ11 cable.

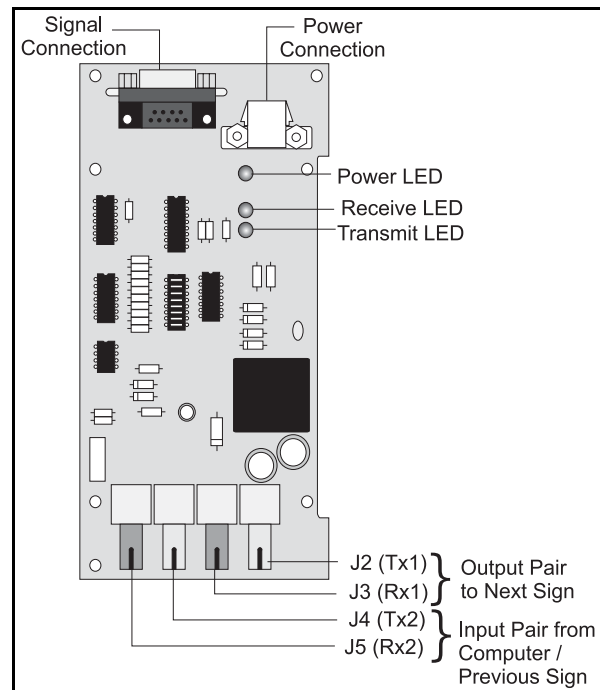

Figure 24: Fiber Optic Board



To replace a fiber optic board:

1. Disconnect the power and signal connections (refer to **Figure 24** for disconnection of power).
2. The fiber optic board is held in place with four screws. Carefully remove them.
3. Install the new fiber board, replace the screws and reconnect power and signal cables.

## 4.5 Ventilation Systems (With Fans and Filters)

---

Ventilation fans should be checked after 1,500 hours of operation and every 1,500 hours after that to ensure the display is being cooled properly. Fans should be checked more often if the display is located in a dusty or harsh weather environment (i.e. along a gravel road with dust laden air).

- 1,500 hours is equivalent to 83 days if the display is operated for 18 hours a day and the power to the display is turned off when not in use.
- 1,500 hours is equivalent to 62 days if the display is running non-stop for 24 hours a day.

Each time a module is removed, for whatever reason, take a minute to inspect the fans.

- Check the fan blades for dirt and debris. If the fan blades have a large accumulation of dirt and debris, this indicates that the filters must be changed more often. Fan blades must be kept clean to maintain fan efficiency and ensure proper cooling.
- Spin the fan blades with a pen or pencil to ensure that the bearings are free and the fan is still in balance.

To check the operation of the fans, push the bypass button (momentary contact) on the thermostat enclosure to temporarily turn the fans on:

- Hold your hand or a piece of light paper beneath the display to detect air movement.
- If the fan does not turn or does not operate smoothly, replace it. It is located behind A102, top row, second module from the left.

Filters must be checked once a year or after every 1,500 hours of operation, whichever comes first.

Filters can be cleaned with water and a mild detergent, such as dish soap. Compressed air can also be used to clean the filters provided the nozzle is held at least six inches away from the filter, the pressure is no greater than 60 psi and the air is blown through the filter in the opposite direction from which air normally flows. The arrow stamped on the frame filter indicates air flow direction.

## 4.6 Thermostats

---

### Reference Drawings:

Component Layout Diagram..... **Appendix B**

A thermostat controls when the ventilation fans are turned on in the display. Refer to the **Component Layout Diagram** for the location of the thermostat. The ventilation fans turn on when the inside of the display reaches 85° F (29° C), and turn off at 70° F (21° C).

## 4.7 Weather Stripping

---

To ensure that the display is waterproof, weather stripping has been provided around the entire display and around each module. It is important that the weather stripping is installed properly at all times or water may leak into the display and damage the components.

## 4.8 Display Maintenance

---

A yearly inspection should be completed to maintain safe and dependable display operation. This inspection should address the following issues.

- **Loose Hardware**  
Verify fasteners, such as bolts and rivets, have not come loose. Fasteners should be checked and tightened or replaced as required.
- **Excessive Dust Buildup**  
Occasionally it may be necessary to vacuum the inside of the display cabinet to remove dust/dirt buildup that may interfere with airflow.
- **Water Intrusion – Water Stain Marks**  
Water can enter the display where weather stripping has come loose or deteriorated or where fasteners have come loose allowing gaps in the panels or where moisture may be entering around hardware. Check electronic components for displays of corrosion.
- **Corrosion**  
Check the paint, and look for possible corrosion especially at footings, structural tie points and ground rods.

**If any of the above conditions are noticed, action must be taken to correct the situation.**

## 4.9 Troubleshooting

---

This sub-section contains some symptoms that may be encountered in the displays. This list does not include every possible symptom, but does represent common situations that may occur.

Symptom/Condition	Possible Cause/Remedy
One or more LEDs on a single module fail to light.	<ul style="list-style-type: none"><li>• Replace/check ribbon cables on the module.</li><li>• Replace the module.</li></ul>
One or more LEDs on a single module fail to turn off.	<ul style="list-style-type: none"><li>• Replace/check ribbon cables on module.</li><li>• Replace the module.</li></ul>
A section of the display is not working. The section extends all the way to the right side of the display.	<ul style="list-style-type: none"><li>• Replace the first module/driver on the left side of the first module that is not working.</li><li>• Replace the second module that is not working.</li><li>• Replace the power supply assembly on the first module that is not working.</li><li>• Replace the ribbon cable.</li></ul>
One row of modules does not work or is garbled.	<ul style="list-style-type: none"><li>• Replace first module.</li><li>• Replace controller.</li><li>• Check the fuses in the power termination box.</li></ul>
A group of modules, which share the same power supply assembly, fail to work.	<ul style="list-style-type: none"><li>• Replace the power supply assembly.</li></ul>
Entire display fails to work.	<ul style="list-style-type: none"><li>• Check for proper line voltage into the power termination panel.</li><li>• Check/replace the ribbon cable from the controller to the modules.</li><li>• Check the voltage settings on the power supplies.</li><li>• Check/replace the signal cable to the controller.</li><li>• Replace the controller.</li><li>• Verify proper use of the software in the operation manual.</li></ul>
Temperature always reads 32 degrees F/0 degrees C	<ul style="list-style-type: none"><li>• Check temperature sensor connections.</li><li>• Replace the temperature sensor.</li><li>• Replace the controller.</li></ul>

Display is stuck on bright or dim.	<ul style="list-style-type: none"> <li>• Check Manual/Auto dimming in Venus 1500 software.</li> <li>• Check light detector cable.</li> <li>• Check light detector for obstructions.</li> <li>• Replace the light detector.</li> <li>• Replace the controller.</li> </ul>
------------------------------------	--

#### 4.10 Boot Up Initialization Information

---

Every time the display is powered up, the display will run through an initialization in which it will display the following:

1. Output Test (DDDs)
2. Product Name (Galaxy)
3. Display Size (Row x Column)
4. Firmware Number (**ED-12699**)
5. Firmware Revision (Rev X.XX)
6. COM1 Configuration (C1: V15/RTD)
7. COM2 Configuration (C2: None)
8. Line Frequency (60 Hz)
9. Hardware Address (HW: XX)
10. Software Address (SW: XX)
11. Display Name
12. Modem (If modem is present)

#### 4.11 Replacement Parts List

---

The following tables contain some of the items that may need to be replaced in these displays over a period of time. Many of the parts within the display also list their part numbers on labels affixed to them.

To prevent theft Daktronics recommends purchasing a lockable cabinet to store manuals and replacement/spare parts.

Part Description	Part Number
Controller II, 48x168, Louvered Galaxy	0A-1146-0067
Module, 2R2G2B (1:1) 8x8 (30x70) Type 1	0A-1208-2551
Power Supply Assembly, 2 A-1633, 1 A-1591	0A-1241-4001 & 0A-1213-4034
Thermostat Enclosure 85-70-9L	0A-1213-4024
Light Level Detector; 34mm	0A-1215-4001
Filter; Air, Gasket, 7.50" x 13.50" x .88"	EN-1774
Fan; 250CFM, 115VAC, 0.65A, 5.84x6.0"	B-1019
Transformer; Pri 115V, Sec 10VCT@1.2A (120V Displays)	T-1072
Transformer; 115/240V Pri 10VCT@1.2A (240V Displays)	T-1106
Filter, RFI Line 10 AMP 120 VAC	Z-1007
Fan Finger Guard (for B-1019 fan)	HS-1130
Fuse Holder; 1 Pos. Pnl Mt. ¼"	X-1032
Thermostat; SPST NO Close 85 Open 70	S-1144
Modem Board; 232 Coated	OP-1146-0003
Fiber Board; RS232 to Fiber, 12V	OP-1127-0024
Jack; 6-Pin Female for Modem	J-1094
Cable; 18" RJ11; 6-Cond.	0A-1137-0160
Signal Converter (RS232/RS422)	0A-1127-0237

Signal Converter (RS232/Fiber)	0A-1127-0239
Manual; Venus 1500 Operator's, Version 2.0	ED-12717
Manual; Galaxy Outdoor 34mm Louvered Displays	ED-12835
Ribbon Cable; 40 Cond. 30 AWG 18" (Controller to Module, Module to Module)	W-1412
Ribbon Cable Assy; 40 Pos, 66"	W-1439
Ribbon Cable Assy; 40 Pos, 36"	W-1423
Cable; 22 AWG (Light Sensor/Temp Sensor to Controller)	W-1234
Flipped PC Connector; DB9F/RJ11F	0A-1146-0029
Digital Temp Sensor	0P-1151-0003
Electrical Contact Cleaner Lubricant / Cal-Lube	CH-1019

## 4.12 Daktronics Exchange/Repair & Return Programs

---

To serve customers' repair and maintenance needs, Daktronics offers both an exchange and a repair and return program. The exchange program reduces down time by providing timely replacement of key components. This service is provided to qualified customers who follow the program guidelines explained below. It is our pleasure to provide this service to ensure you get the most from your Daktronics products. Please call our Help Desk (1-877 / 605-1113) if you have any questions regarding the exchange program or any other Daktronics service.

When you call the Daktronics Help Desk, a trained service technician will work with you to solve the equipment problem. You will work together to diagnose the problem and determine which exchange replacement part to ship. If, after you make the exchange, the equipment still causes problems, please contact our Help Desk immediately.

If the replacement part fixes the problem, package the defective part in the same packaging the replacement part arrived in, fill out and attach the enclosed UPS shipping document and **RETURN THE PART TO DAKTRONICS**. (You may use the same box and packing the exchange part was sent in.) This will speed up the transaction and alleviate confusion when the failed component arrives at Daktronics. (Daktronics expects immediate return of the exchange part if it does not solve the problem.) For most equipment, you will be invoiced for the replacement part at the time it is shipped. This invoice is due when you receive it.

Daktronics reserves the right to refuse equipment that has been damaged due to acts of nature or causes other than normal wear and tear.

*If the defective equipment is not shipped to Daktronics within 30 working days from the invoice date, it is assumed you are purchasing the replacement part and you will be invoiced for it.* This second invoice represents the difference between the exchange price and the purchase price of the equipment. This amount is due when you receive the second invoice. If you return the exchange equipment after 30 working days from invoice date, you will be credited for the amount on the second invoice minus a restocking fee.

**☞To avoid a restocking charge, please return the defective equipment within 30 days from the invoice date.**

Daktronics also offers a Repair and Return program for items not subject to exchange.

**Where to Send:** To return parts for service, contact your local representative prior to shipment to acquire a Return Material Authorization Number (RMA#). If you have no local representative, call the Daktronics Help Desk for the RMA#. This will expedite the receiving process.

**Packaging for Return:** Package and pad the item well so that it will not be damaged in shipment.

Electronic components such as printed circuit boards should either be installed in an enclosure or should be put in an anti-static bag before boxing. Please enclose your name, address, phone number and a clear description of symptoms.

**Mail:** Daktronics, Inc., Customer Service  
PO Box 5128  
331 32nd Avenue  
Brookings, SD 57006

**Phone:** Daktronics Help Desk: 1-877/605-1113  
or 1-605/697-4034

**Customer Service Fax:** 1-605-697-4444

**e-mail:** [helpdesk@daktronics.com](mailto:helpdesk@daktronics.com)



# Appendix A: Signal Converter

The following table gives the typical state of the signal converter when the LEDs are either on or off. Refer to **Figure 25** for an illustration of the signal converters and the locations of the various components.

LED Indicators	Typical States	
PWR	ON	Signal Converter (SC) is receiving power.
	OFF	SC is not receiving power. Internal 1 AMP Fuse is bad.
TX	ON Steady	SC is not connected to a serial port. (If connected to serial port) Serial port or serial cable may be bad.
	OFF Steady	Normal state, SC is not transmitting data.
	Brief Flicker	SC is transmitting data.
RX	ON Steady	Field cabling between SC and display is bad, connected to display out or terminated incorrectly.
	OFF Steady	Normal state, SC is not receiving data.
	Brief Flicker	SC is receiving data.

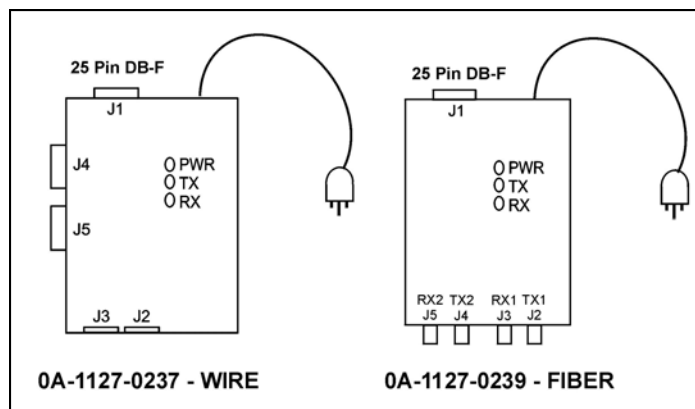

**Figure 25:** Signal Converters

## 0A-1127-0237 – Wire

The following tables list the jack pin-outs for a wire signal converter.

J2 & J3 - RJ/11	
PIN	OPERATION
1	GND
2	TX-N (out)
3	TX-P (out)
4	RX-N (in)
5	RX-P (in)
6	GND

J4 & J5 – Phoenix	
PIN	OPERATION
1	GND
2	RX-P (in)
3	RX-N (in)
4	TX-P (out)
5	TX-N (out)
6	GND

J1 25 Pin DB-F	
PIN	OPERATION
2	TX-P (out)
3	RX-P (in)
7	GND

**Loop-Back Test:** To perform a loop-back, for testing purposes only, connect the following using copper conductor jumpers.

**Note:** This test should be performed with only one jack at a time. Do not connect loop back to more than one jack at a time.

<b>J2 &amp; J3</b>	<b>OR</b>	<b>J4 &amp; J5</b>
TX-N to RX-N		RX-P to TX-P
TX-P to RX-P		RX-N to TX-N

### 0A-1127-0239 – Fiber

The following tables give the jack pin-outs for a fiber signal converter.

JACK	OPERATION
J2	TX1 (out)
J3	RX1 (in)
J4	TX2 (out)
J5	RX2 (in)

J1 – 25 Pin DB-F	
PIN	OPERATION
2	TX-P (out)
3	RX-P (in)
7	GND

**Loop-Back Test:** To perform a loop-back, for testing purposes only, connect the following using a fiber optic cable jumper.

<b>J2 &amp; J3 or J4 &amp; J5</b>
TX to RX

### Serial Cable (W-1249)

This table lists the pin connections when using a serial cable (W-1249).

DB9-F	DB25-F
Pin 3 – TX	Pin 2 – TX
Pin 2 – RX	Pin 3 – RX
Pin 5 – GND	Pin 7 - GND

### Serial Adaptor (A-1603)

DB9-F	DB25-M
Pin 3 – TX	Pin 2 – TX
Pin 2 – RX	Pin 3 – RX
Pin 5 – GND	Pin 7 - GND



# Appendix B: Reference Drawings

---

Refer to **Section 1.1** for information on reading drawing numbers. The following drawings are listed in numerical order by size (A, B, etc.)

Temp Sensor Mounting .....	Drawing A-79767
System Riser Diagram, Modem.....	Drawing A-88426
System Riser Diagram, RS422.....	Drawing A-92681
System Riser Diagram, RS232.....	Drawing A-96058
System Riser Diagram, Fiber .....	Drawing A-110559
Schematic; Fiber/Modem Input.....	Drawing A-125900
Mtg Clip Angles; AX-XXXX-40/48XXX-34B .....	Drawing A-128799
Clip Angle Mounting; AX-XXX-8/32XX-34B .....	Drawing A-128801
Signal Input, Venus 1500 .....	Drawing A-129110
Power Specs, 8x144 Display, RGB .....	Drawing A-148571
F. Assy, AF-3065-32***-34 .....	Drawing A-148630
Assy, Power Supply A-1633 @2, A-1591 .....	Drawing A-148636
Entrance Box 8/16.....	Drawing A-149160
Comp. Layout Diagram; AF-3065-848-34-RGB.....	Drawing A-149301
Comp. Layout Diagram; AF-3065-864-34-RGB.....	Drawing A-149309
Comp. Layout Diagram; AF-3065-880-34-RGB.....	Drawing A-149310
Comp. Layout Diagram; AF-3065-896-34-RGB.....	Drawing A-149311
Comp. Layout Diagram; AF-3065-8112-34-RGB.....	Drawing A-149312
Comp. Layout Diagram; AF-3065-8128-34-RGB.....	Drawing A-149315
Comp. Layout Diagram; AF-3065-8144-34-RGB.....	Drawing A-149317
Comp. Layout Diagram; AF-3065-1648-34-RGB.....	Drawing A-149321
Comp. Layout Diagram; AF-3065-1664-34-RGB.....	Drawing A-149330
Comp. Layout Diagram; AF-3065-1680-34-RGB.....	Drawing A-149333
Comp. Layout Diagram; AF-3065-1696-34-RGB.....	Drawing A-149334
Comp. Layout Diagram; AF-3065-16112-34-RGB.....	Drawing A-149336
Comp. Layout Diagram; AF-3065-16128-34-RGB.....	Drawing A-149342
Comp. Layout Diagram; AF-3065-16144-34-RGB.....	Drawing A-149347
Comp. Layout Diagram; AF-3065-2448-34-RGB.....	Drawing A-149349
Comp. Layout Diagram; AF-3065-2464-34-RGB.....	Drawing A-149357
Comp. Layout Diagram; AF-3065-2480-34-RGB.....	Drawing A-149359
Comp. Layout Diagram; AF-3065-2496-34-RGB.....	Drawing A-149361
Comp. Layout Diagram; AF-3065-24112-34-RGB.....	Drawing A-149364
Comp. Layout Diagram; AF-3065-24128-34-RGB.....	Drawing A-149365
Comp. Layout Diagram; AF-3065-24144-34-RGB.....	Drawing A-149368
Comp. Layout Diagram; AF-3065-3248-34-RGB.....	Drawing A-149402
Comp. Layout Diagram; AF-3065-3264-34-RGB.....	Drawing A-149407
Comp. Layout Diagram; AF-3065-3280-34-RGB.....	Drawing A-149408
Comp. Layout Diagram; AF-3065-3296-34-RGB.....	Drawing A-149420
Comp. Layout Diagram; AF-3065-32112-34-RGB.....	Drawing A-149421
Comp. Layout Diagram; AF-3065-32128-34-RGB.....	Drawing A-149422
Comp. Layout Diagram; AF-3065-32144-34-RGB.....	Drawing A-149427
Comp. Layout Diagram; AF-3065-4048-34-RGB.....	Drawing A-149429
Power Termination Box.....	Drawing A-149554
Comp. Layout Diagram; AF-3065-4064-34-RGB.....	Drawing A-149460
Comp. Layout Diagram; AF-3065-4080-34-RGB.....	Drawing A-149466
Comp. Layout Diagram; AF-3065-4096-34-RGB.....	Drawing A-149467
Comp. Layout Diagram; AF-3065-40112-34-RGB.....	Drawing A-149468

Comp. Layout Diagram; AF-3065-40128-34-RGB.....	<b>Drawing A-149471</b>
Comp. Layout Diagram; AF-3065-40144-RGB.....	<b>Drawing A-149472</b>
Comp. Layout Diagram; AF-3065-4848-34-RGB.....	<b>Drawing A-149477</b>
Comp. Layout Diagram; AF-3065-4864-34-RGB.....	<b>Drawing A-149477</b>
Comp. Layout Diagram; AF-3065-4880-34-RGB.....	<b>Drawing A-149479</b>
Comp. Layout Diagram; AF-3065-4896-34-RGB.....	<b>Drawing A-149480</b>
Comp. Layout Diagram; AF-3065-48112-34-RGB.....	<b>Drawing A-149482</b>
Comp. Layout Diagram; AF-3065-48128-34-RGB.....	<b>Drawing A-149483</b>
Comp. Layout Diagram; AF-3065-48144-34-RGB.....	<b>Drawing A-149484</b>
F. Assy, AF-3065-24**-RGB-34 .....	<b>Drawing A-149929</b>
F. Assy, AF-3065-8**-RGB-34 .....	<b>Drawing A-149939</b>
F. Assy, AF-3065-16**-RGB-34 .....	<b>Drawing A-149968</b>
F. Assy, AF-3065-40**-RGB-34 .....	<b>Drawing A-150660</b>
F. Assy, AF-3065-48**-RGB-34 .....	<b>Drawing A-150661</b>
Power Connection, AF-306X.....	<b>Drawing A-154965</b>
Assy, Power Box 2 Position .....	<b>Drawing A-155736</b>
Detail, Controller and Power Term Box 24-48 High.....	<b>Drawing A-156086</b>
Exploded Front View, Single Panel Module.....	<b>Drawing B-126111</b>
Exploded Rear View, Single Panel Module .....	<b>Drawing B-126112</b>
Shop Drawing, AF-3065-8-32 High .....	<b>Drawing B-148418</b>
Shop Drawing; AF-3065-40-48 High .....	<b>Drawing B-148419</b>
Schematic, AF-3065-24x***-9, RGB.....	<b>Drawing B-149403</b>
Schematic, AF-3065-8x***-9, RGB.....	<b>Drawing B-149469</b>
Schematic, AF-3065-16/32/48x***-9, RGB .....	<b>Drawing C-149070</b>
Schematic, AF-3065-40x***-9, RGB.....	<b>Drawing C-149437</b>

THERE SHOULD BE AT LEAST 1 FT BETWEEN THE BOTTOM OF THE EAVE AND THE TOP OF THE TEMP SENSOR HOUSING FOR ACCURATE READINGS.

TEMP SENSOR HOUSING (SUPPLIED BY DAKTRONICS)

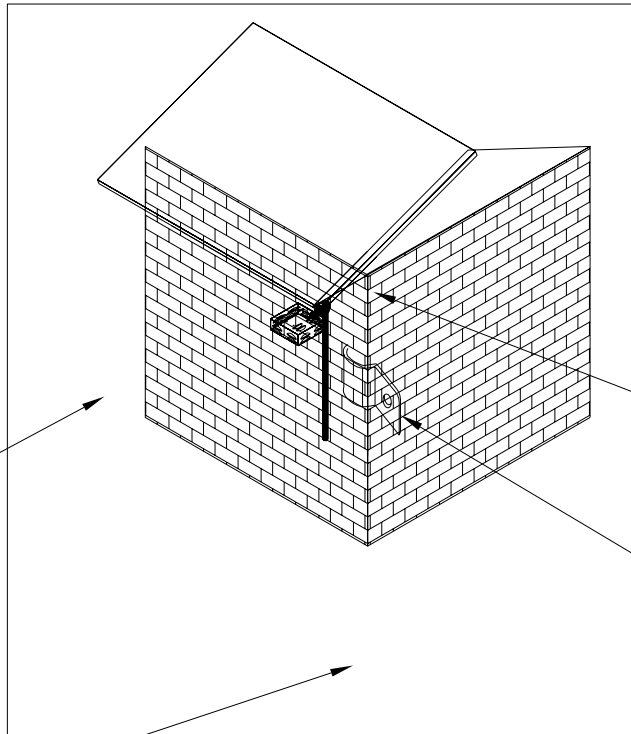

CONDUIT OUTLET BODY (SUPPLIED BY DAKTRONICS)

INSURE THAT CONDUIT IS SUPPORTED AT TOP END NEAR SENSOR.

1/2" CONDUIT (SUPPLIED BY CUSTOMER)

EAVE/WALL MOUNT

BOTTOM OF DISPLAY

1 FT OF 1/2" CONDUIT (SUPPLIED BY CUSTOMER)

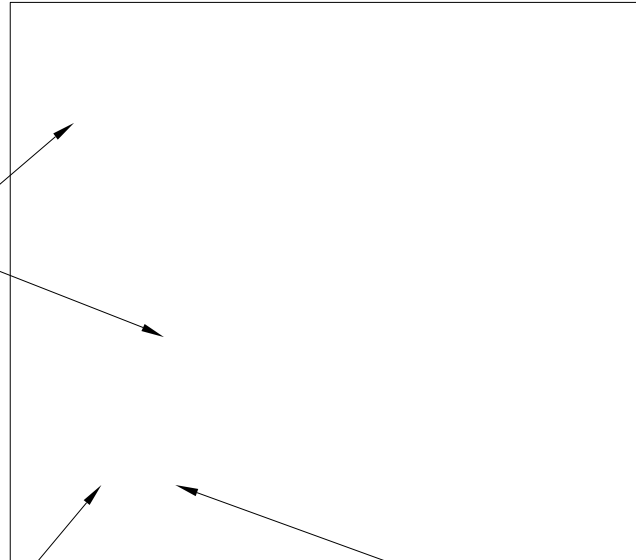

MOUNTING TO THE TOP OF THE DISPLAY IS DONE IN THE SAME MANNER EXCEPT THE CONDUIT HAS TO BE 6 FT LONG.

TEMP SENSOR HOUSING (SUPPLIED BY DAKTRONICS)

CONDUIT OUTLET BODY (SUPPLIED BY DAKTRONICS)

MOUNTING TO BOTTOM OF DISPLAY

THE CONCEPTS EXPRESSED AND DETAILS SHOWN ON THIS DRAWING ARE CONFIDENTIAL AND PROPRIETARY. DO NOT REPRODUCE BY ANY MEANS, INCLUDING ELECTRONICALLY WITHOUT THE EXPRESSED WRITTEN CONSENT OF DAKTRONICS, INC. COPYRIGHT 2003 DAKTRONICS, INC.

DAKTRONICS, INC. BROOKINGS, SD 57006

PROJ:

TITLE: TEMP SENSOR MOUNTING

DES. BY:

DRAWN BY: NJA

DATE: 20 MAR 96

REVISION

APPR. BY:

SCALE: NONE

1151-R11A-79767

REV.	DATE	DESCRIPTION	BY	APPR.
2	27DEC99	CLEANED UP DRAWING.	NJA	
1	19AUG98	ADDED CONDUIT CLAMP FOR EAVE/WALL MOUNT	JRT	

REV.	DATE	DESCRIPTION	BY	APPR.
8	23 FEB 07	ADDED REFERENCE TO MANUALS AND DETAIL A & B (OPENED CHANGE - REMOVED DB25F COM PORT REFERENCES. ADDED AF-3080 AND AF-3090 TO CHART 1)	MLG	
7	06MAY02		TJN	

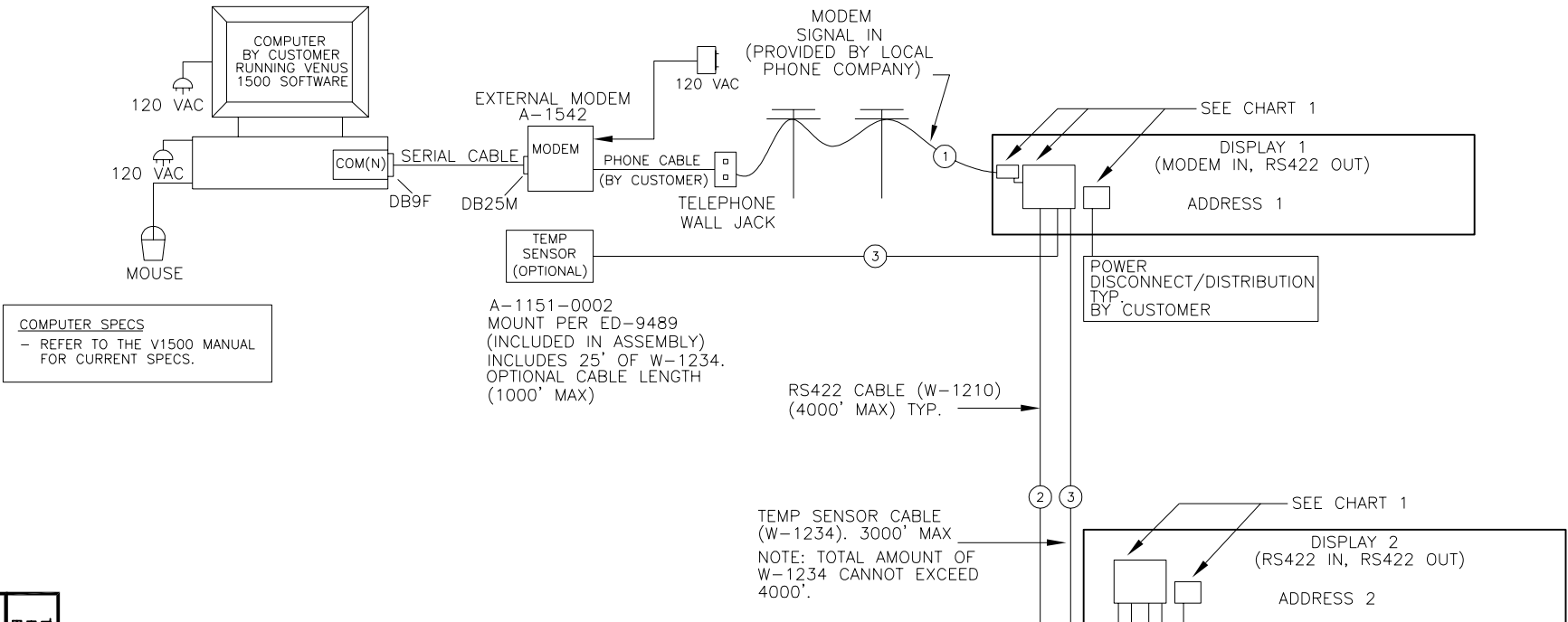

**COMPUTER SPECS**  
 - REFER TO THE V1500 MANUAL FOR CURRENT SPECS.

A-1151-0002  
 MOUNT PER ED-9489  
 (INCLUDED IN ASSEMBLY)  
 INCLUDES 25' OF W-1234.  
 OPTIONAL CABLE LENGTH  
 (1000' MAX)

RS422 CABLE (W-1210)  
 (4000' MAX) TYP.

TEMP SENSOR CABLE  
 (W-1234). 3000' MAX  
 NOTE: TOTAL AMOUNT OF  
 W-1234 CANNOT EXCEED  
 4000'.

**NOTES**

- PHONE CABLE. BY CUSTOMER.
- 6 CONDUCTOR, 22 AWG, STRANDED SHIELDED CABLE. DAK. P.N. (W-1210). BELDON P.N. (9942) OR EQUIV. IN CONDUIT WHERE REQUIRED. FIELD SIGNAL TERMINATIONS TO BE PHOENIX TERMINAL BLOCKS. REFER TO DISPLAY MANUAL FOR TERMINATION. FIELD CABLES ARE "FLIPPED" FROM ONE END TO THE OTHER.
- 4 CONDUCTOR, 22 AWG, STRANDED SHIELDED CABLE. DAK. P.N. (W-1234). MANHATTAN P.N. (M4473) OR EQUIV. IN CONDUIT WHERE REQUIRED. FIELD SIGNAL TERMINATIONS TO BE PHOENIX TERMINAL BLOCKS. REFER TO DISPLAY MANUAL FOR TERMINATION. (OPTIONAL WITH TEMP SENSOR).
- MODEM CONTROL EQUIPMENT KIT INCLUDES:  
 W-1249.....SERIAL CABLE  
 A-1542.....EXTERNAL MODEM
- INPUT TO MODEM IS RS232.
- ALL SIGNAL CABLES BY CUSTOMER. LABOR TO PULL CABLES BY CUSTOMER.
- ALL POWER WIRES BY CUSTOMER. LABOR TO PULL WIRES BY CUSTOMER.
- ALL WIRING TO MEET NEC AND LOCAL ELECTRICAL CODES.  
 DISPLAYS MUST BE GROUNDED PER ARTICLE 250 AND 600 OF THE NATIONAL ELECTRICAL CODE.

**DETAIL: A**

FIELD CABLE	TB2 OF MODEM	MODEM TB2
COLOR	PIN	
TIP	1	
RING	2	

**DETAIL: B**

FIELD CABLE	J5 (RJ11) OF MODEM	MODEM J5
COLOR	PIN	
TIP	3	
RING	4	

CHART 1

DISPLAY TYPE	POWER CONN. DWG.#	SIGNAL CONN. DWG.#	POWER SPEC. DWG.#
AF-3020	A-140262	A-88427	A-154944
X-1000	A-140262	A-88427	A-154944

THE CONCEPTS EXPRESSED AND DETAILS SHOWN ON THIS DRAWING ARE CONFIDENTIAL AND PROPRIETARY. DO NOT REPRODUCE BY ANY MEANS, INCLUDING ELECTRONICALLY WITHOUT THE EXPRESSED WRITTEN CONSENT OF DAKTRONICS, INC. COPYRIGHT 2007 DAKTRONICS, INC.

DAKTRONICS, INC. BROOKINGS, SD 57006

PROJ: OUTDOOR LED PRODUCT LINE

TITLE: SYSTEM RISER DIAGRAM, MODEM

DES. BY: JCOOK

DRAWN BY: AMEYER

DATE: 21NOV96

REVISION

APPR. BY: NONE

1137-R01A-88426

1	12DEC96	ADDED NOTES FOR ADDITIONAL DISPLAY WIRING	JHC
2	27 MAY 98	DELETED ED'S FROM LIST OF PART NO.'S DELETED G-1000 FROM DISPLAYS & TITLE BLOCK MOVED TERM PANELS TO LOWER LEFT CORNER	JEM
3	06APR00	REPLACED ENTIRE DRAWING TO INCLUDE ALL OUTDOOR DISPLAYS.	LLK
4	27 OCT 00	CHANGED POWER CONN. DWG# FROM B-98318 TO A-140262. ADDED DISTRIBUTION TO DISCONNECT/DISTRIBUTION	LMH
5	30JUL01	CHANGED TEMP SENSOR TO OPTIONAL	LLK
6	27 AUG 01	ADDED DRAWINGS, AF-3060-RG, AND AF-3065 TO CHART 1.	DJM

REV.	DATE	DESCRIPTION	BY	APPR.
7	23 FEB 07	UPDATED CHART 1. REMOVED DB25F COM PORT REFERENCES & A-1127-0237 SIGNAL CONVERTER	MLG	
6	26 MAR 04	REPLACED 0A-1127-0237 WITH 0A-1127-0255 (INCLUDES SURGE PROTECTION)	SAI	DJM
5	06MAR02	ADDED AF-3080 AND AF-3090 TO CHART 1	TJN	

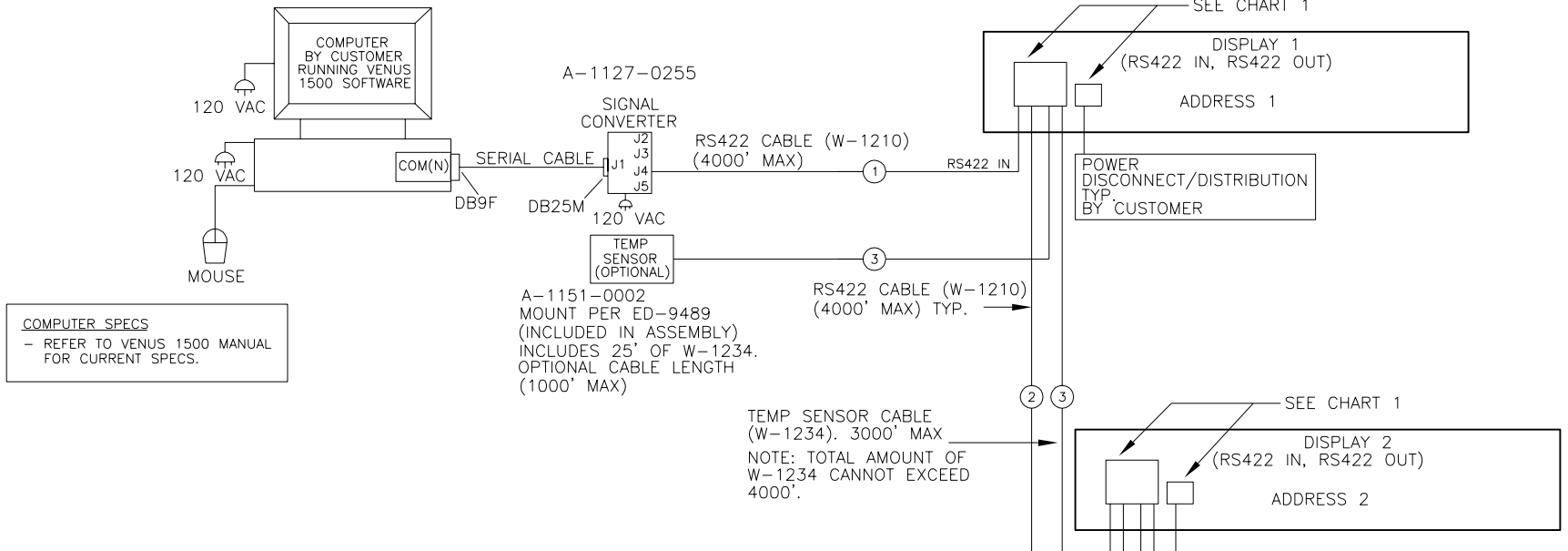

**COMPUTER SPECS**  
 - REFER TO VENUS 1500 MANUAL FOR CURRENT SPECS.

- NOTES
- 6 CONDUCTOR, 22 AWG, STRANDED SHIELDED CABLE, DAK, P.N. (W-1210). BELDON P.N. (9942) OR EQUIV. IN CONDUIT WHERE REQUIRED. FIELD SIGNAL TERMINATIONS TO BE PHOENIX TERMINAL BLOCKS. REFER TO DETAIL A FOR TERMINATION. FIELD CABLES ARE PINNED 1 TO 1 FROM ONE END TO THE OTHER.
  - 6 CONDUCTOR, 22 AWG, STRANDED SHIELDED CABLE, DAK, P.N. (W-1210). BELDON P.N. (9942) OR EQUIV. IN CONDUIT WHERE REQUIRED. FIELD SIGNAL TERMINATIONS TO BE PHOENIX TERMINAL BLOCKS. REFER TO DISPLAY MANUAL FOR TERMINATION. FIELD CABLES ARE "FLIPPED" FROM ONE END TO THE OTHER.
  - 4 CONDUCTOR, 22 AWG, STRANDED SHIELDED CABLE, DAK, P.N. (W-1234). MANHATTAN P.N. (M4473) OR EQUIV. IN CONDUIT WHERE REQUIRED. FIELD SIGNAL TERMINATIONS TO BE PHOENIX TERMINAL BLOCKS. REFER TO DISPLAY MANUAL FOR TERMINATION.
4. RS422 CONTROL EQUIPMENT KIT INCLUDES:  
 W-1249.....SERIAL CABLE  
 A-1127-0255.....SIGNAL CONVERTER
6. INPUT TO CONVERTER IS RS232, OUTPUTS RS422.
7. ALL SIGNAL CABLES BY CUSTOMER. LABOR TO PULL CABLES BY CUSTOMER.
8. ALL POWER WIRES BY CUSTOMER. LABOR TO PULL WIRES BY CUSTOMER.
9. ALL WIRING TO MEET NEC AND LOCAL ELECTRICAL CODES. DISPLAYS MUST BE GROUNDED PER ARTICLE 250 AND 600 OF THE NATIONAL ELECTRICAL CODE.

DETAIL: A

SIGNAL CONVERTER	J4 OR J5	FIELD CABLE	TB42 OF DISPLAY	TERMINAL BLOCK
	PIN	COLOR	PIN	
	1	RED	1	
	2	BLK	2	
	3	BRO	3	
	4	WHT	4	
	5	BLU	5	
	6	GRN	6	
		SHIELD	N.C	

CHART 1

DISPLAY TYPE	POWER CONN. DWG.#	SIGNAL CONN. DWG.#	POWER SPEC. DWG.#
AF-3020	A-140262	A-88427	A-154944
X-1000	A-140262	A-88427	A-154944

REV.	DATE	DESCRIPTION	BY	APPR.
4	27 AUG 01	REVISED COMPUTER SPEC BOX. ADDED DRAWINGS: AF-3060-RG, AND AF-3065 TO CHART 1.		DJM
3	27 OCT 00	CHANGED POWER CONN. DWG# FROM B-98318 TO A-140262. ADDED DISTRIBUTION TO DISCONNECT/DISTRIBUTION		LMH
2	06APR00	REPLACED ENTIRE DRAWING TO INCLUDE ALL OUTDOOR DISPLAYS		LLK
1	27 MAY 98	DELETED ED'S FROM LIST OF PART NO.'S. DELETED G-1000 FROM DISPLAYS. MOVED TERM PANELS TO LOWER LEFT CORNER		RK

PROJ: OUTDOOR LED PRODUCT LINE  
 TITLE: SYSTEM RISER DIAGRAM, RS422  
 DES. BY: JCOOK  
 DRAWN BY: AMEYER  
 DATE: 30APR97

REVISION 07  
 APPR. BY: NONE  
 SCALE: NONE  
 1137-R01A-92681

DAKTRONICS, INC. BROOKINGS, SD 57006

REV.	DATE	DESCRIPTION	BY	APPR.
1	27 MAY 98	DELETED ED'S FROM LIST OF PART NOS. & DELETED C-1000 FROM DISPLAYS & MOVED TERM PANELS TO LOWER LEFT CORNER	JEM	RK
2	06APR00	REPLACED ENTIRE DRAWING TO INCLUDE ALL OUTDOOR DISPLAYS.	LLK	
3	27 OCT 00	CHANGED POWER CONN. DWG# FROM B-98318 TO CHART 1	LMH	
4	27 AUG 01	REVISED COMPUTER SPEC BOX, ADDED DRUGS: N-3000-1G, AND AF-3069	DJM	
5	06 MAR 02	ADDED AF-3068 AND AF-3090 TO CHART 1	TJN	
6	23 FEB 07	UPDATED CHART 1 REFERENCES REMOVED DB25F COM PORT REFERENCES.	MLG	

**COMPUTER SPECS**  
 - REFER TO VENUS 1500 MANUAL FOR CURRENT SPECS.

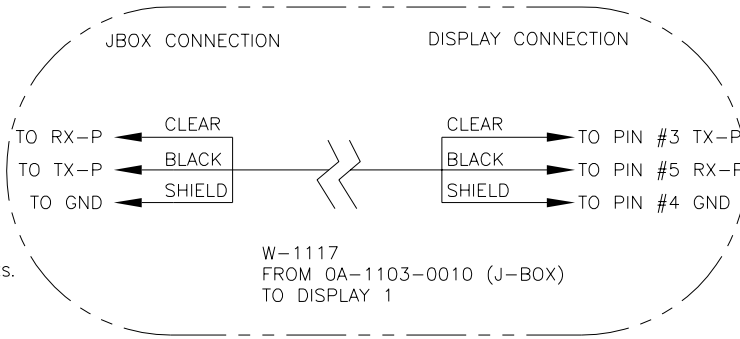
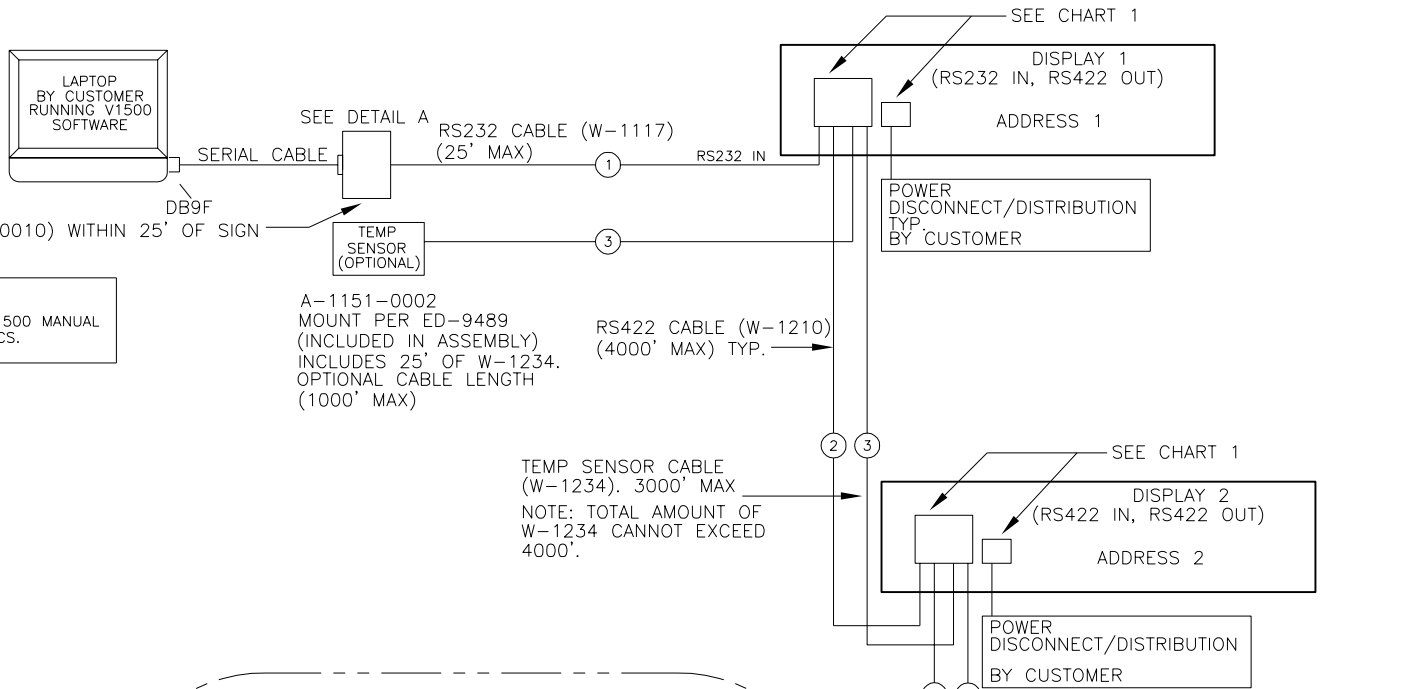

W-1117  
 FROM 0A-1103-0010 (J-BOX)  
 TO DISPLAY 1

DETAIL A

**NOTES**

- 2 CONDUCTOR, 18 AWG, STRANDED SHIELDED CABLE, DAK. P.N. (W-1117). BELDON P.N. (8760) OR EQUIV.
- 6 CONDUCTOR, 22 AWG, STRANDED SHIELDED CABLE, DAK. P.N. (W-1210). BELDON P.N. (9942) OR EQUIV. IN CONDUIT WHERE REQUIRED, FIELD SIGNAL TERMINATIONS TO BE PHOENIX TERMINAL BLOCKS. REFER TO DISPLAY MANUAL FOR TERMINATION. FIELD CABLES ARE "FLIPPED" FROM ONE END TO THE OTHER.
- 4 CONDUCTOR, 22 AWG, STRANDED SHIELDED CABLE, DAK. P.N. (W-1234). MANHATTAN P.N. (M4473) OR EQUIV. IN CONDUIT WHERE REQUIRED, FIELD SIGNAL TERMINATIONS TO BE PHOENIX TERMINAL BLOCKS. REFER TO DISPLAY MANUAL FOR TERMINATION.
- RS/232 CONTROL EQUIPMENT KIT INCLUDES:  
 W-1249.....SERIAL CABLE  
 A-1103-0010.....J-BOX
- INPUT TO J-BOX IS RS232, OUTPUT IS RS232.
- ALL SIGNAL CABLES BY CUSTOMER. LABOR TO PULL CABLES BY CUSTOMER.
- ALL POWER WIRES BY CUSTOMER. LABOR TO PULL WIRES BY CUSTOMER.
- ALL WIRING TO MEET NEC AND LOCAL ELECTRICAL CODES.  
 DISPLAYS MUST BE GROUNDED PER ARTICLE 250 AND 600 OF THE NATIONAL ELECTRICAL CODE.

CHART 1

DISPLAY TYPE	POWER CONN. DWG.#	SIGNAL CONN. DWG.#	POWER SPEC. DWG.#
AF-3020	A-140262	A-88427	A-154944
X-1000	A-140262	A-88427	A-154944

PROJ: OUTDOOR LED PRODUCT LINE  
 TITLE: SYSTEM RISER DIAGRAM, RS232  
 DES. BY: CIVERSEN  
 DRAWN BY: CIVERSEN  
 DATE: 28 AUG 97

REVISION 06  
 SCALE: NONE  
 1137-R01A-96058

THE CONCEPTS EXPRESSED AND DETAILS SHOWN ON THIS DRAWING ARE CONFIDENTIAL AND PROPRIETARY. DO NOT REPRODUCE BY ANY MEANS, INCLUDING ELECTRONICALLY WITHOUT THE EXPRESS WRITTEN CONSENT OF DAKTRONICS, INC. COPYRIGHT 2007 DAKTRONICS, INC.

DAKTRONICS, INC. BROOKINGS, SD 57006

REV.	DATE	DESCRIPTION	BY	APPR.
5	06MAR02	ADDED AF-3080 AND AF-3090 TO CHART 1	TJN	
6	26 MAR 04	REPLACED A-1127-0256 WITH 0A-1127-0256 (INCLUDES SURGE PROTECTION)	SAI	DJM
7	23 FEB 07	UPDATED CHART 1. REMOVED DB9F COM PORT REFERENCE & A-1127-0256 SERIAL CONVERTER REFERENCES AND DETAIL A.	MLG	

**COMPUTER SPECS**  
- REFER TO VENUS 1500 MANUAL FOR CURRENT SPECS.

1	20JAN99	REVISED FIBER CABLE LENGTH FROM 3000' MAX TO 2000' MAX.	LLK
2	06APR00	REPLACED ENTIRE DRAWING TO INCLUDE ALL OUTDOOR DISPLAYS.	LLK
3	27 OCT 00	ADDED DISTRIBUTION TO DISCONNECT/DISTRIBUTION TO A-140262.	LMH
4	27 AUG 01	REVISED COMPUTER SPEC BOX AND ADDED DRAWINGS, AF-3060-RG, AF-3065 TO CHART 1.	DJM

PROJ: OUTDOOR LED PRODUCT LINE

TITLE: SYSTEM RISER DIAGRAM, FIBER

DES. BY: LKERR DRAWN BY: LKERR DATE: 29DEC98

REVISION 07 APPR. BY: NONE SCALE: NONE 1137-R01A-110559

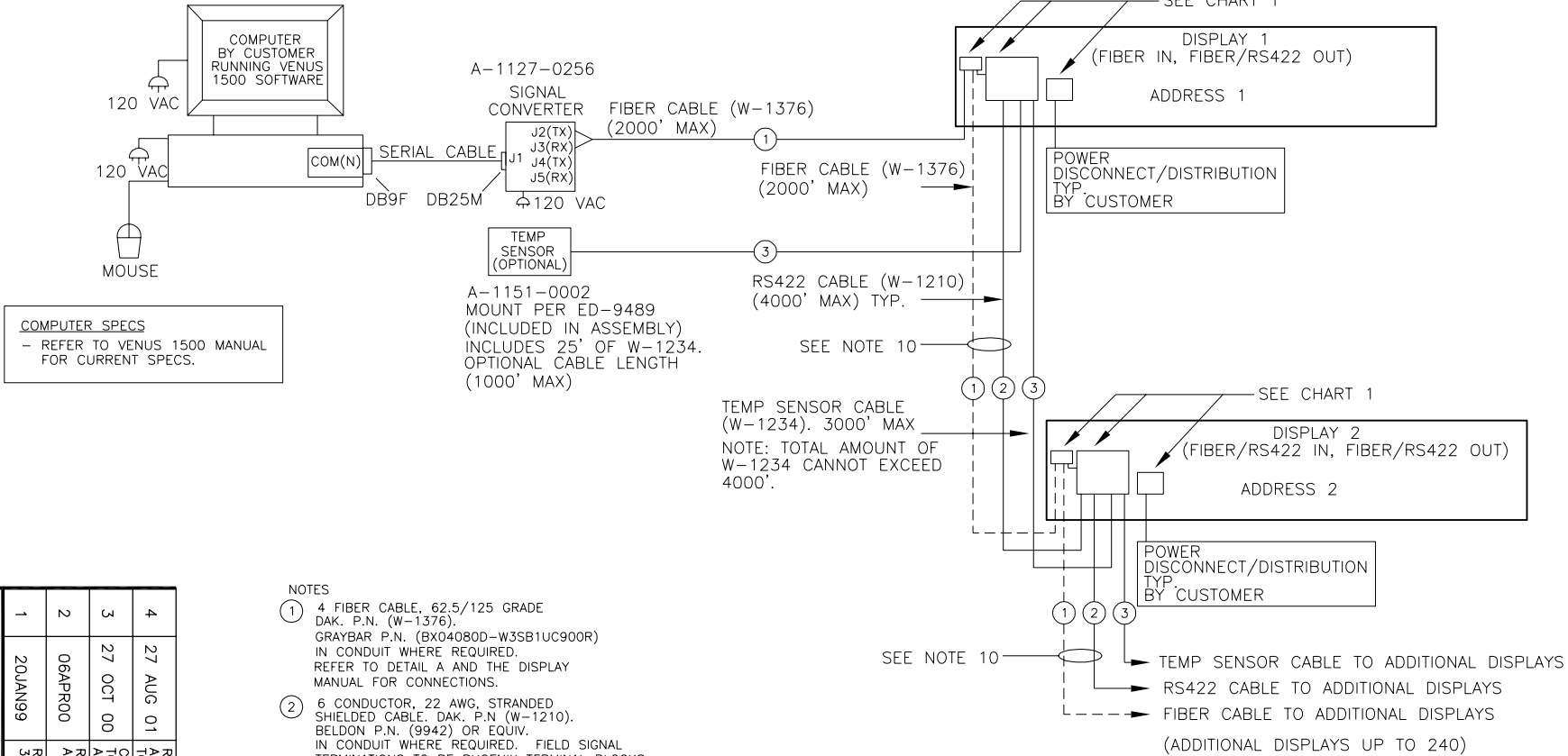

**NOTES**

- ① 4 FIBER CABLE, 62.5/125 GRADE DAK. P.N. (W-1376). GRAYBAR P.N. (BX04080D-W3SB1UC900R) IN CONDUIT WHERE REQUIRED. REFER TO DETAIL A AND THE DISPLAY MANUAL FOR CONNECTIONS.
- ② 6 CONDUCTOR, 22 AWG, STRANDED SHIELDED CABLE, DAK. P.N. (W-1210). BELDON P.N. (9942) OR EQUIV. IN CONDUIT WHERE REQUIRED. FIELD SIGNAL TERMINATIONS TO BE PHOENIX TERMINAL BLOCKS. REFER TO DISPLAY MANUAL FOR TERMINATION. FIELD CABLES ARE "FLIPPED" FROM ONE END TO THE OTHER.
- ③ 4 CONDUCTOR, 22 AWG, STRANDED SHIELDED CABLE, DAK. P.N. (W-1234). MANHATTAN P.N. (M4473) OR EQUIV. IN CONDUIT WHERE REQUIRED. FIELD SIGNAL TERMINATIONS TO BE PHOENIX TERMINAL BLOCKS. REFER TO DISPLAY MANUAL FOR TERMINATION.
4. FIBER CONTROL EQUIPMENT KIT INCLUDES:  
W-1249.....SERIAL CABLE  
A-1127-0256.....SIGNAL CONVERTER
5. INPUT TO CONVERTER IS RS232.
6. ALL SIGNAL CABLES BY CUSTOMER. LABOR TO PULL CABLES BY CUSTOMER.
7. ALL POWER WIRES BY CUSTOMER. LABOR TO PULL WIRES BY CUSTOMER.
8. ALL WIRING TO MEET NEC AND LOCAL ELECTRICAL CODES. DISPLAYS MUST BE GROUNDED PER ARTICLE 250 AND 600 OF THE NATIONAL ELECTRICAL CODE.
9. DISPLAY OUTPUTS CAN BE EITHER FIBER OR RS422.

**DETAIL: A**

COMPUTER	SIGNAL CONVERTER	FIELD CABLE	FIBER BOARD	DISPLAY
	PIN		PIN	
	J2(TX)		J5(RX)	
	J3(RX)		J4(TX)	

CHART 1

DISPLAY TYPE	POWER CONN. DWG.#	SIGNAL CONN. DWG.#	POWER SPEC. DWG.#
AF-3020	A-140262	A-88427	A-154944
X-1000	A-140262	A-88427	A-154944

DETAIL: A

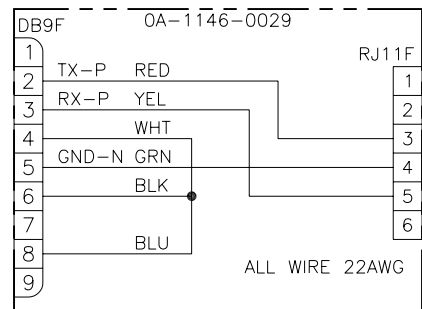
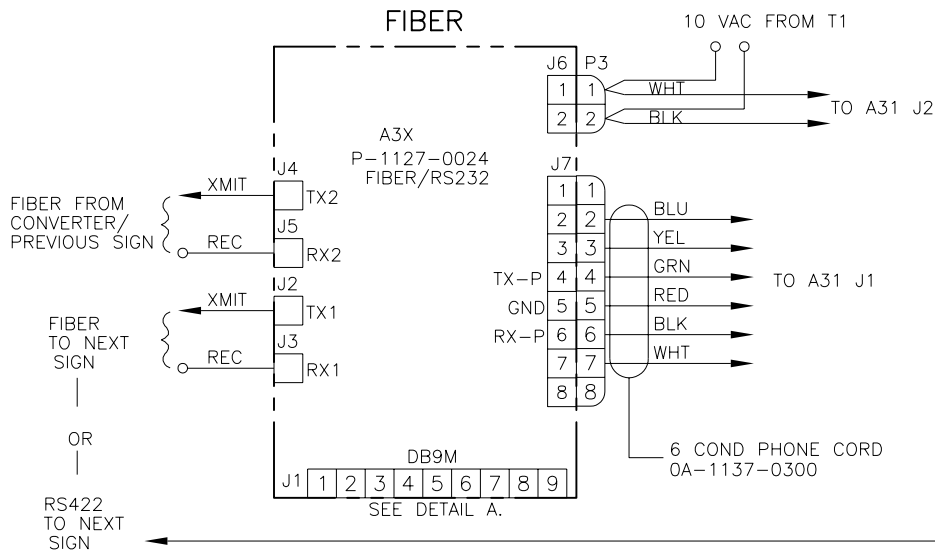

IF FIBER CARD IS BELOW REVISION 10, PC ADAPTOR(OA-1146-0029) IS REQUIRED TO CONNECT RJ11 CABLE FROM A31 J1 TO J1 OF FIBER CARD.

SEE NOTE 3 AND 4

COM1 RS422 OUT (FROM CONTROLLER)

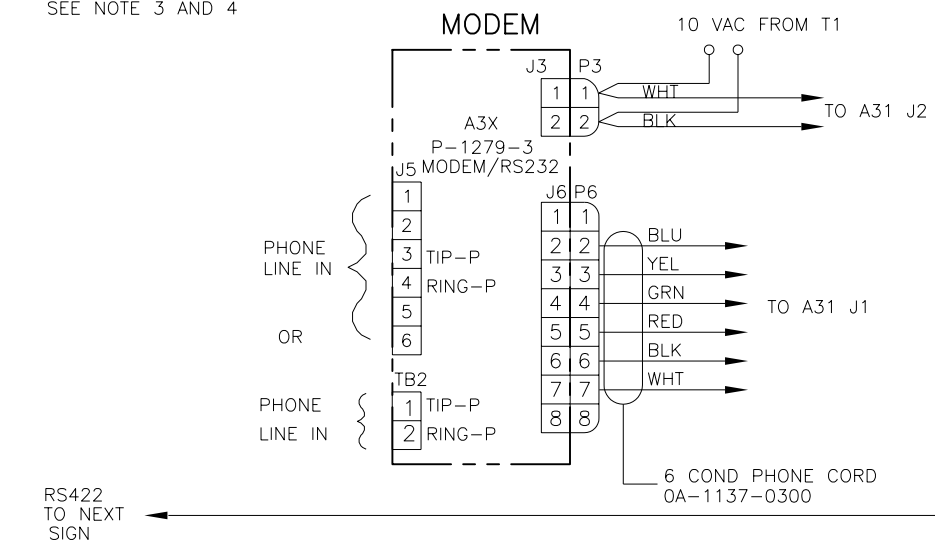

SEE NOTE 3

RS422 SURGE PROTECTOR

P-1146-0031

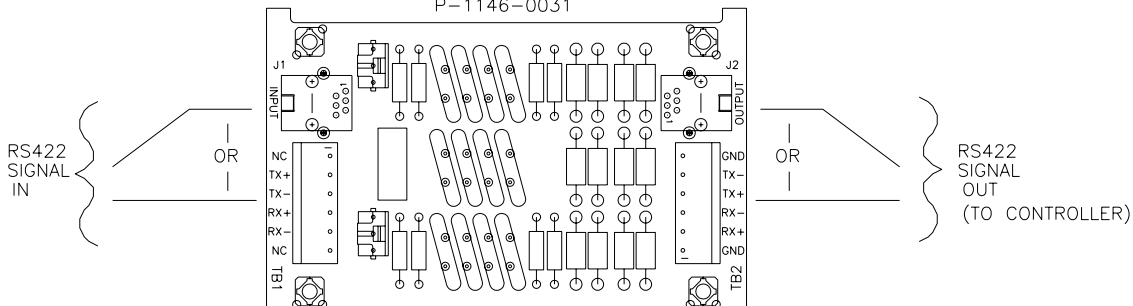

NOTES

- 1) ALL WIRE IS 18 AWG UNLESS OTHERWISE NOTED.
- 2) REFER TO DISPLAY SCHEMATICS FOR COMPLETE SIGN WIRING.
- 3) SURGE PROTECTOR AND MODEM CARDS MUST BE CONNECTED TO THE SIGN'S CHASSIS IN ORDER TO BE EFFECTIVE. THE MOUNTING HOLES (GROUND PADS) OR PIN 1 & 6 OF TB2 ARE USED FOR THIS GROUND CONNECTION.
- 4) AF-3010. TERMINATE TO TB42 PINS 3 (RED) & 4 (GRN).

05	27SEP06	REPLACED P-1146-3 MODEM WITH P-1279-3 REMOVED TELECOM CONNECTOR AND SURGE. REPLACED A-1137-160 WITH A-1137-300.	MLG	
04	09SEPT03	ADDED DETAIL A. J7 WAS ADDED ON REVISION 10 OF FIBER CARD. PC ADAPTOR IS NO LONGER REQUIRED FOR CONNECTION TO CONTROLLER.	DJM	
03	27FEB02	ADDED TELE. SURGE PROTECTOR	JHH	
02	12NOV01	ADDED SURGE PROTECTOR DETAIL	LLK	
01	13MAR00	REMOVED A31 LAYOUT	LLK	
REV.	DATE	DESCRIPTION	BY	APPR.

THE CONCEPTS EXPRESSED AND DETAILS SHOWN ON THIS DRAWING ARE CONFIDENTIAL AND PROPRIETARY. DO NOT REPRODUCE BY ANY MEANS, INCLUDING ELECTRONICALLY WITHOUT THE EXPRESSED WRITTEN CONSENT OF DAKTRONICS, INC. COPYRIGHT 2003 DAKTRONICS, INC.

DAKTRONICS, INC. BROOKINGS, SD 57006

PROJ: \_\_\_\_\_

TITLE: SCHEM; FIBER, MODEM, RS422 SURGE PROTECTOR INPUT

DES. BY: \_\_\_\_\_ DRAWN BY: LKERR DATE: 14DEC99

REVISION 05 APPR. BY: \_\_\_\_\_ SCALE: \_\_\_\_\_

1146-R03A-125900



REV.	DATE	DESCRIPTION	BY	APPR.
14FEB03	07MAY02	CHANGED CLIP ANGLE LAYOUT TO MATCH RIVET HOLE LOCATION OF BKSHIT. ADDED NOTES TO CLARIFY DIMENSIONS FOR THE CLIPS.	MDM	
11AUG00	27JUL00	CHANGED THE LOCATION OF THE CLIP ANGLES.	MDM	
06APR00		ADDED NOTE ABOUT CLIP ANGLES.	MDD	

PROJ: 34mm MATRIX DISPLAY  
 TITLE: MTG CLIP ANGLES, AF-3\*6\*-40/48X\*\*-34MM  
 DES. BY: MDENNIS  
 DRAWN BY: MDENNIS  
 DATE: 20MAR00

REVISION 05  
 APPR. BY: 1213-E10A-128799  
 SCALE: 1=30

DAKTRONICS, INC. BROOKINGS, SD 57006



NOTES:

1. ALL DIMENSIONS ARE IN INCHES. QUANTITY OF CLIP ANGLES WILL VARY DEPENDING ON SIZE OF DISPLAY.
2. PLACE CLIPS 42.56" TO THE RIGHT OF THE 38.99 DIMENSION UNTIL THE CLIPS ARE A MAXIMUM OF 42.56" AWAY FROM EACH OTHER. NOTE IN SOME CASES THE CLIPS MAY ONLY BE ABOUT 15" APART ON THE LEFT END OF THE CABINET. (REAR VIEW)
3. REMOVE RIVET WHEN IT IS IN THE PATH OF THE HOLE NEEDED FOR THE 1/2-13 BOLT.

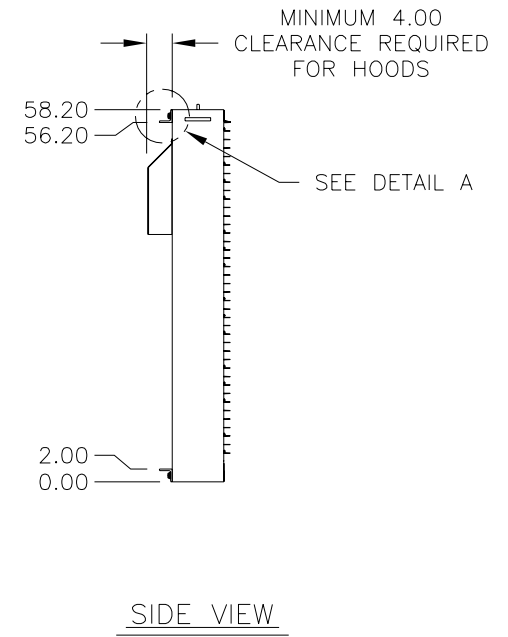
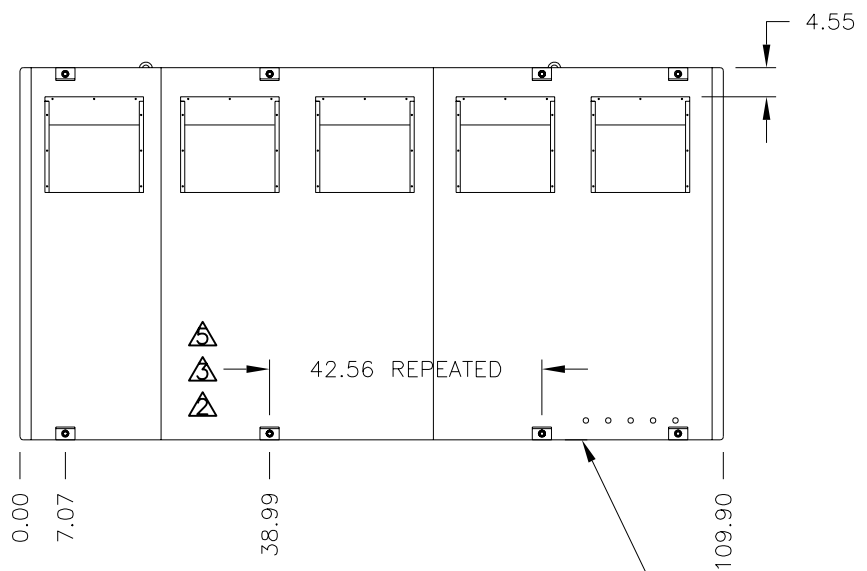
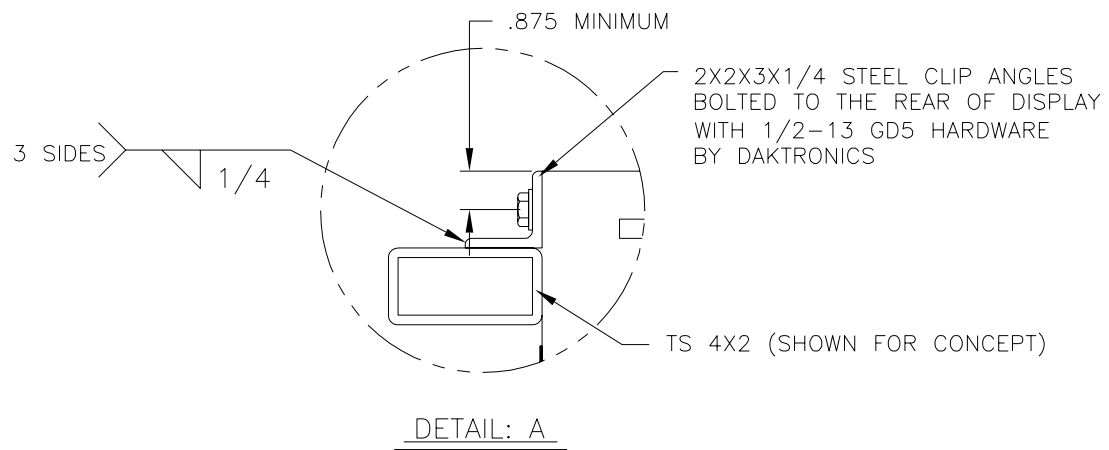

6	14FEB03	CHANGED CLIP ANGLE LAYOUT TO MATCH RIVET HOLE LOCATION ON BKSHIT.	MDM	
5	07MAY02	ADDED NOTES TO CLARIFY DIMENSIONS FOR THE CLIPS.	MDM	
4	11AUG00	CHANGED LOCATION OF MOUNTING CLIPS.	MDM	
3	24JUL00	CHANGED LOCATION OF MOUNTING CLIPS ON THE INTER BODY OF CABINET.	MDM	
2	16JUN00	CHANGED LOCATION OF MOUNTING CLIPS FROM THE END OF THE CABINET.	MDM	
1	05APR00	MOVED CLIP ANGLES 21.28"	MDM	
REV.	DATE	DESCRIPTION	BY	APPR.

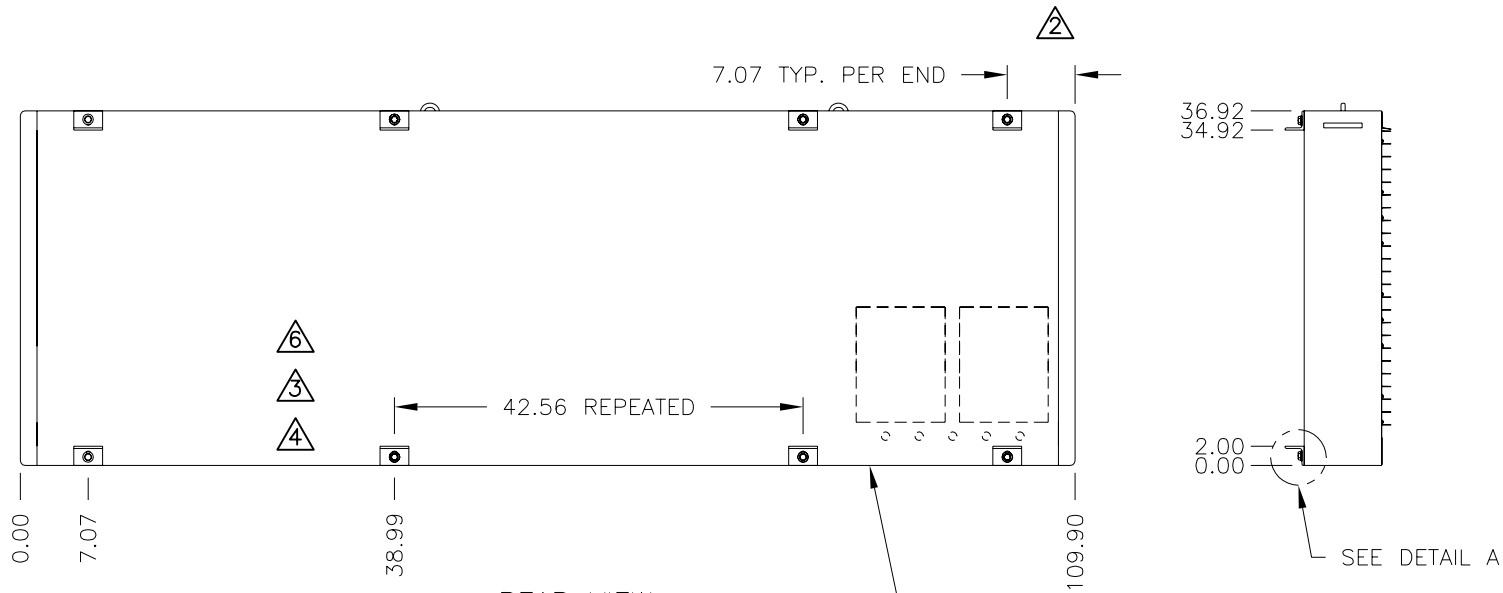

REAR VIEW

(24X80 SHOWN)

SIDE VIEW



NOTES:

1. ALL DIMENSIONS ARE IN INCHES. QUANTITY OF CLIP ANGLES WILL VARY DEPENDING ON SIZE OF DISPLAY.
2. PLACE CLIPS 42.56" TO THE RIGHT OF THE 38.99 DIMENSION UNTIL THE CLIPS ARE A MAXIMUM OF 42.56" AWAY FROM EACH OTHER. NOTE IN SOME CASES THE CLIPS MAY ONLY BE ABOUT 15" APART ON THE LEFT END OF THE CABINET. (REAR VIEW)
3. REMOVE RIVET WHEN IT IS IN THE PATH OF THE HOLE NEEDED FOR THE 1/2-13 BOLT.



LOCATION OF CLIP ANGLES NOT TO INTERFERE WITH FILTER MOUNTING BRACKETS.

2X2X3X1/4 STEEL ANGLE BOLTED TO REAR OF DISPLAY WITH 1/2-13 GD5 HARDWARE BY DAKTRONICS.

.875 MINIMUM

DETAIL: A

PROJ: 34mm MATRIX DISPLAY  
 TITLE: CLIP ANGLE MOUNTING ; AX-XXXX-8/32XX-34B  
 DES. BY: MMAMWENGA DRAWN BY: MDENNIS DATE: 21MAR00  
 REVISION 06 APPR. BY: SCALE: 1=20 1213-E10A-128801  
 DAKTRONICS, INC. BROOKINGS, SD 57006

# A31 CONTROLLER CARD

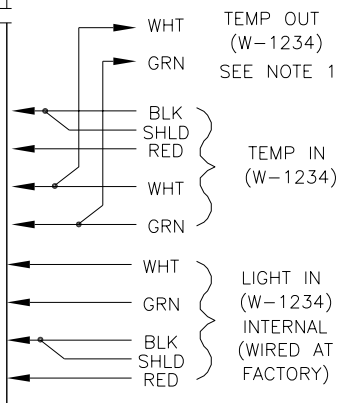
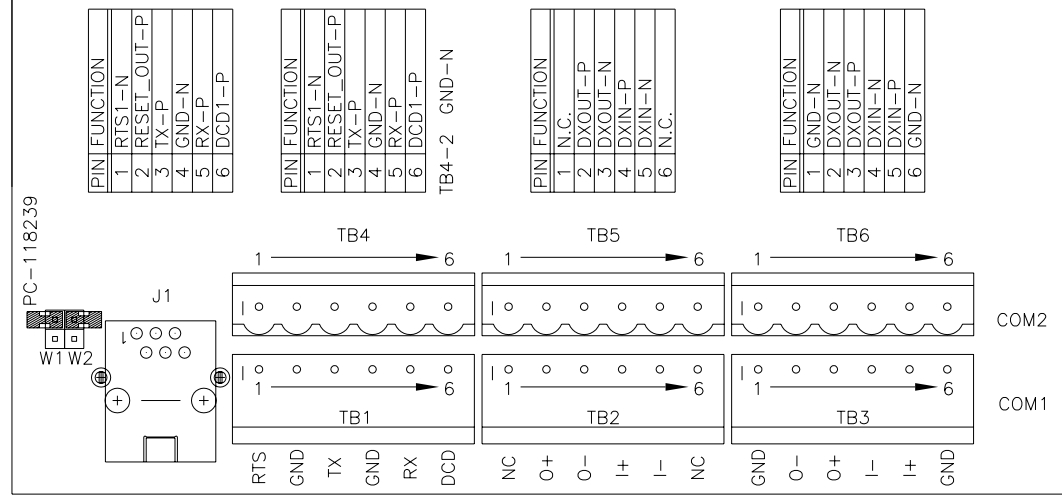

PC-118239

RS232 IN  
J1

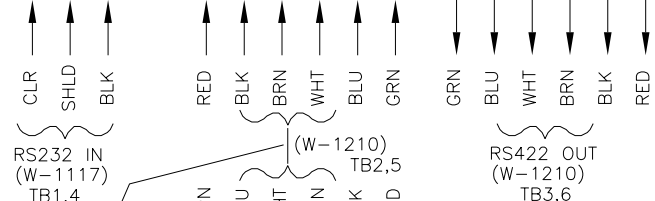

CABLE BETWEEN IS  
PINNED ONE TO ONE

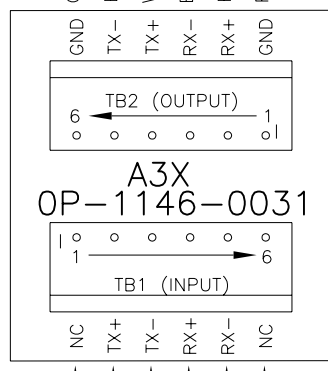

GROUND CONNECTION  
MUST BE MAINTAINED

**NOTES:**

- 1) TO ADDITIONAL DISPLAYS WHEN USING A SINGLE TEMP SENSOR. (NOTE THAT THE RED AND BLK WIRES ARE NOT CONNECTED TO SUBSEQUENT CONTROLLER CARDS)

REV.	DATE	DESCRIPTION	BY	APPR.
02	13DEC01	ADDED WIRE COLORS TO TB2 OF A3X	LLK	LLK
01	13NOV01	ADDED OP-1146-0031	LLK	

<b>DAKTRONICS, INC. BROOKINGS, SD 57006</b>			
PROJ:			
TITLE:	SIGNAL INPUT, OUTDOOR VENUS 1500		
DES. BY:	DRAWN BY: LKERR	DATE: 9MAR00	
REVISION	APPR. BY:	1146-R01A-129110	
	SCALE: NONE		

## 34mm LOUVERED RGB GALAXY DISPLAYS POWER SPECIFICATION CHART

MATRIX SIZE	TOTAL WATTS	120V AMPS	120/240 3, wire		240V AMPS
			LINE 1 AMPS	LINE 2 AMPS	
8X48	363	3.02	NOTE:  120/240 VAC, 3 WIRE PLUS GND. IS NOT AVAILABLE ON THESE DISPLAY SIZES.		1.51
8X64	458	3.82			1.91
8X80	553	4.61			2.31
8X96	649	5.41			2.70
8X112	816	6.80			3.40
8X128	911	7.59			3.80
8X144	1006	8.39			4.19
16X48	649	5.41			2.23
16X64	839	6.99	3.82	3.18	3.50
16X80	1102	9.18	4.41	4.77	4.59
16X96	1292	10.77	4.41	6.36	5.38
16X112	1483	12.36	6.00	6.36	6.18
16X128	1674	13.95	7.59	6.36	6.97
16X144	1936	16.13	8.19	7.95	8.07
24X48	1006	8.39	3.62	4.77	4.19
24X64	1292	10.77	6.00	4.77	5.38
24X80	1650	13.75	6.60	7.15	6.87
24X96	1936	16.13	8.98	7.15	8.07
24X112	2294	19.11	9.58	9.54	9.56
24X128	2580	21.50	11.96	9.54	10.75
24X144	2937	24.48	12.56	11.92	12.24
32X48	1292	10.77	4.41	6.36	5.38
32X64	1674	13.95	7.59	6.36	6.97
32X80	2127	17.72	8.19	9.54	8.86
32X96	2508	20.90	8.19	12.71	10.45
32X112	2961	24.68	11.96	12.71	12.34
32X128	3343	27.85	15.14	12.71	13.93
32X144	3795	31.63	15.74	15.89	15.81
40X48	1650	13.75	5.80	7.95	6.87
40X64	2198	18.32	10.37	7.95	9.16
40X80	2747	22.89	10.97	11.92	11.44
40X96	3295	27.46	13.95	13.51	13.73
40X112	3843	32.03	16.13	15.89	16.01
40X128	4391	36.60	20.70	15.89	18.30
40X144	4940	41.16	21.30	15.89	20.58
48X48	1936	16.13	6.60	9.54	8.07
48X64	2580	21.50	11.96	9.54	10.75
48X80	3223	26.86	12.56	14.30	13.43
48X96	3867	32.22	13.15	19.07	16.11
48X112	4511	37.59	18.52	19.07	18.79
48X128	5154	42.95	23.88	19.07	21.48
48X144	5798	48.32	24.48	23.84	24.16

THE ABOVE DISPLAY SIZES CAN BE POWERED BY EITHER 120VAC (2 WIRE + GND), 120/240 (3 WIRE + GND) OR 240VAC (2 WIRE + GND) SERVICES (EXCEPT WHERE NOTED). 240VAC (2 WIRE + GND) SERVICES (TYPICAL OVERSEAS), REQUIRE BREAKERS DESIGNED FOR SUCH USE. \* WHERE 2 WIRE + GND SYSTEMS ARE USED, LINE 1 AND LINE 2 TERMINALS NEED TO BE CONNECTED BY FIELD INSTALLED JUMPER. JUMPER SIZED PER NEC.

DAKTRONICS, INC. BROOKINGS, SD 57006			
PROJ: 34MM			
TITLE: POWER SPECS, 8X48-48X144 DISPLAY, RGB			
DES. BY: LKERR		DRAWN BY: JSPAHR	
DATE: 10 MAY 01			
REVISION	APPR. BY:		
	SCALE:	1=1	1241-R10A-148571

REV.	DATE	DESCRIPTION	BY	APPR.

REV.	01
DATE	17SEP01
DESCRIPTION	UPDATED POWER TERM BOX AND MTG PLATE
BY	BGB
APPR.	

PROJ.	DAKTRONICS, INC. BROOKINGS, SD 57006	
TITLE	GALAXY, LOUVERED V1500 RGB 34MM	
DES. BY:	MAMMENGA	DRAWN BY: MAMMENGA
APPR. BY:		DATE: 31MAY01
REVISION	1241-E10A-148630	
SCALE:	1=25	

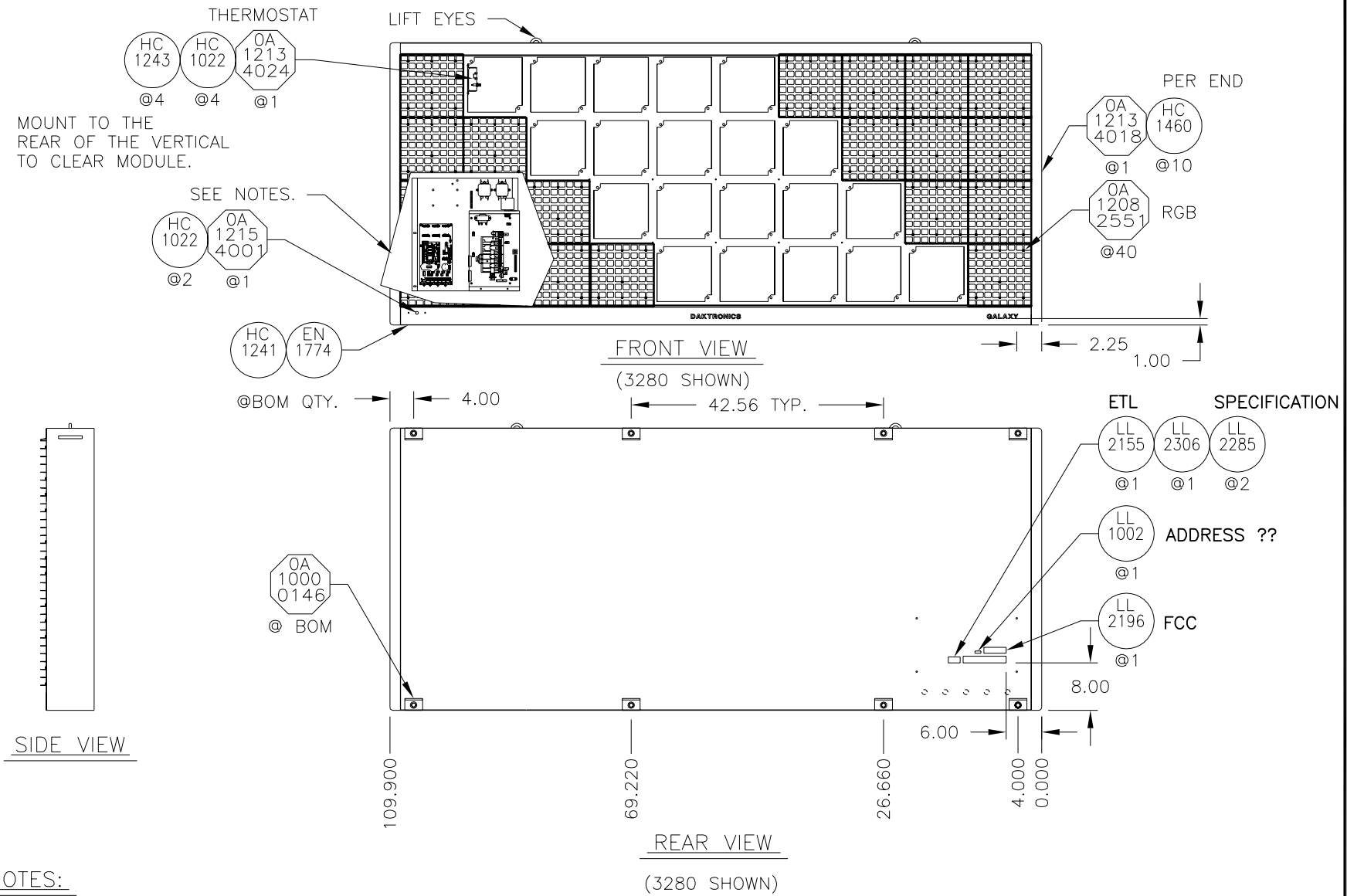

1. REFER TO BOM FOR SHELL AND HARNESS PACKETS.
2. USE W-1412 FOR HORIZONTAL SIGNAL CONNECTION.
3. USE OA-1213-4023 FOR LABELING DISPLAY.
4. REFER TO COMPONENT LAYOUT DIAGRAM FOR INTERNAL COMPONENTS.
5. REFER TO ER-12114 FOR TEST PROCEDURE.
6. FOLLOW ER-10711 FOR ASSEMBLY AND A CHECKLIST.
7. SEE DWG-00156086 FOR DETAIL OF CONTROLLER AND POWER TERM BOX.
8. CENTER "DAKTRONICS" LABEL ON BOTTOM SHROUD.
9. PUT THE ADDRESS NUMBER ON THE LL-1002.

REV.	DATE	DESCRIPTION	BY	APPR.
------	------	-------------	----	-------

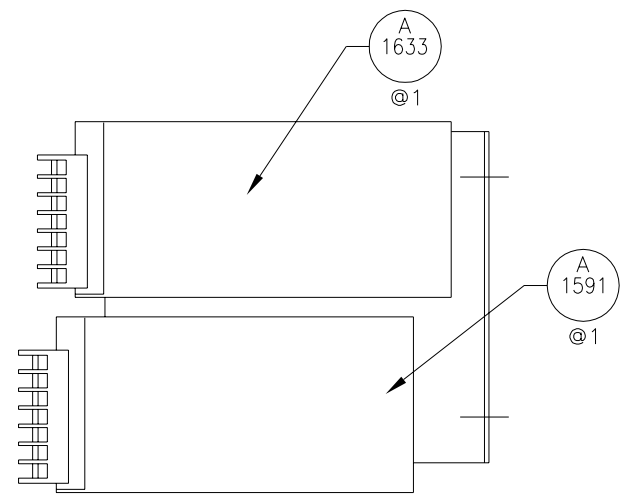
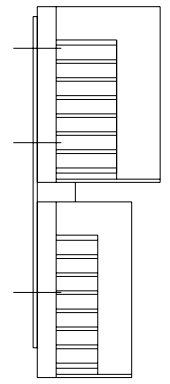
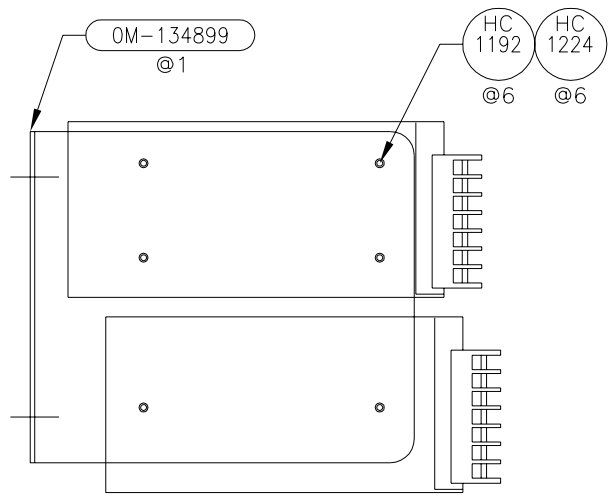
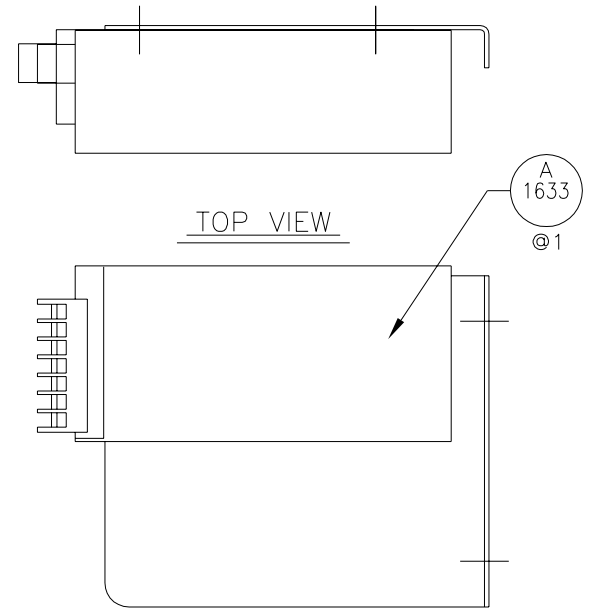
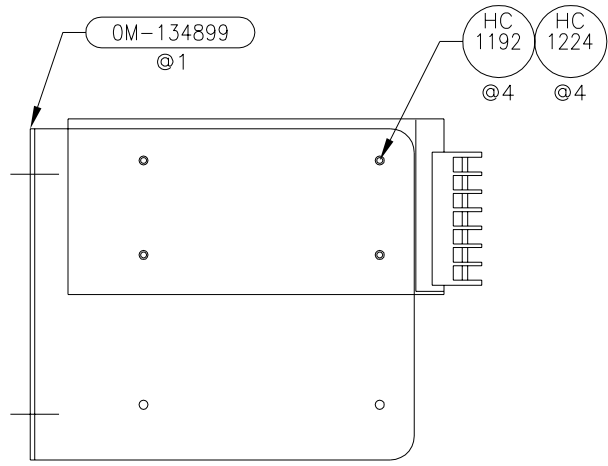

REAR VIEW

LEFT SIDE

FRONT VIEW

NOTES:

THIS IS ONE ASSEMBLY. IT CONSISTS OF 2 PLATES. ONE PLATE HAS 2 P.S. THE OTHER HAS 1 P.S. THE 2 PLATES CAN MOUNT IN DIFFERENT LOCATIONS IN THE CABINET. THE POWER SUPPLIES ARE CONNECTED TOGETHER BY A HARNESS.

THE CONCEPTS EXPRESSED AND DETAILS SHOWN ON THIS DRAWING ARE CONFIDENTIAL AND PROPRIETARY. DO NOT REPRODUCE BY ANY MEANS, INCLUDING ELECTRONICALLY WITHOUT THE EXPRESSED WRITTEN CONSENT OF DAKTRONICS, INC. COPYRIGHT 2002 DAKTRONICS, INC.

DAKTRONICS, INC. BROOKINGS, SD 57006

PROJ: GALAXY, LOUVERED V1500 RGB 34MM

TITLE: ASSY, POWER SUPPLY A-1633 @2, A-1591

DES. BY: MMAMMENGA DRAWN BY: MMAMMENGA DATE: 25JUL02

REVISION	APPR. BY:	DATE:
SCALE: 1=4	1241-E10A-148636	

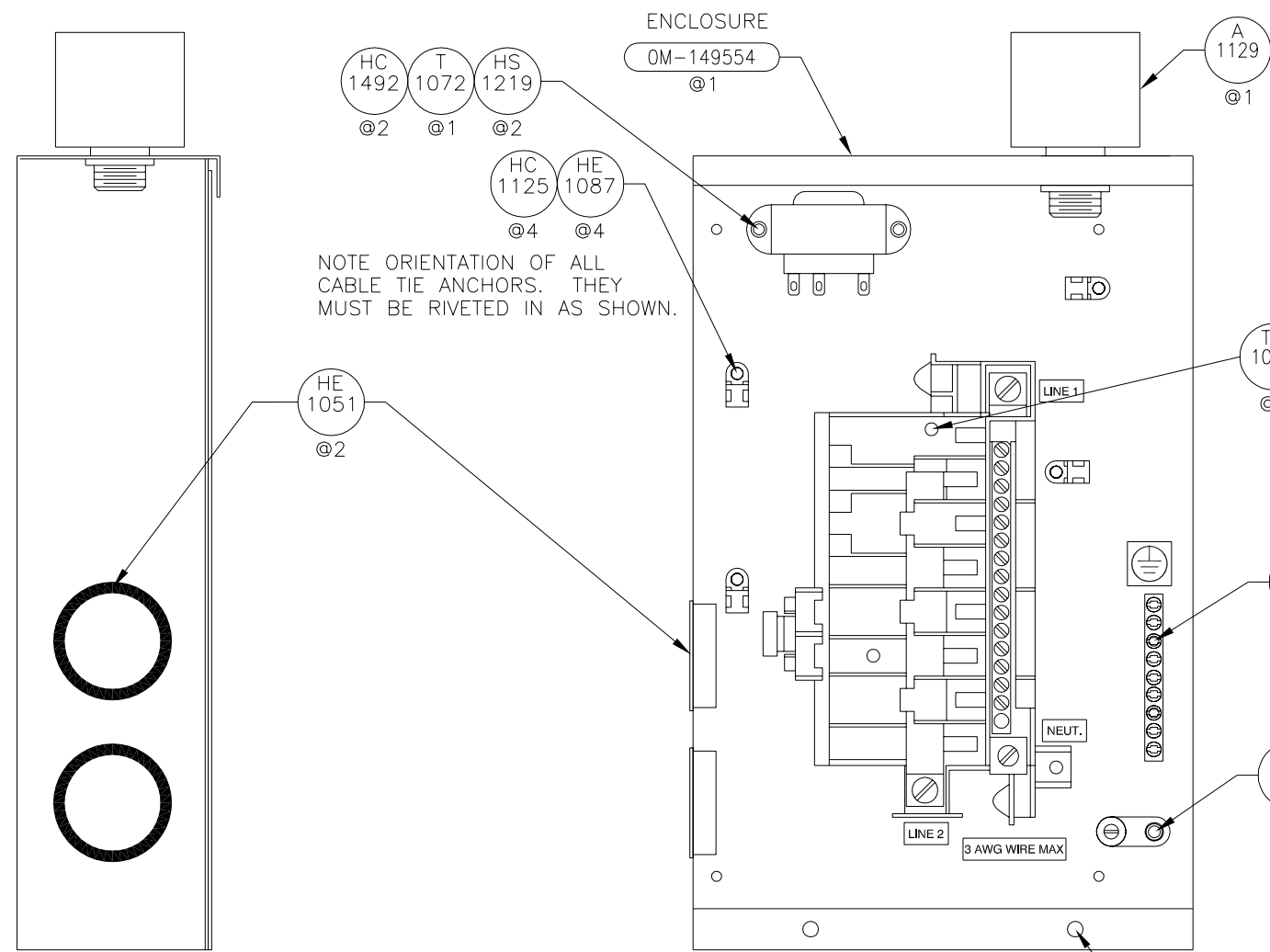

LEFT SIDE

FRONT VIEW  
(ENCLOSURE SHOWN WITH COVER REMOVED FOR CLARITY)

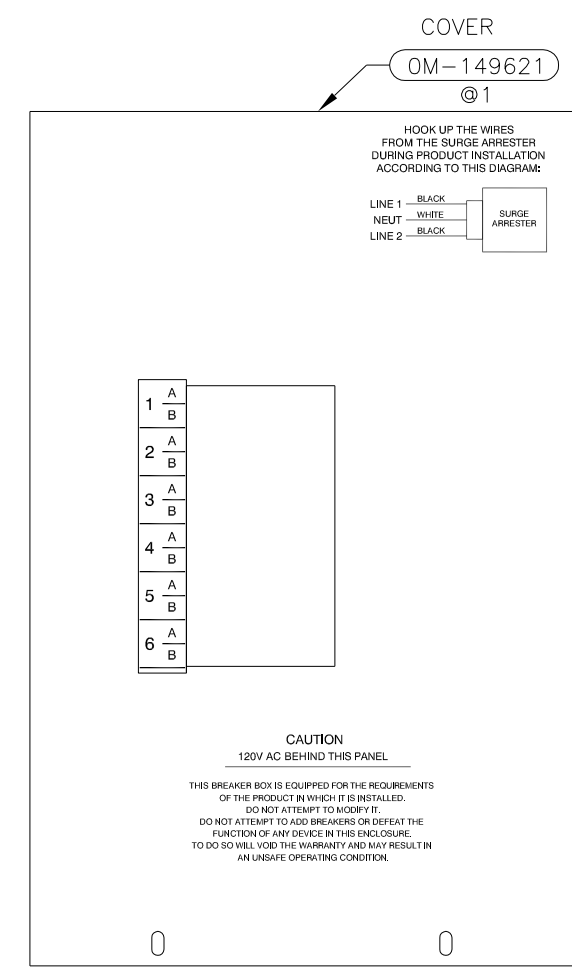

FRONT VIEW  
(COVER)

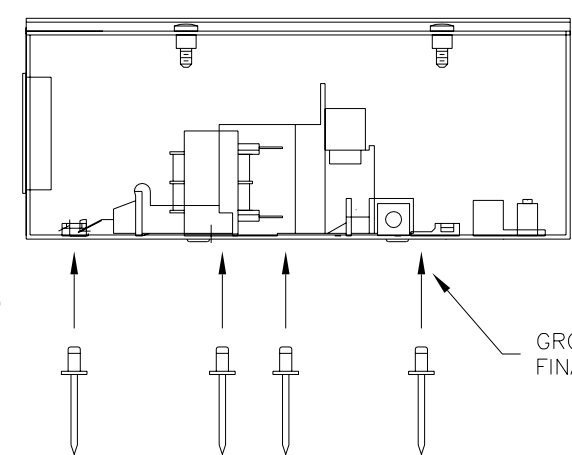

BOTTOM VIEW

- NOTES
1. USE LL-2429 FOR LABELS SHOWN.
  2. ENSURE LABELS ARE LOCATED AS SHOWN.

REV.	DATE	DESCRIPTION	BY	APPR.
03	27AUG2002	CHANGED HC-1395 TO HC-1492 @2 AND CHANGED COVER ATTACH HOLE SIZE TO ACCOMMODATE HARDWARE @2	EJY	
02	29 JUN 01	REMOVED LL-1064. ADDED NOTES REGARDING LABEL PLACEMENT.	JAA	MDM
01	27JUN01	CHANGED THE PLACEMENT OF 2.00" HOLES. CHANGED FROM HE-1051 @3 TO @2. CHANGE LOCATION OF T-1072. MADE 1/2" WIDER.	MDM	

DAKTRONICS, INC. BROOKINGS, SD 57006	
PROJ:	GALAXY, LOUVERED V1500 RGB 34MM
TITLE:	ENTRANCE BOX 8/16
DES. BY:	MMAMMENGA
DRAWN BY:	MMAMMENGA
DATE:	31MAY01
REVISION	APPR. BY:
	SCALE: 1=3
1241-E10B-149160	

REV. DATE DESCRIPTION BY APPR.

DENOTES POWER SUPPLY LOCATION.  
(I.E. PS105 IS LOCATED BEHIND A105.)

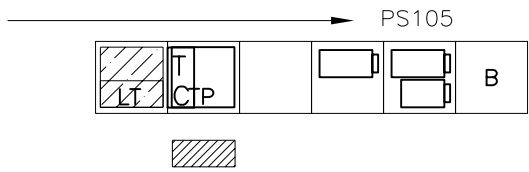

FRONT VIEW

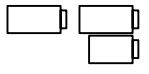

POWER SUPPLIES  
0A-1241-4001

PS ASSY, 2, A-1633; 1, A-1591 RGB

B

FAN  
0A-1213-4010  
B-1019 W/HARDWARE

T  
C

THERMOSTAT  
0A-1213-4024  
ENCLOSURE; THERMOSTAT 85-70-9L  
MOUNTED ON VERTICAL.



POWER TERMINATION BOX  
0A-1241-4004  
ASSY; POWER TERM BOX 2/4 RGB, 120V

LT

LIGHT DETECTOR  
0A-1215-4001  
ASSY; LIGHT DETECTOR-34MM



CONTROLLER BOARD  
0A-1146-0067  
CONTROLLER BOARD



FILTER  
EN-1774  
FILTER W/ WEATHERSTRIP

NOTES:

1. 10.64" FOR MODULE SIZE

DAKTRONICS, INC. BROOKINGS, SD 57006  
 PROJ: GALAXY, LOUVERED V1500 RGB 34mm  
 TITLE: COMP. LAYOUT DIAGRAM; AF-3065-848-34-RGB  
 DES. BY: MMAMMENGA DRAWN BY: JMAMMENGA DATE: 23MAY01  
 REVISION APPR. BY: SCALE: NONE  
 1241-E10A-149301



REV. DATE DESCRIPTION BY APPR.

DENOTES POWER SUPPLY LOCATION.  
(I.E. PS105 IS LOCATED BEHIND A105.)

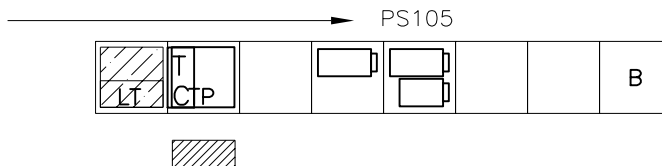

FRONT VIEW

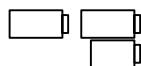

POWER SUPPLIES  
0A-1241-4001

PS ASSY, 2, A-1633; 1, A-1591 RGB

B

FAN

0A-1213-4010  
B-1019 W/HARDWARE

TC

THERMOSTAT

0A-1213-4024  
ENCLOSURE; THERMOSTAT 85-70-9L  
MOUNTED ON VERTICAL.



POWER TERMINATION BOX  
0A-1241-4004  
ASSY; POWER TERM BOX 120V-\*L



LIGHT DETECTOR  
0A-1215-4001  
ASSY; LIGHT DETECTOR-34MM



CONTROLLER BOARD  
0A-1146-0067  
CONTROLLER BOARD



FILTER  
EN-1774  
FILTER W/ WEATHERSTRIP

NOTES:

1. 10.64" FOR MODULE SIZE

DAKTRONICS, INC. BROOKINGS, SD 57006  
 PROJ: GALAXY, LOUVERED V1500 RGB 34MM  
 TITLE: COMP. LAYOUT DIAGRAM; AF-3065-864-34-RGB  
 DES. BY: MMAMMENGA DRAWN BY: JMAMMENGA DATE: 23MAY01  
 REVISION APPR. BY: SCALE: NONE  
 1241-E10A-149309

REV.  
DATE  
DESCRIPTION  
BY  
APPR.

DENOTES POWER SUPPLY LOCATION.  
(I.E. PS105 IS LOCATED BEHIND A105.)

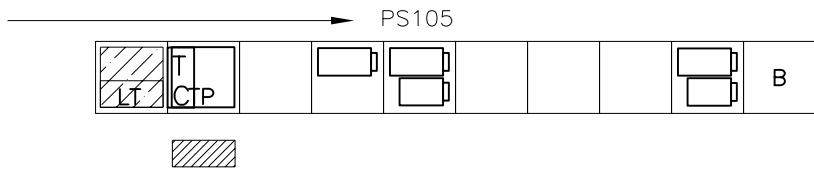

FRONT VIEW

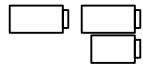

POWER SUPPLIES  
0A-1241-4001

PS ASSY, 2, A-1633; 1, A-1591 RGB

B

FAN

0A-1213-4010  
B-1019 W/HARDWARE

T  
C

THERMOSTAT

0A-1213-4024  
ENCLOSURE; THERMOSTAT 85-70-9L  
MOUNTED ON VERTICAL.



POWER TERMINATION BOX  
0A-1241-4004  
ASSY; POWER TERM BOX 120V-\*L



LIGHT DETECTOR  
0A-1215-4001  
ASSY; LIGHT DETECTOR-34MM



CONTROLLER BOARD  
0A-1146-0067  
CONTROLLER BOARD



FILTER  
EN-1774  
FILTER W/ WEATHERSTRIP



POWER SUPPLIES  
0A-1213-4034  
PS ASSY, (1, A-1591, 1, A-1633)

NOTES:

1. 10.64" FOR MODULE SIZE

DAKTRONICS, INC. BROOKINGS, SD 57006  
 PROJ: GALAXY, LOUVERED V1500 RGB 34MM  
 TITLE: COMP. LAYOUT DIAGRAM; AF-3065-880-34-RGB  
 DES. BY: MMAMMENGA DRAWN BY: JMMAMMENGA DATE: 23MAY01  
 REVISION  
 APPR. BY: NONE SCALE: NONE  
 1241-E10A-149310

REV.  
DATE  
DESCRIPTION  
BY  
APPR.

DENOTES POWER SUPPLY LOCATION.  
(I.E. PS105 IS LOCATED BEHIND A105.)

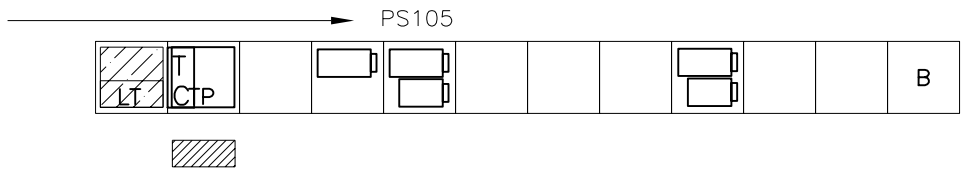

FRONT VIEW

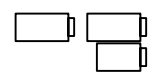

POWER SUPPLIES  
0A-1241-4001

PS ASSY, 2, A-1633; 1, A-1591 RGB

B

FAN  
0A-1213-4010  
B-1019 W/HARDWARE

T  
C

THERMOSTAT  
0A-1213-4024  
ENCLOSURE; THERMOSTAT 85-70-9L  
MOUNTED ON VERTICAL.



POWER TERMINATION BOX  
0A-1241-4004  
ASSY; POWER TERM BOX 120V-\*L



LIGHT DETECTOR  
0A-1215-4001  
ASSY; LIGHT DETECTOR-34MM



CONTROLLER BOARD  
0A-1146-0067  
CONTROLLER BOARD



FILTER  
EN-1774  
FILTER W/ WEATHERSTRIP



POWER SUPPLIES  
0A-1213-4034  
PS ASSY, (1, A-1591, 1, A-1633)

NOTES:

1. 10.64" FOR MODULE SIZE

DAKTRONICS, INC. BROOKINGS, SD 57006  
 PROD: GALAXY, LOUVERED V1500 RGB 34MM  
 TITLE: COMP. LAYOUT DIAGRAM; AF-3065-896-34-RGB  
 DES. BY: MMAMMENGA DRAWN BY: JMAMMENGA DATE: 23MAY01  
 REVISION  
 APPR. BY: NONE  
 SCALE: NONE  
 1241-E10A-149311

REV. DATE DESCRIPTION BY APPR.

DENOTES POWER SUPPLY LOCATION.  
(I.E. PS105 IS LOCATED BEHIND A105.)

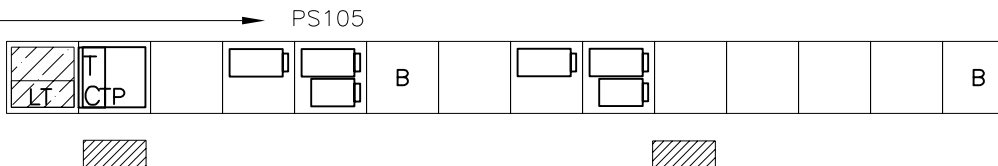

FRONT VIEW

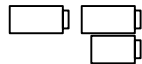

POWER SUPPLIES  
0A-1241-4001

PS ASSY, 2, A-1633; 1, A-1591 RGB

B

FAN

0A-1213-4010  
B-1019 W/HARDWARE

T  
C

THERMOSTAT

0A-1213-4024  
ENCLOSURE; THERMOSTAT 85-70-9L  
MOUNTED ON VERTICAL.



POWER TERMINATION BOX  
0A-1241-4004  
ASSY; POWER TERM BOX 120V-\*L

LT

LIGHT DETECTOR  
0A-1215-4001  
ASSY; LIGHT DETECTOR-34MM



CONTROLLER BOARD  
0A-1146-0067  
CONTROLLER BOARD



FILTER  
EN-1774  
FILTER W/ WEATHERSTRIP

NOTES:

1. 10.64" FOR MODULE SIZE

DAKTRONICS, INC. BROOKINGS, SD 57006  
 PROJ: GALAXY, LOUVERED V1500 RGB 34MM  
 TITLE: COMP. LAYOUT DIAGRAM; AF-3065-8112-34-RGB  
 DES. BY: MMAMMENGA DRAWN BY: JMAMMENGA DATE: 23MAY01  
 REVISION APPR. BY: SCALE: NONE  
 1241-E10A-149312

REV.  
DATE  
DESCRIPTION  
BY  
APPR.

DENOTES POWER SUPPLY LOCATION.  
(I.E. PS105 IS LOCATED BEHIND A105.)

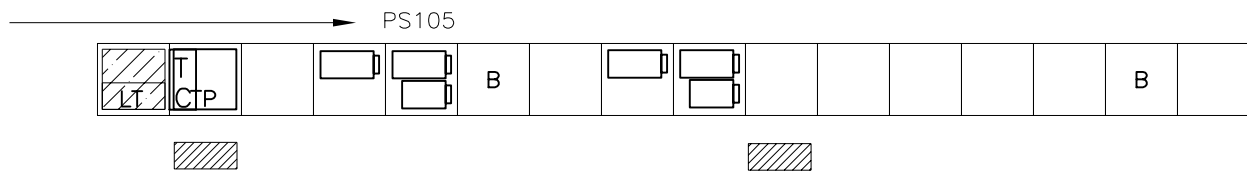

FRONT VIEW

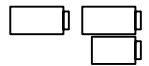

POWER SUPPLIES  
0A-1241-4001  
PS ASSY, 2, A-1633; 1, A-1591 RGB

B

FAN  
0A-1213-4010  
B-1019 W/HARDWARE

T  
C

THERMOSTAT  
0A-1213-4024  
ENCLOSURE; THERMOSTAT 85-70-9L  
MOUNTED ON VERTICAL.



POWER TERMINATION BOX  
0A-1241-4004  
ASSY; POWER TERM BOX 120V-\*L



LIGHT DETECTOR  
0A-1215-4001  
ASSY; LIGHT DETECTOR-34MM



CONTROLLER BOARD  
0A-1146-0067  
CONTROLLER BOARD



FILTER  
EN-1774  
FILTER W/ WEATHERSTRIP

NOTES:

1. 10.64" FOR MODULE SIZE

DAKTRONICS, INC. BROOKINGS, SD 57006  
 PROD: GALAXY, LOUVERED V1500 RGB 34MM  
 TITLE: COMP, LAYOUT DIAGRAM; AF-3065-8128-34-RGB  
 DES. BY: MMAMMENGA DRAWN BY: JMAMMENGA DATE: 23MAY01  
 REVISION  
 APPR. BY: NONE SCALE: NONE  
 1241-E10A-149315

REV.  
DATE  
DESCRIPTION  
BY  
APPR.

DENOTES POWER SUPPLY LOCATION.  
(I.E. PS105 IS LOCATED BEHIND A105.)

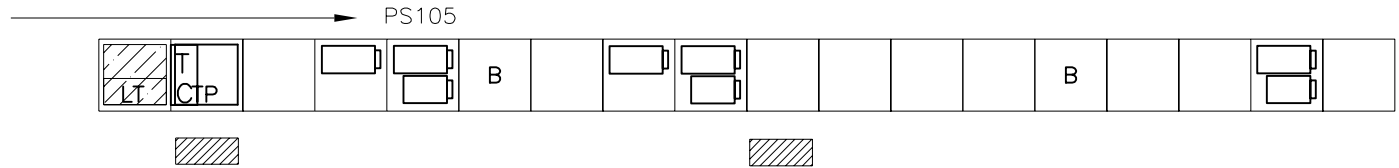

FRONT VIEW

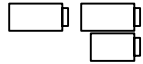

POWER SUPPLIES  
0A-1241-4001  
PS ASSY, 2, A-1633; 1, A-1591 RGB

B

FAN  
0A-1213-4010  
B-1019 W/HARDWARE



THERMOSTAT  
0A-1213-4024  
ENCLOSURE; THERMOSTAT 85-70-9L  
MOUNTED ON VERTICAL.



POWER TERMINATION BOX  
0A-1241-4004  
ASSY; POWER TERM BOX 120V-\*L



LIGHT DETECTOR  
0A-1215-4001  
ASSY; LIGHT DETECTOR-34MM



CONTROLLER BOARD  
0A-1146-0067  
CONTROLLER BOARD



FILTER  
EN-1774  
FILTER W/ WEATHERSTRIP



POWER SUPPLIES  
0A-1213-4034  
PS ASSY, (1, A-1591, 1, A-1633)

NOTES:

1. 10.64" FOR MODULE SIZE

DAKTRONICS, INC. BROOKINGS, SD 57006	
PROJ: GALAXY, LOUVERED V1500 RGB 34MM	REVISION
TITLE: COMP. LAYOUT DIAGRAM: AF-3065-8144-34-RGB	APPR. BY: MAMMENGA
DES. BY: MAMMENGA	SCALE: NONE
DRAWN BY: JAMMENGA	DATE: 23MAY01
1241-E10A-149317	

REV.	01
DATE	06SEP01
DESCRIPTION	CORRECTED POWER SUPPLY LOCATION NOTE
BY	BGB
APPR.	

DENOTES POWER SUPPLY LOCATION.  
(I.E. PS104 IS LOCATED BEHIND A104.)

→ PS104

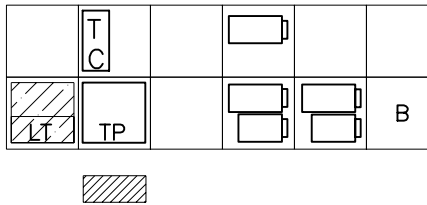

FRONT VIEW

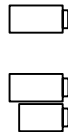

POWER SUPPLIES  
0A-1241-4001

PS ASSY, 2, A-1633; 1, A-1591 RGB



POWER TERMINATION BOX  
0A-1241-4004  
ASSY; POWER TERM BOX 120V-\*L



LIGHT DETECTOR  
0A-1215-4001  
ASSY; LIGHT DETECTOR-34MM



FILTER  
EN-1774  
FILTER W/ WEATHERSTRIP



THERMOSTAT  
0A-1213-4024  
ENCLOSURE; THERMOSTAT 85-70-9L  
MOUNTED ON VERTICAL.



CONTROLLER BOARD  
0A-1146-0067  
CONTROLLER BOARD



POWER SUPPLIES  
0A-1213-4034  
PS ASSY, (1, A-1591, 1, A-1633)

NOTES:

1. 10.64" FOR MODULE SIZE

PROJ:	GALAXY, LOUVERED V1500 RGB 34MM	
TITLE:	COMP. LAYOUT DIAGRAM; AF-3065-1648-34-RGB	
DES. BY:	MAMMENGA	DRAWN BY: JAMMENGA
APPR. BY:		DATE: 23MAY01
SCALE:	NONE	
REVISION	1241-E10A-149321	
DAKTRONICS, INC. BROOKINGS, SD 57006		

REV.	01
DATE	06SEP01
DESCRIPTION	CORRECTED POWER SUPPLY LOCATION NOTE
BY	BGB
APPR.	

DENOTES POWER SUPPLY LOCATION.  
(I.E. PS104 IS LOCATED BEHIND A104.)

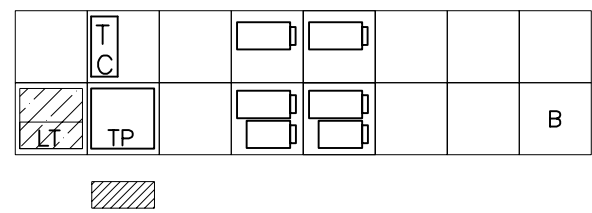
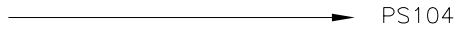

FRONT VIEW

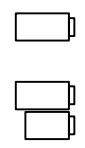

POWER SUPPLIES  
0A-1241-4001

PS ASSY, 2, A-1633; 1, A-1591 RGB

B

FAN

0A-1213-4010  
B-1019 W/HARDWARE

TC

THERMOSTAT

0A-1213-4024  
ENCLOSURE; THERMOSTAT 85-70-9L  
MOUNTED ON VERTICAL.

TP

POWER TERMINATION BOX

0A-1241-4004  
ASSY; POWER TERM BOX 120V-\*L

LT

LIGHT DETECTOR

0A-1215-4001  
ASSY; LIGHT DETECTOR-34MM



CONTROLLER BOARD

0A-1146-0067  
CONTROLLER BOARD



FILTER

EN-1774  
FILTER W/ WEATHERSTRIP

NOTES:

1. 10.64" FOR MODULE SIZE

PROJ:	GALAXY, LOUVERED V1500 RGB 34MM	
TITLE:	COMP. LAYOUT DIAGRAM; AF-3065-1664-34-RGB	
DES. BY:	MMAMMENGA	DRAWN BY: JMAMMENGA
DATE:	23MAY01	
REVISION	APPR. BY:	SCALE: NONE
		1241-E10A-149330

DAKTRONICS, INC. BROOKINGS, SD 57006



REV.	01
DATE	06SEP01
DESCRIPTION	CORRECTED POWER SUPPLY LOCATION NOTE
BY	BGB
APPR.	

DENOTES POWER SUPPLY LOCATION.  
(I.E. PS104 IS LOCATED BEHIND A104.)

PS104

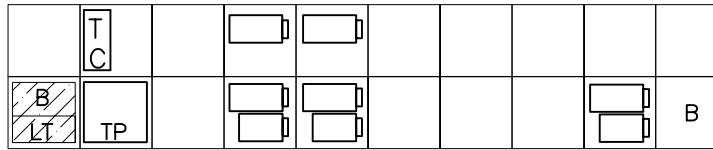

FRONT VIEW



POWER SUPPLIES  
0A-1241-4001

PS ASSY, 2, A-1633; 1, A-1591 RGB



POWER TERMINATION BOX

0A-1241-4004  
ASSY; POWER TERM BOX 120V-\*L



LIGHT DETECTOR

0A-1215-4001  
ASSY; LIGHT DETECTOR-34MM



FILTER  
EN-1774  
FILTER W/ WEATHERSTRIP



THERMOSTAT

0A-1213-4024  
ENCLOSURE; THERMOSTAT 85-70-9L  
MOUNTED ON VERTICAL.



CONTROLLER BOARD  
0A-1146-0067  
CONTROLLER BOARD



POWER SUPPLIES  
0A-1213-4034  
PS ASSY, (1, A-1591, 1, A-1633)

NOTES:

1. 10.64" FOR MODULE SIZE

PROJ:	GALAXY, LOVERED V1500 RGB 34MM	
TITLE:	COMP. LAYOUT DIAGRAM; AF-3065-1680-34-RGB	
DES. BY:	MAMMENGA	DRAWN BY: JMMAMMENGA
APPR. BY:		DATE: 23MAY01
SCALE:	NONE	
REVISION	1241-E10A-149333	
DAKTRONICS, INC. BROOKINGS, SD 57006		

REV.	01
DATE	06SEP01
DESCRIPTION	CORRECTED POWER SUPPLY LOCATION NOTE
BY	BGB
APPR.	

DENOTES POWER SUPPLY LOCATION.  
(I.E. PS104 IS LOCATED BEHIND A104.)

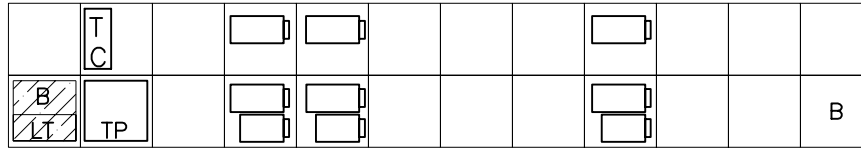

FRONT VIEW



POWER SUPPLIES  
0A-1241-4001

PS ASSY, 2, A-1633; 1, A-1591 RGB



POWER TERMINATION BOX  
0A-1241-4004  
ASSY; POWER TERM BOX 120V-\*L



LIGHT DETECTOR  
0A-1215-4001  
ASSY; LIGHT DETECTOR-34MM



FILTER  
EN-1774  
FILTER W/ WEATHERSTRIP

B

FAN  
0A-1213-4010  
B-1019 W/HARDWARE



THERMOSTAT  
0A-1213-4024  
ENCLOSURE; THERMOSTAT 85-70-9L  
MOUNTED ON VERTICAL.



CONTROLLER BOARD  
0A-1146-0067  
CONTROLLER BOARD

NOTES:

- 10.64" FOR MODULE SIZE

PROJ:	GALAXY, LOVERED V1500 RGB 34MM	
TITLE:	COMP. LAYOUT DIAGRAM; AF-3065-1696-34-RGB	
DES. BY:	MAMMENGGA	DRAWN BY: JMMAMMENGGA
DATE:	23MAY01	
REVISION	APPR. BY:	
SCALE:	NONE	
	1241-E10A-149334	

DAKTRONICS, INC. BROOKINGS, SD 57006

REV.	01
DATE	06SEP01
DESCRIPTION	CORRECTED POWER SUPPLY LOCATION NOTE
BY	BGB
APPR.	

DENOTES POWER SUPPLY LOCATION.  
(I.E. PS104 IS LOCATED BEHIND A104.)

PS104

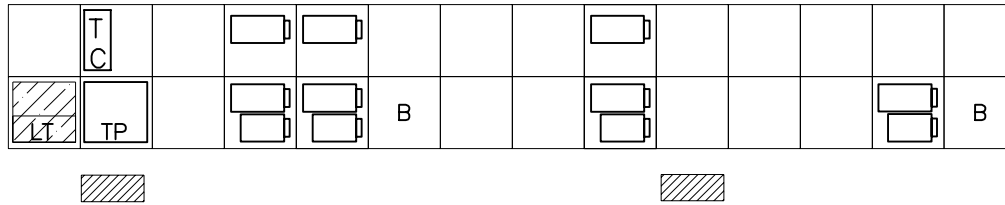

FRONT VIEW

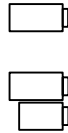

POWER SUPPLIES  
0A-1241-4001  
PS ASSY, 2, A-1633; 1, A-1591 RGB



POWER TERMINATION BOX  
0A-1241-4004  
ASSY; POWER TERM BOX 120V-\*L



FAN  
0A-1213-4010  
B-1019 W/HARDWARE



LIGHT DETECTOR  
0A-1215-4001  
ASSY; LIGHT DETECTOR-34MM



FILTER  
EN-1774  
FILTER W/ WEATHERSTRIP



THERMOSTAT  
0A-1213-4024  
ENCLOSURE; THERMOSTAT 85-70-9L  
MOUNTED ON VERTICAL.



CONTROLLER BOARD  
0A-1146-0067  
CONTROLLER BOARD



POWER SUPPLIES  
0A-1213-4034  
PS ASSY, (1, A-1591, 1, A-1633)

NOTES:

1. 10.64" FOR MODULE SIZE

DAKTRONICS, INC. BROOKINGS, SD 57006	
PROJ: GALAXY, LOVERED V1500 RGB 34MM	
TITLE: COMP. LAYOUT DIAGRAM: AF-3065-16112-34-RGB	
DES. BY: MMAMMENGA	DRAWN BY: JMMAMMENGA
APPR. BY:	DATE: 23MAY01
REVISION	
SCALE: NONE	1241-E10A-149336

REV.	01
DATE	06SEP01
DESCRIPTION	CORRECTED POWER SUPPLY LOCATION NOTE
BY	BGB
APPR.	

DENOTES POWER SUPPLY LOCATION.  
(I.E. PS104 IS LOCATED BEHIND A104.)

→ PS104

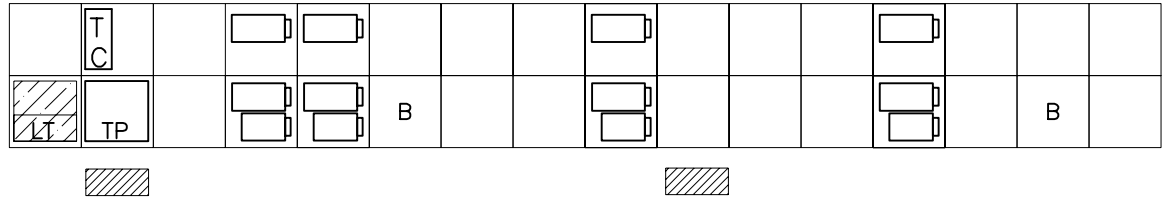

FRONT VIEW

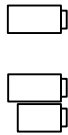

POWER SUPPLIES  
0A-1241-4001

PS ASSY, 2, A-1633; 1, A-1591 RGB



POWER TERMINATION BOX  
0A-1241-4004  
ASSY; POWER TERM BOX 120V-\*L

B  
FAN

0A-1213-4010  
B-1019 W/HARDWARE



LIGHT DETECTOR  
0A-1215-4001  
ASSY; LIGHT DETECTOR-34MM



FILTER  
EN-1774  
FILTER W/ WEATHERSTRIP



THERMOSTAT  
0A-1213-4024  
ENCLOSURE; THERMOSTAT 85-70-9L  
MOUNTED ON VERTICAL.



CONTROLLER BOARD  
0A-1146-0067  
CONTROLLER BOARD

NOTES:

1. 10.64" FOR MODULE SIZE

PROJ:	GALAXY, LOUVERED V1500 RGB 34MM	
TITLE:	COMP. LAYOUT DIAGRAM; AF-3065-16128-34-RGB	
DES. BY:	MAMMENGA	DRAWN BY: JMAMMENGA
DATE:	23MAY01	
REVISION	APPR. BY:	1241-E10A-149342
SCALE:	NONE	

DAKTRONICS, INC. BROOKINGS, SD 57006

REV.	01
DATE	06SEP01
DESCRIPTION	CORRECTED POWER SUPPLY LOCATION NOTE
BY	BGB
APPR.	

DENOTES POWER SUPPLY LOCATION.  
(I.E. PS104 IS LOCATED BEHIND A104.)

→ PS104

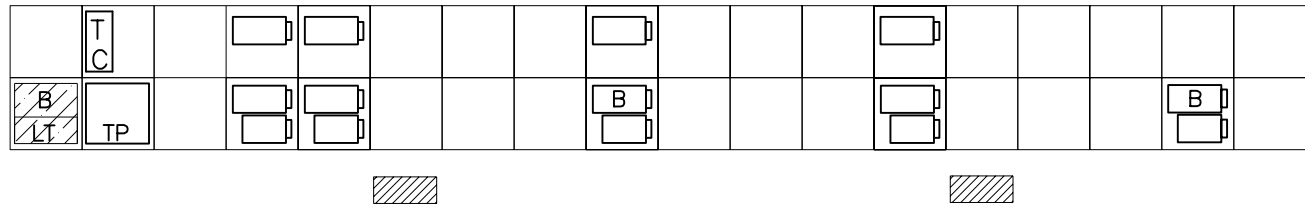

FRONT VIEW



POWER SUPPLIES  
0A-1241-4001  
PS ASSY, 2, A-1633; 1, A-1591 RGB



POWER TERMINATION BOX  
0A-1241-4004  
ASSY; POWER TERM BOX 120V-\*L



LIGHT DETECTOR  
0A-1215-4001  
ASSY; LIGHT DETECTOR-34MM



FILTER  
EN-1774  
FILTER W/ WEATHERSTRIP



THERMOSTAT  
0A-1213-4024  
ENCLOSURE; THERMOSTAT 85-70-9L  
MOUNTED ON VERTICAL.



CONTROLLER BOARD  
0A-1146-0067  
CONTROLLER BOARD



POWER SUPPLIES  
0A-1213-4034  
PS ASSY, (1, A-1591, 1, A-1633)

NOTES:

1. 10.64" FOR MODULE SIZE

PROJ:	GALAXY, LOUVERED V1500 RGB 34MM	
TITLE:	COMP. LAYOUT DIAGRAM; AF-3065-16144-34-RGB	
DES. BY:	MAMMENGA	DRAWN BY: JMAMMENGA
DATE:	23MAY01	
REVISION	APPR. BY:	1241E10A-149347
SCALE:	NONE	

DAKTRONICS, INC. BROOKINGS, SD 57006

REV.	01
DATE	11SEP01
DESCRIPTION	CORRECTED POWER SUPPLY LOCATION NOTE CHANGED POWER TERM BOX USED.
BY	BGB
APPR.	

DENOTES POWER SUPPLY LOCATION.  
(I.E. PS102 IS LOCATED BEHIND A102.)

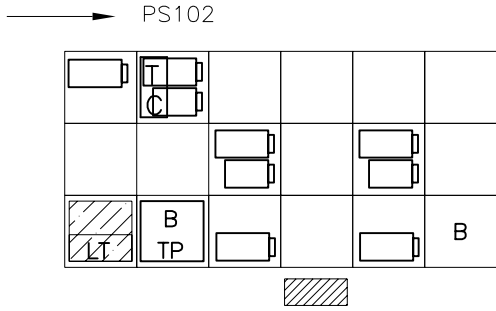

FRONT VIEW

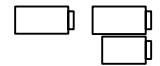

POWER SUPPLIES  
0A-1241-4001  
PS ASSY, 2, A-1633; 1, A-1591 RGB



POWER TERMINATION BOX  
0A-1241-4003  
ASSY; POWER TERM BOX 120V-\*L



FAN  
0A-1213-4010  
B-1019 W/HARDWARE



LIGHT DETECTOR  
0A-1215-4001  
ASSY; LIGHT DETECTOR-34MM



FILTER  
EN-1774  
FILTER W/ WEATHERSTRIP



THERMOSTAT  
0A-1213-4024  
ENCLOSURE; THERMOSTAT 85-70-9L  
MOUNTED ON VERTICAL.



CONTROLLER BOARD  
0A-1146-0067  
CONTROLLER BOARD

NOTES:

- 10.64" FOR MODULE SIZE

DAKTRONICS, INC. BROOKINGS, SD 57006	
PROJ:	GALAXY, LOVERED V1500 RGB 34MM
TITLE:	COMP. LAYOUT DIAGRAM; AF-3065-2448-34-RGB
DES. BY:	MAMAMENGA
DRAWN BY:	JMAMAMENGA
DATE:	23MAY01
REVISION	
APPR. BY:	
SCALE:	NONE
1241-E10A-149349	

REV.	01
DATE	11SEP01
DESCRIPTION	CORRECTED POWER SUPPLY LOCATION NOTE CHANGED POWER TERM BOX USED.
BY	BGB
APPR.	

DENOTES POWER SUPPLY LOCATION.  
(I.E. PS102 IS LOCATED BEHIND A102.)

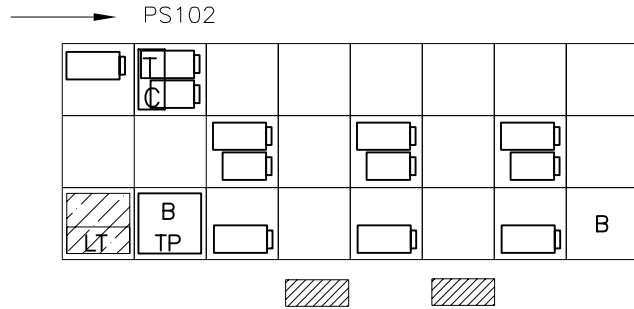

FRONT VIEW

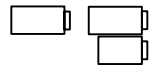

POWER SUPPLIES  
0A-1241-4001  
PS ASSY, 2, A-1633; 1, A-1591 RGB



POWER TERMINATION BOX  
0A-1241-4003  
ASSY; POWER TERM BOX 120V-\*L

B

FAN  
0A-1213-4010  
B-1019 W/HARDWARE



LIGHT DETECTOR  
0A-1215-4001  
ASSY; LIGHT DETECTOR-34MM



THERMOSTAT  
0A-1213-4024  
ENCLOSURE; THERMOSTAT 85-70-9L  
MOUNTED ON VERTICAL.



CONTROLLER BOARD  
0A-1146-0067  
CONTROLLER BOARD



FILTER  
EN-1774  
FILTER W/ WEATHERSTRIP

NOTES:

1. 10.64" FOR MODULE SIZE

PROJ:	GALAXY, LOUVERED V1500 RGB 34MM	
TITLE:	COMP. LAYOUT DIAGRAM; AF-3065-2464-34-RGB	
DES. BY:	MAMMENGGA	DRAWN BY: JMAMMENGGA
DATE:	23MAY01	
REVISION	APPR. BY:	
SCALE:	NONE	
		1241E10A-149357
		DAKTRONICS, INC. BROOKINGS, SD 57006

REV.	01
DATE	11SEP01
DESCRIPTION	CORRECTED POWER SUPPLY LOCATION NOTE CHANGED POWER TERM BOX USED.
BY	BGB
APPR.	

DENOTES POWER SUPPLY LOCATION.  
(I.E. PS102 IS LOCATED BEHIND A102.)

→ PS102

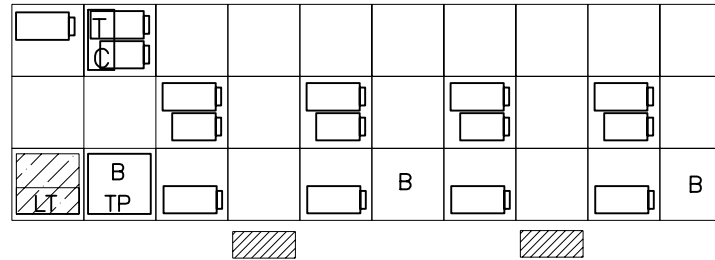

FRONT VIEW

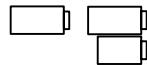

POWER SUPPLIES  
0A-1241-4001  
PS ASSY, 2, A-1633; 1, A-1591 RGB



POWER TERMINATION BOX  
0A-1241-4003  
ASSY; POWER TERM BOX 120V-\*L

B

FAN  
0A-1213-4010  
B-1019 W/HARDWARE



LIGHT DETECTOR  
0A-1215-4001  
ASSY; LIGHT DETECTOR-34MM



THERMOSTAT  
0A-1213-4024  
ENCLOSURE; THERMOSTAT 85-70-9L  
MOUNTED ON VERTICAL.



CONTROLLER BOARD  
0A-1146-0067  
CONTROLLER BOARD



FILTER  
EN-1774  
FILTER W/ WEATHERSTRIP

NOTES:

1. 10.64" FOR MODULE SIZE

DAKTRONICS, INC. BROOKINGS, SD 57006	
PROJ:	GALAXY, LOUVERED V1500 RGB 34MM
TITLE:	COMP. LAYOUT DIAGRAM; AF-3065-2480-34-RGB
DES. BY:	MAMMENGA
DRAWN BY:	JMAMMENGA
DATE:	23 MAY 01
REVISION	
APPR. BY:	
SCALE:	NONE
1241-E10A-149359	



REV.	01
DATE	11SEP01
DESCRIPTION	CORRECTED POWER SUPPLY LOCATION NOTE CHANGED POWER TERM BOX USED.
BY	BGB
APPR.	

DENOTES POWER SUPPLY LOCATION.  
(I.E. PS102 IS LOCATED BEHIND A102.) → PS102

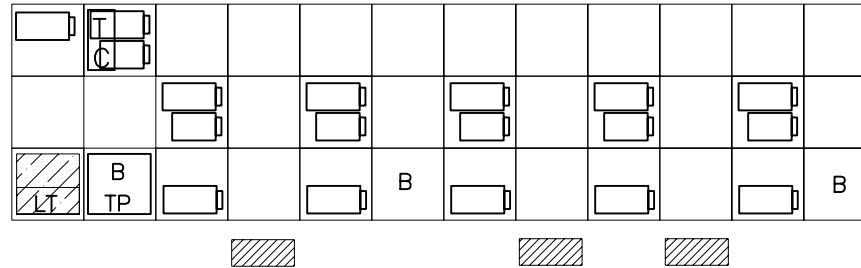

FRONT VIEW

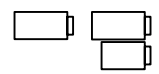

POWER SUPPLIES  
0A-1241-4001  
PS ASSY, 2, A-1633; 1, A-1591 RGB

B

FAN  
0A-1213-4010  
B-1019 W/HARDWARE



THERMOSTAT  
0A-1213-4024  
ENCLOSURE; THERMOSTAT 85-70-9L  
MOUNTED ON VERTICAL.



POWER TERMINATION BOX  
0A-1241-4003  
ASSY; POWER TERM BOX 120V-\*L



LIGHT DETECTOR  
0A-1215-4001  
ASSY; LIGHT DETECTOR-34MM



CONTROLLER BOARD  
0A-1146-0067  
CONTROLLER BOARD



FILTER  
EN-1774  
FILTER W/ WEATHERSTRIP

NOTES:

- 10.64" FOR MODULE SIZE

DAKTRONICS, INC. BROOKINGS, SD 57006

PROJ: GALAXY, LOUVERED V1500 RGB 34MM

TITLE: COMP. LAYOUT DIAGRAM; AF-3065-2496-34-RGB

DES. BY: MMAMMENGA DRAWN BY: JMAMMENGA DATE: 23MAY01

REVISION

APPR. BY: NONE

SCALE: NONE

1241-E10A-149361

REV.	01
DATE	11SEP01
DESCRIPTION	CORRECTED POWER SUPPLY LOCATION NOTE CHANGED POWER TERM BOX USED.
BY	BGB
APPR.	

DENOTES POWER SUPPLY LOCATION.  
(I.E. PS102 IS LOCATED BEHIND A102.)

→ PS102

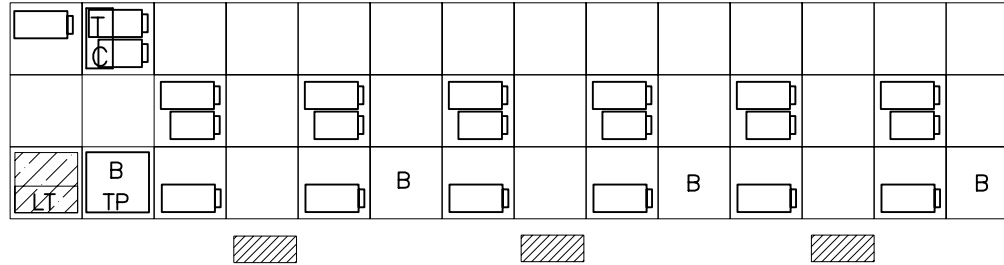

FRONT VIEW

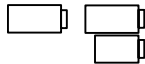

POWER SUPPLIES  
0A-1241-4001  
PS ASSY, 2, A-1633; 1, A-1591 RGB



POWER TERMINATION BOX  
0A-1241-4003  
ASSY; POWER TERM BOX 120V-\*L

B

FAN  
0A-1213-4010  
B-1019 W/HARDWARE



LIGHT DETECTOR  
0A-1215-4001  
ASSY; LIGHT DETECTOR-34MM



FILTER  
EN-1774  
FILTER W/ WEATHERSTRIP



THERMOSTAT  
0A-1213-4024  
ENCLOSURE; THERMOSTAT 85-70-9L  
MOUNTED ON VERTICAL.



CONTROLLER BOARD  
0A-1146-0067  
CONTROLLER BOARD

NOTES:

1. 10.64" FOR MODULE SIZE

DAKTRONICS, INC. BROOKINGS, SD 57006	
PROJ:	GALAXY, LOUVERED V1500 RGB 34MM
TITLE:	COMP. LAYOUT DIAGRAM; AF-3065-24112-34-RGB
DES. BY:	MAMMENGA
DRAWN BY:	JMAMMENGA
DATE:	23MAY01
REVISION	
APPR. BY:	
SCALE:	NONE
1241-E10A-149364	

REV.	01
DATE	11SEP01
DESCRIPTION	CORRECTED POWER SUPPLY LOCATION NOTE CHANGED POWER TERM BOX USED.
BY	BGB
APPR.	

DENOTES POWER SUPPLY LOCATION.  
(I.E. PS102 IS LOCATED BEHIND A102.)

→ PS102

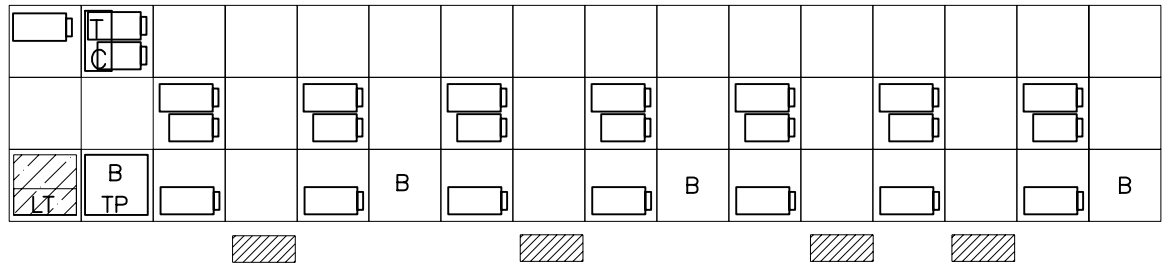

FRONT VIEW

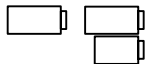

POWER SUPPLIES  
**0A-1241-4001**  
 PS ASSY, 2, A-1633; 1, A-1591 RGB



POWER TERMINATION BOX  
**0A-1241-4003**  
 ASSY; POWER TERM BOX 120V-\*L



FAN  
**0A-1213-4010**  
 B-1019 W/HARDWARE



LIGHT DETECTOR  
**0A-1215-4001**  
 ASSY; LIGHT DETECTOR-34MM



FILTER  
**EN-1774**  
 FILTER W/ WEATHERSTRIP



THERMOSTAT  
**0A-1213-4024**  
 ENCLOSURE; THERMOSTAT 85-70-9L  
 MOUNTED ON VERTICAL.



CONTROLLER BOARD  
**0A-1146-0067**  
 CONTROLLER BOARD

NOTES:

1. 10.64" FOR MODULE SIZE

DAKTRONICS, INC. BROOKINGS, SD 57006	
PROJ: GALAXY, LOUVERED V1500 RGB 34MM	
TITLE: COMP. LAYOUT DIAGRAM; AF-3065-24128-34-RGB	
DES. BY: MMAMMENGA	DRAWN BY: JMAMMENGA
APPR. BY: NONE	DATE: 23MAY01
REVISION	1241-E10A-149365
SCALE: NONE	

REV.	01
DATE	11SEP01
DESCRIPTION	CORRECTED POWER SUPPLY LOCATION NOTE CHANGED POWER TERM BOX USED.
BY	BGB
APPR.	

DENOTES POWER SUPPLY LOCATION.  
(I.E. PS102 IS LOCATED BEHIND A102.)

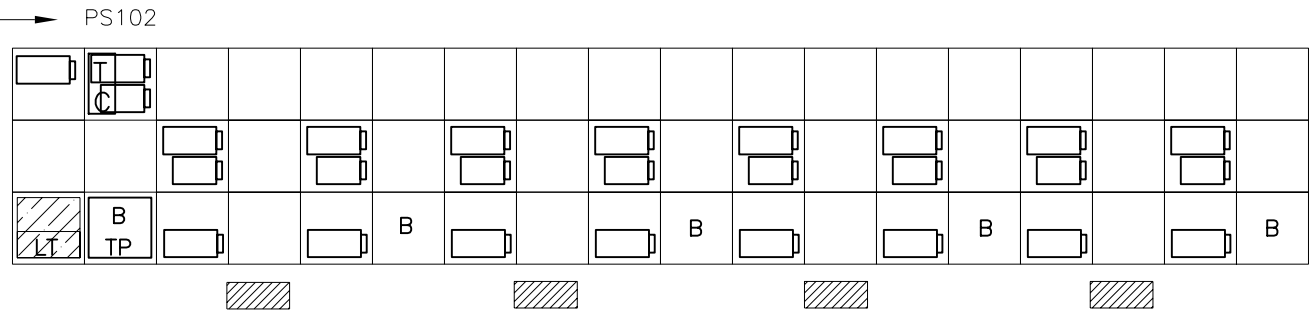

FRONT VIEW

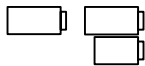

POWER SUPPLIES  
0A-1241-4001  
PS ASSY, 2, A-1633; 1, A-1591 RGB

B

FAN  
0A-1213-4010  
B-1019 W/HARDWARE



THERMOSTAT  
0A-1213-4024  
ENCLOSURE; THERMOSTAT 85-70-9L  
MOUNTED ON VERTICAL.



POWER TERMINATION BOX  
0A-1241-4003  
ASSY; POWER TERM BOX 120V-\*L



LIGHT DETECTOR  
0A-1215-4001  
ASSY; LIGHT DETECTOR-34MM



CONTROLLER BOARD  
0A-1146-0067  
CONTROLLER BOARD



FILTER  
EN-1774  
FILTER W/ WEATHERSTRIP

NOTES:

1. 10.64" FOR MODULE SIZE

DAKTRONICS, INC. BROOKINGS, SD 57006	
PROJ: GALAXY, LOUVERED V1500 RGB 34MM	
TITLE: COMP. LAYOUT DIAGRAM; AF-3065-24144-34-RGB	
DES. BY: MAMMENGCA	DRAWN BY: JAMMENGCA
APPR. BY: MAMMENGCA	DATE: 23MAY01
REVISION	1241-E10A-149368
SCALE: NONE	

REV.	01
DATE	07SEP01
DESCRIPTION	CORRECTED POWER SUPPLY LOCATION NOTE
BY	BGB
APPR.	

DENOTES POWER SUPPLY LOCATION.  
(I.E. PS303 IS LOCATED BEHIND A303).

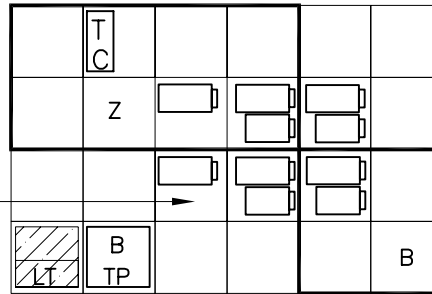

FRONT VIEW

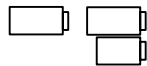

POWER SUPPLIES  
0A-1241-4001

PS ASSY, 2, A-1633; 1, A-1591 RGB



POWER TERMINATION BOX  
0A-1241-4003  
ASSY; POWER TERM BOX 120V-\*L

Z

LINE FILTER  
0A-1241-4002  
Z-FILTER ASSY. 2 W/GND BAR

B

FAN

0A-1213-4010  
B-1019 W/HARDWARE



LIGHT DETECTOR  
0A-1215-4001  
ASSY; LIGHT DETECTOR-34MM



FILTER  
EN-1774  
FILTER W/ WEATHERSTRIP



THERMOSTAT

0A-1213-4024  
ENCLOSURE; THERMOSTAT 85-70-9L  
MOUNTED ON VERTICAL.



CONTROLLER BOARD  
0A-1146-0067  
CONTROLLER BOARD



POWER SUPPLIES  
0A-1213-4034  
PS ASSY, (1, A-1591, 1, A-1633)

NOTES:

1. 10.64" FOR MODULE SIZE

DAKTRONICS, INC. BROOKINGS, SD 57006	
PROJ:	GALAXY, LOVERED V1500 RGB 34MM
TITLE:	COMP. LAYOUT DIAGRAM; AF-3065-3248-34-RGB
DES. BY:	MAMAMENGA
DRAWN BY:	JMAMAMENGA
DATE:	23MAY01
REVISION	
APPR. BY:	
SCALE:	NONE
1241-E10A-149402	

REV.	01
DATE	07SEP01
DESCRIPTION	CORRECTED POWER SUPPLY LOCATION NOTE
BY	BGB
APPR.	

PROJ:	GALAXY, LOVERED V1500 RGB 34MM	
TITLE:	COMP. LAYOUT DIAGRAM; AF-3065-3264-34-RGB	
DES. BY:	MAMMENGA	DRAWN BY: JAMMENGA
DATE:	23MAY01	
REVISION	APPR. BY:	
SCALE:	NONE	
	1241-E10A-149407	

DAKTRONICS, INC. BROOKINGS, SD 57006

DENOTES POWER SUPPLY LOCATION.  
(I.E. PS303 IS LOCATED BEHIND A303).

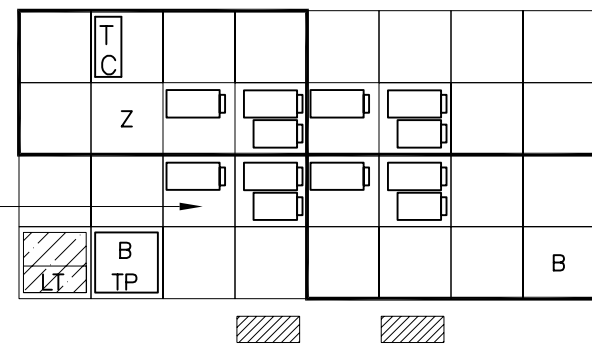

FRONT VIEW

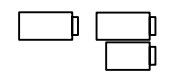

POWER SUPPLIES  
**0A-1241-4001**  
 PS ASSY, 2, A-1633; 1, A-1591 RGB



POWER TERMINATION BOX  
**0A-1241-4003**  
 ASSY; POWER TERM BOX 120V-\*L



FAN  
**0A-1213-4010**  
 B-1019 W/HARDWARE



LIGHT DETECTOR  
**0A-1215-4001**  
 ASSY; LIGHT DETECTOR-34MM



FILTER  
**EN-1774**  
 FILTER W/ WEATHERSTRIP



THERMOSTAT  
**0A-1213-4024**  
 ENCLOSURE; THERMOSTAT 85-70-9L  
 MOUNTED ON VERTICAL.



CONTROLLER BOARD  
**0A-1146-0067**  
 CONTROLLER BOARD



LINE FILTER  
**0A-1241-4002**  
 Z-FILTER ASSY. 2 W/GND BAR

NOTES:

1. 10.64" FOR MODULE SIZE

REV.	01
DATE	10SEP01
DESCRIPTION	CORRECTED POWER SUPPLY LOCATION NOTE
BY	BGB
APPR.	

DENOTES POWER SUPPLY LOCATION.  
(I.E. PS303 IS LOCATED BEHIND A303).

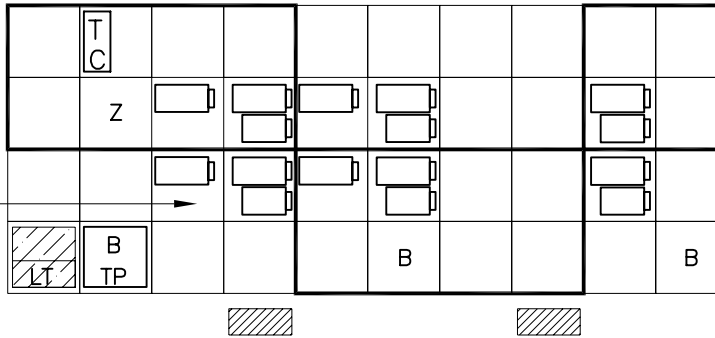

FRONT VIEW

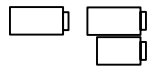

POWER SUPPLIES  
0A-1241-4001  
PS ASSY, 2, A-1633; 1, A-1591 RGB



POWER TERMINATION BOX  
0A-1241-4003  
ASSY; POWER TERM BOX 120V-\*L

Z

LINE FILTER  
0A-1241-4002  
Z-FILTER ASSY. 2 W/GND BAR

B

FAN  
0A-1213-4010  
B-1019 W/HARDWARE



LIGHT DETECTOR  
0A-1215-4001  
ASSY; LIGHT DETECTOR-34MM



FILTER  
EN-1774  
FILTER W/ WEATHERSTRIP



THERMOSTAT  
0A-1213-4024  
ENCLOSURE; THERMOSTAT 85-70-9L  
MOUNTED ON VERTICAL.



CONTROLLER BOARD  
0A-1146-0067  
CONTROLLER BOARD



POWER SUPPLIES  
0A-1213-4034  
PS ASSY, (1, A-1591, 1, A-1633)

NOTES:

1. 10.64" FOR MODULE SIZE

PROJ:	GALAXY, LOUVERED V1500 RGB 34MM	
TITLE:	COMP. LAYOUT DIAGRAM; AF-3065-3280-34-RGB	
DES. BY:	MAMMENGGA	DRAWN BY: JAMMENGGA
DATE:	23MAY01	
REVISION	APPR. BY:	1241-E10A-149408
SCALE:	NONE	
		DAKTRONICS, INC. BROOKINGS, SD 57006

REV.	01
DATE	10SEP01
DESCRIPTION	CORRECTED POWER SUPPLY LOCATION NOTE
BY	BGB
APPR.	

PROJ:	GALAXY, LOVERED V1500 RGB 34MM	
TITLE:	COMP. LAYOUT DIAGRAM; AF-3065-3296-34-RGB	
DES. BY:	MAMMENGA	DRAWN BY: JAMMENGA
DATE:	23MAY01	
REVISION	APPR. BY:	
SCALE:	NONE	
	1241-E10A-149420	

DAKTRONICS, INC. BROOKINGS, SD 57006

DENOTES POWER SUPPLY LOCATION.  
(I.E. PS303 IS LOCATED BEHIND A303).

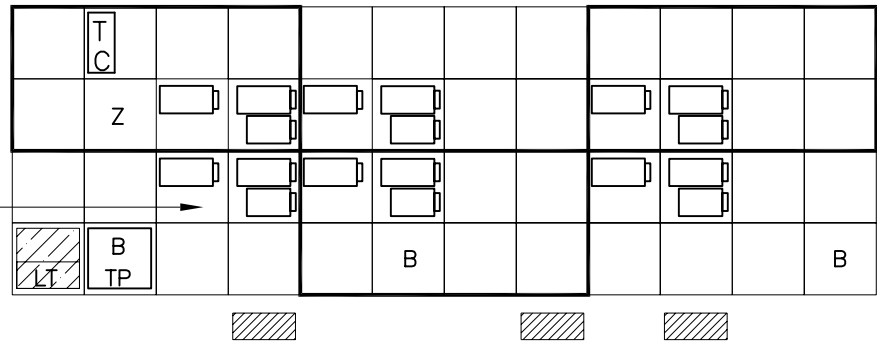

FRONT VIEW

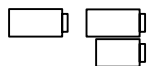

POWER SUPPLIES  
0A-1241-4001  
PS ASSY, 2, A-1633; 1, A-1591 RGB



POWER TERMINATION BOX  
0A-1241-4003  
ASSY; POWER TERM BOX 120V-\*L

B

FAN  
0A-1213-4010  
B-1019 W/HARDWARE



LIGHT DETECTOR  
0A-1215-4001  
ASSY; LIGHT DETECTOR-34MM



FILTER  
EN-1774  
FILTER W/ WEATHERSTRIP



THERMOSTAT  
0A-1213-4024  
ENCLOSURE; THERMOSTAT 85-70-9L  
MOUNTED ON VERTICAL.



CONTROLLER BOARD  
0A-1146-0067  
CONTROLLER BOARD

Z

LINE FILTER  
0A-1241-4002  
Z-FILTER ASSY. 2 W/GND BAR

NOTES:

1. 10.64" FOR MODULE SIZE



REV.	01
DATE	10SEP01
DESCRIPTION	CORRECTED POWER SUPPLY LOCATION NOTE
BY	BGB
APPR.	

DENOTES POWER SUPPLY LOCATION.  
(I.E. PS303 IS LOCATED BEHIND A303).

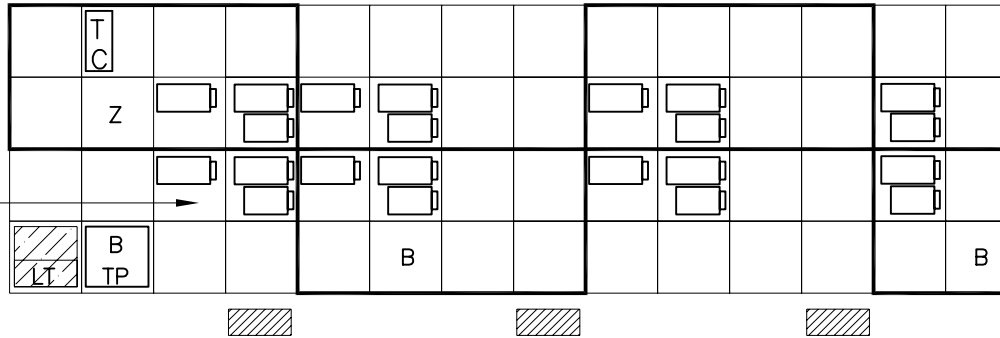

FRONT VIEW

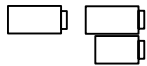

POWER SUPPLIES  
**0A-1241-4001**  
PS ASSY, 2, A-1633; 1, A-1591 RGB

**B**

FAN  
0A-1213-4010  
B-1019 W/HARDWARE

**TC**

THERMOSTAT  
0A-1213-4024  
ENCLOSURE; THERMOSTAT 85-70-9L  
MOUNTED ON VERTICAL.



POWER TERMINATION BOX  
0A-1241-4003  
ASSY; POWER TERM BOX 120V-\*L



LIGHT DETECTOR  
0A-1215-4001  
ASSY; LIGHT DETECTOR-34MM



CONTROLLER BOARD  
0A-1146-0067  
CONTROLLER BOARD

**Z**

LINE FILTER  
0A-1241-4002  
Z-FILTER ASSY. 2 W/GND BAR



FILTER  
EN-1774  
FILTER W/ WEATHERSTRIP



POWER SUPPLIES  
0A-1213-4034  
PS ASSY, (1, A-1591, 1, A-1633)

NOTES:

1. 10.64" FOR MODULE SIZE

PROJ:	GALAXY, LOUVERED V1500 RGB 34MM
TITLE:	COMP. LAYOUT DIAGRAM; AF-3065-32112-34-RGB
DES. BY:	MMAMMENGA
DRAWN BY:	JMAMMENGA
DATE:	23MAY01
REVISION	APPR. BY:
SCALE:	NONE
	1241E10A-149421

DAKTRONICS, INC. BROOKINGS, SD 57006

REV.	01
DATE	10SEP01
DESCRIPTION	CORRECTED POWER SUPPLY LOCATION NOTE
BY	BGB
APPR.	

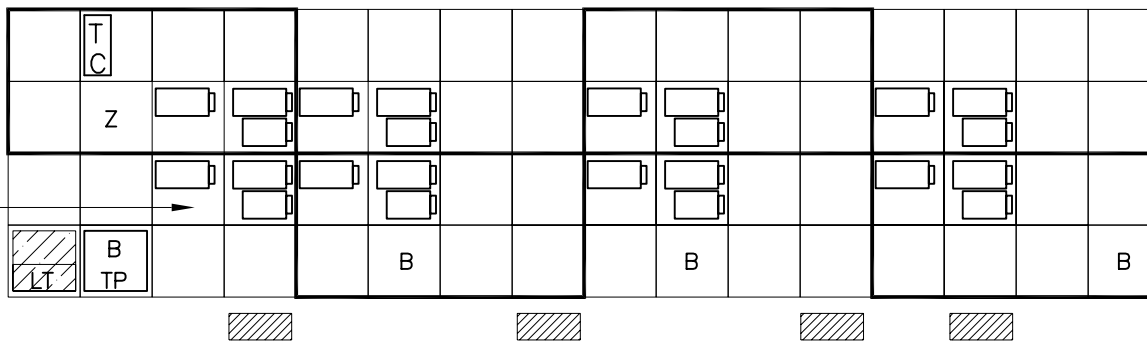

FRONT VIEW

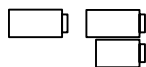

POWER SUPPLIES  
**0A-1241-4001**  
 PS ASSY, 2, A-1633; 1, A-1591 RGB



POWER TERMINATION BOX  
**0A-1241-4003**  
 ASSY; POWER TERM BOX 120V-\*L

**B**  
 FAN  
**0A-1213-4010**  
 B-1019 W/HARDWARE



LIGHT DETECTOR  
**0A-1215-4001**  
 ASSY; LIGHT DETECTOR-34MM



FILTER  
**EN-1774**  
 FILTER W/ WEATHERSTRIP



THERMOSTAT  
**0A-1213-4024**  
 ENCLOSURE; THERMOSTAT 85-70-9L  
 MOUNTED ON VERTICAL.



CONTROLLER BOARD  
**0A-1146-0067**  
 CONTROLLER BOARD



LINE FILTER  
**0A-1241-4002**  
 Z-FILTER ASSY. 2 W/GND BAR

NOTES:

1. 10.64" FOR MODULE SIZE

DAKTRONICS, INC. BROOKINGS, SD 57006

PROJ: GALAXY, LOVERED V1500 RGB 34MM

TITLE: COMP. LAYOUT DIAGRAM; AF-3065-32128-34-RGB

DES. BY: MMAMMENGA DRAWN BY: JMMAMMENGA DATE: 23MAY01

REVISION APPR. BY: SCALE: NONE

1241-E10A-149422

REV.	01
DATE	10SEP01
DESCRIPTION	CORRECTED POWER SUPPLY LOCATION NOTE
BY	BGB
APPR.	

DENOTES POWER SUPPLY LOCATION.  
 (I.E. PS303 IS LOCATED BEHIND A303).

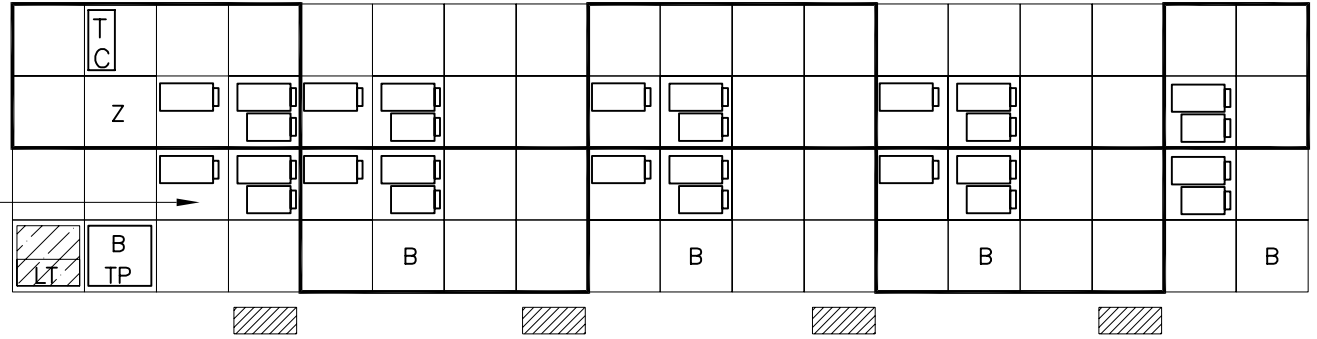

FRONT VIEW

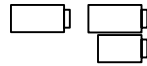

POWER SUPPLIES  
**0A-1241-4001**  
 PS ASSY, 2, A-1633; 1, A-1591 RGB



POWER TERMINATION BOX  
**0A-1241-4003**  
 ASSY; POWER TERM BOX 120V-\*L

Z

LINE FILTER  
**0A-1241-4002**  
 Z-FILTER ASSY. 2 W/GND BAR

NOTES:

1. 10.64" FOR MODULE SIZE

B

FAN  
**0A-1213-4010**  
 B-1019 W/HARDWARE



LIGHT DETECTOR  
**0A-1215-4001**  
 ASSY; LIGHT DETECTOR-34MM



FILTER  
**EN-1774**  
 FILTER W/ WEATHERSTRIP



THERMOSTAT  
**0A-1213-4024**  
 ENCLOSURE; THERMOSTAT 85-70-9L  
 MOUNTED ON VERTICAL.



CONTROLLER BOARD  
**0A-1146-0067**  
 CONTROLLER BOARD



POWER SUPPLIES  
**0A-1213-4034**  
 PS ASSY, (1, A-1591, 1, A-1633)

DAKTRONICS, INC. BROOKINGS, SD 57006  
 PROJ: GALAXY, LOVERED V1500 RGB 34MM  
 TITLE: COMP. LAYOUT DIAGRAM; AF-3065-32144-34-RGB  
 DES. BY: MMAMMENGA DRAWN BY: JMMAMMENGA DATE: 23MAY01  
 REVISION APPR. BY: NONE SCALE: NONE  
 1241-E10A-149427

REV.	01
DATE	10SEP01
DESCRIPTION	CORRECTED POWER SUPPLY LOCATION NOTE
BY	BGB
APPR.	

DENOTES POWER SUPPLY LOCATION.  
(I.E. PS302 IS LOCATED BEHIND A302.)

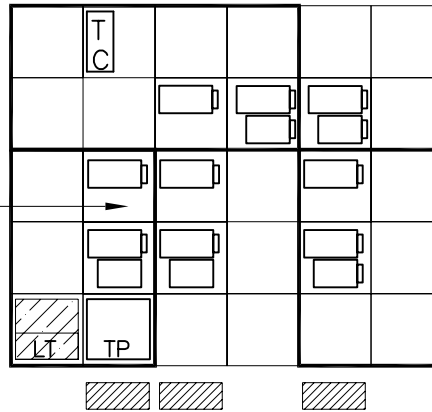

FRONT VIEW

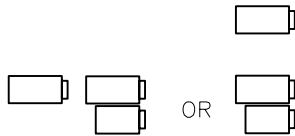

POWER SUPPLIES  
0A-1241-4001

PS ASSY, 2, A-1633; 1, A-1591 RGB



POWER TERMINATION BOX  
0A-1241-4003  
ASSY; POWER TERM BOX 120V-\*L



LIGHT DETECTOR  
0A-1215-4001  
ASSY; LIGHT DETECTOR-34MM



FILTER  
EN-1774  
FILTER W/ WEATHERSTRIP



THERMOSTAT  
0A-1213-4024  
ENCLOSURE; THERMOSTAT 85-70-9L  
MOUNTED ON VERTICAL.



CONTROLLER BOARD  
0A-1146-0067  
CONTROLLER BOARD



POWER SUPPLIES  
0A-1213-4034  
PS ASSY, (1, A-1591, 1, A-1633)

NOTES:

1. 10.64" FOR MODULE SIZE

PROJ:	GALAXY, LOUVERED V1500 RGB 34MM	
TITLE:	COMP. LAYOUT DIAGRAM; AF-3065-4048-34-RGB	
DES. BY:	MAMMENGA	DRAWN BY: JAMMENGA
DATE:	23MAY01	
REVISION	APPR. BY:	
SCALE:	NONE	
	1241-E10A-149429	

DAKTRONICS, INC. BROOKINGS, SD 57006

REV.	DATE	DESCRIPTION	BY	APPR.
02	27AUG2002	CHANGED 0.219 HOLES TO 0.266 TO ACCOMMODATE HARDWARE @4	EJY	
01	27JUN01	CHANGED LAYOUT OF COMPONENTS, CHANGED PLACEMENT OF 2.00" HOLES, REDUCE FROM THREE TO TWO, 2 HOLES.	MDM	

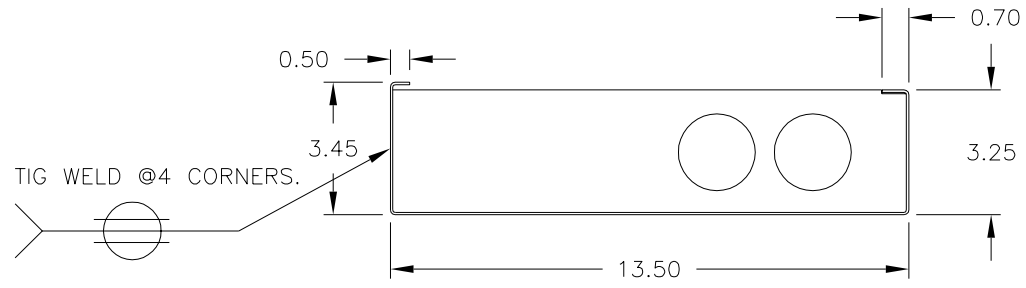

FRONT VIEW

UNLESS OTHERWISE SPECIFIED.  
 DIMENSIONS ARE IN INCHES.  
 DO NOT SCALE DRAWING.  
 TOLERANCES:  

FRACTIONS	ANGLES	DECIMALS
±1/16 (0.063)	±1.5 DEG.	X.X ±0.016
EXCEPT HOLES		X.XX ±0.008
		X.XXX ±0.004

FINISH: NONE  
 PART NAME: TERM BOX  
 PART NUMBER: 0M-149554  
 LAYOUT DIMENSION: 14.760 X 20.920  
 RAW MATERIAL QUANTITY: 2.144 FT2  
 MATERIAL SPECIFICATION: HEX 011

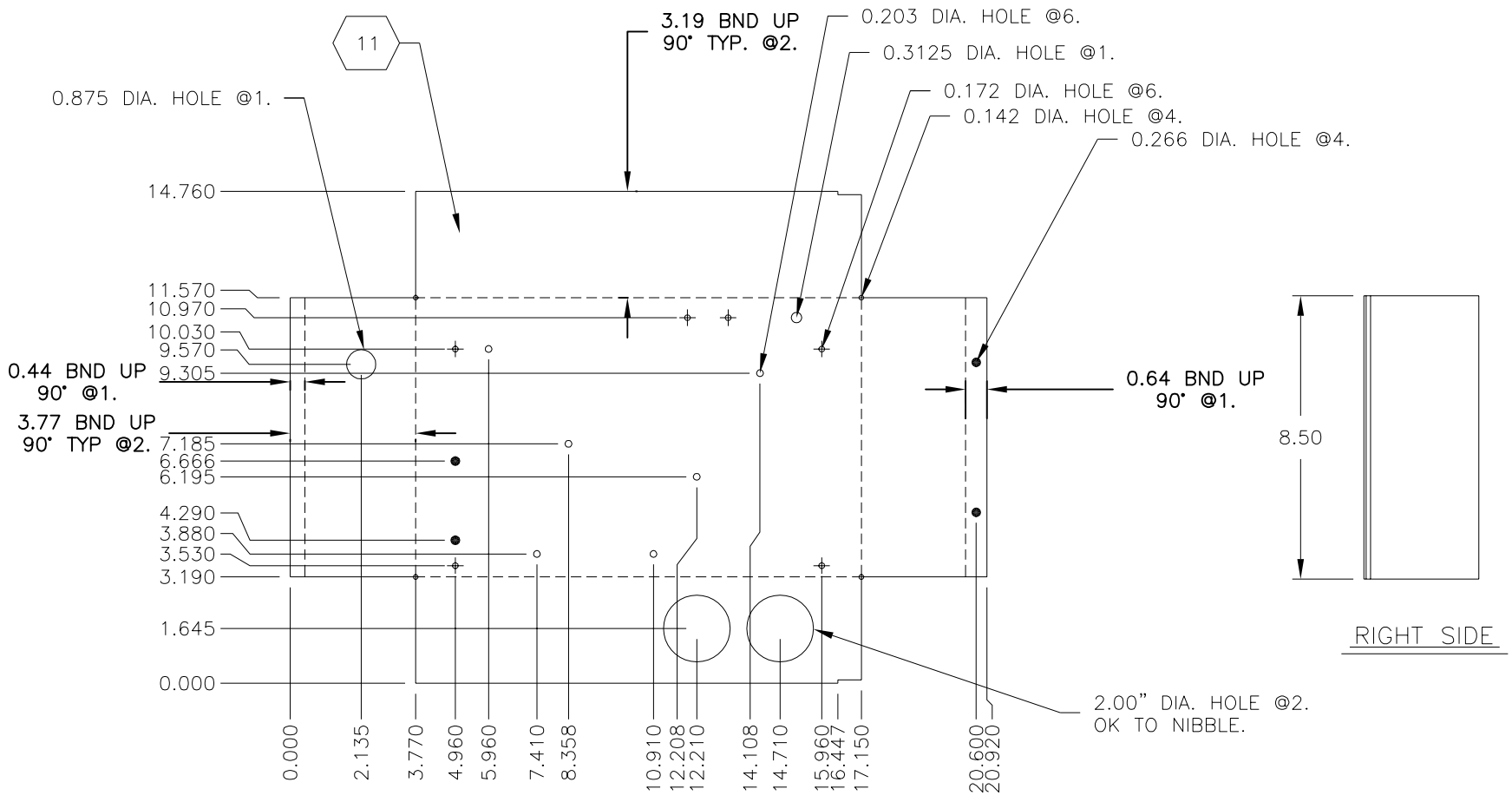

LAYOUT VIEW

RIGHT SIDE

DAKTRONICS, INC. BROOKINGS, SD 57006	
PROJ: GALAXY, LOUVERED V1500 RGB BOX	
TITLE: POWER TERMINATION BOX	
DES. BY: MMAMMENGA	DRAWN BY: MMAMMENGA
DATE: 25MAY01	
REVISION	APPR. BY:
SCALE: 1=5*	1241-E07A-149554

REV.	01
DATE	10SEP01
DESCRIPTION	CORRECTED POWER SUPPLY LOCATION NOTE
BY	BGB
APPR.	

PROJ:	GALAXY, LOVERED V1500 RGB 34MM	
TITLE:	COMP. LAYOUT DIAGRAM; AF-3065-4064-34-RGB	
DES. BY:	MAMAMENGA	DRAWN BY: JAMAMENGA
DATE:	23MAY01	
REVISION	APPR. BY:	
SCALE:	NONE	
	1241-E10A-149460	

DAKTRONICS, INC. BROOKINGS, SD 57006

DENOTES POWER SUPPLY LOCATION.  
(I.E. PS302 IS LOCATED BEHIND A302.)

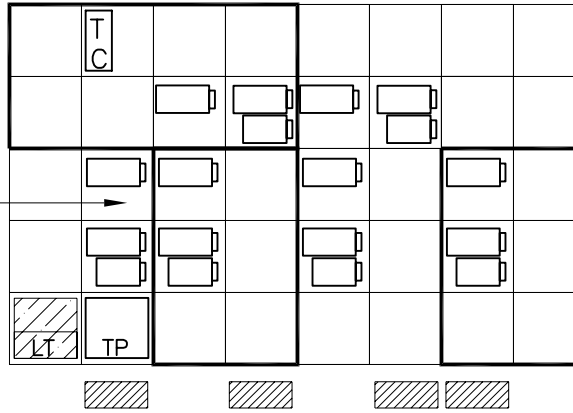

FRONT VIEW

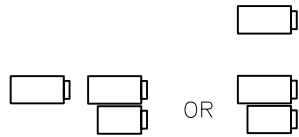

POWER SUPPLIES  
0A-1241-4001

PS ASSY, 2, A-1633; 1, A-1591 RGB



POWER TERMINATION BOX  
0A-1241-4003  
ASSY; POWER TERM BOX 120V-\*L

B

FAN  
0A-1213-4010  
B-1019 W/HARDWARE



LIGHT DETECTOR  
0A-1215-4001  
ASSY; LIGHT DETECTOR-34MM



FILTER  
EN-1774  
FILTER W/ WEATHERSTRIP



THERMOSTAT  
0A-1213-4024  
ENCLOSURE; THERMOSTAT 85-70-9L  
MOUNTED ON VERTICAL.



CONTROLLER BOARD  
0A-1146-0067  
CONTROLLER BOARD

NOTES:

1. 10.64" FOR MODULE SIZE

REV.	01
DATE	10SEP01
DESCRIPTION	CORRECTED POWER SUPPLY LOCATION NOTE
BY	BGB
APPR.	

REVISION	APPR. BY:	1241-E10A-149466
SCALE:	NONE	

DENOTES POWER SUPPLY LOCATION.  
(I.E. PS302 IS LOCATED BEHIND A302.)

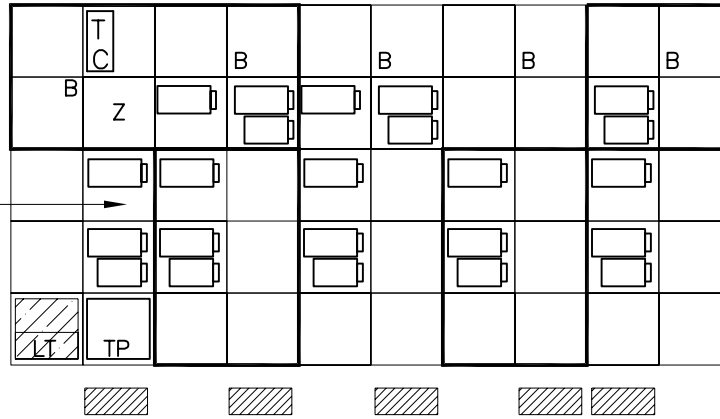

FRONT VIEW

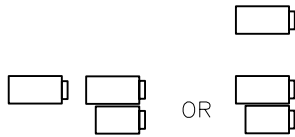

POWER SUPPLIES  
0A-1241-4001

PS ASSY, 2, A-1633; 1, A-1591 RGB



POWER TERMINATION BOX  
0A-1241-4003  
ASSY; POWER TERM BOX 120V-\*L

Z

LINE FILTER  
0A-1241-4002  
Z-FILTER ASSY. 2 W/GND BAR

NOTES:

1. 10.64" FOR MODULE SIZE

B

FAN

0A-1213-4010  
B-1019 W/HARDWARE



LIGHT DETECTOR  
0A-1215-4001  
ASSY; LIGHT DETECTOR-34MM



FILTER  
EN-1774  
FILTER W/ WEATHERSTRIP



THERMOSTAT

0A-1213-4024  
ENCLOSURE; THERMOSTAT 85-70-9L  
MOUNTED ON VERTICAL.



CONTROLLER BOARD  
0A-1146-0067  
CONTROLLER BOARD



POWER SUPPLIES  
0A-1213-4034  
PS ASSY, (1, A-1591, 1, A-1633)

DAKTRONICS, INC. BROOKINGS, SD 57006

PROJ: GALAXY, LOVERED V1500 RGB 34MM  
TITLE: COMP. LAYOUT DIAGRAM; AF-3065-4080-34-RGB  
DES. BY: MMAMMENGA DRAWN BY: JMAMMENGA DATE: 23MAY01

REV.	01
DATE	10SEP01
DESCRIPTION	CORRECTED POWER SUPPLY LOCATION NOTE
BY	BGB
APPR.	



PROJ.	GALAXY, LOVERED V1500 RGB 34MM	
TITLE	COMP. LAYOUT DIAGRAM; AF-3065-4096-34-RGB	
DES. BY:	MAMMENGCA	DRAWN BY: JAMAMMENGCA
DATE:	23MAY01	
REVISION	APPR. BY:	
SCALE:	NONE	
	1241-E10A-149467	

DAKTRONICS, INC. BROOKINGS, SD 57006

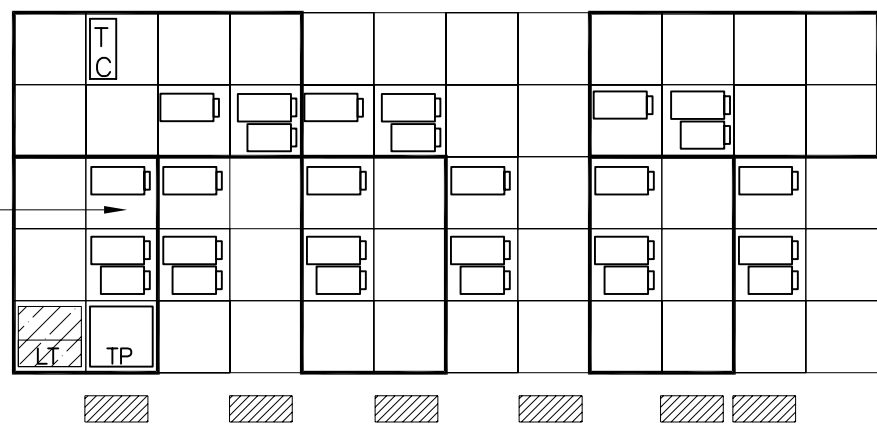
DENOTES POWER SUPPLY LOCATION.  
(I.E. PS302 IS LOCATED BEHIND A302.)





FRONT VIEW

  
 OR   
 POWER SUPPLIES  
 0A-1241-4001  
 PS ASSY, 2, A-1633; 1, A-1591 RGB

  
 POWER TERMINATION BOX  
 0A-1241-4003  
 ASSY; POWER TERM BOX 120V-\*L

B  
 FAN  
 0A-1213-4010  
 B-1019 W/HARDWARE

  
 LIGHT DETECTOR  
 0A-1215-4001  
 ASSY; LIGHT DETECTOR-34MM

  
 FILTER  
 EN-1774  
 FILTER W/ WEATHERSTRIP

  
 THERMOSTAT  
 0A-1213-4024  
 ENCLOSURE; THERMOSTAT 85-70-9L  
 MOUNTED ON VERTICAL.

  
 CONTROLLER BOARD  
 0A-1146-0067  
 CONTROLLER BOARD

NOTES:

- 10.64" FOR MODULE SIZE



REV.	01
DATE	10SEP01
DESCRIPTION	CORRECTED POWER SUPPLY LOCATION NOTE
BY	BGB
APPR.	

PROJ.	GALAXY, LOUVERED V1500 RGB 34MM	
TITLE	COMP. LAYOUT DIAGRAM; AF-3065-40112-34-RGB	
DES. BY:	MAMMENGGA	DRAWN BY: JAMMENGGA
DATE:	23MAY01	
REVISION	APPR. BY:	
SCALE:	NONE	
	1241-E10A-149468	
	DAKTRONICS, INC. BROOKINGS, SD 57006	

DENOTES POWER SUPPLY LOCATION.  
(I.E. PS302 IS LOCATED BEHIND A302.)

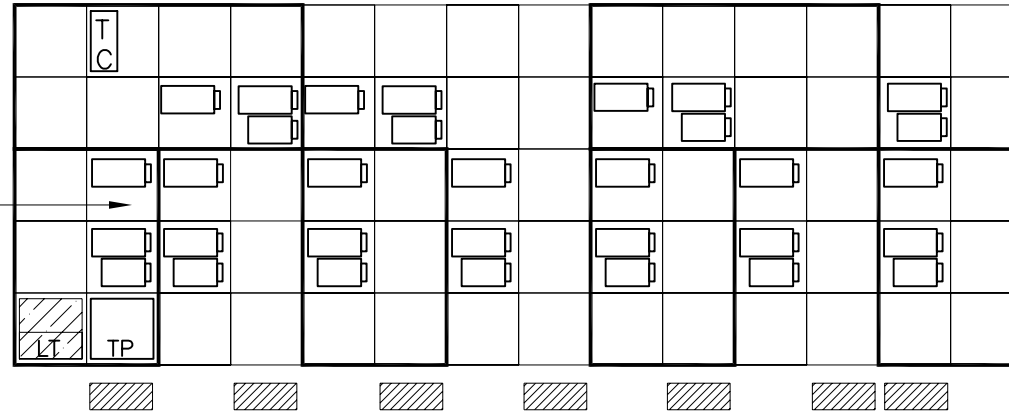

FRONT VIEW

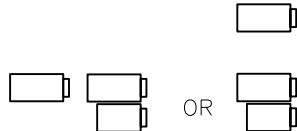

POWER SUPPLIES  
0A-1241-4001  
PS ASSY, 2, A-1633; 1, A-1591 RGB

B  
FAN  
0A-1213-4010  
B-1019 W/HARDWARE

TC  
THERMOSTAT  
0A-1213-4024  
ENCLOSURE; THERMOSTAT 85-70-9L  
MOUNTED ON VERTICAL.

TP  
POWER TERMINATION BOX  
0A-1242-4003  
ASSY; POWER TERM BOX 120V-\*L

LT  
LIGHT DETECTOR  
0A-1215-4001  
ASSY; LIGHT DETECTOR-34MM

[Hatched Box]  
CONTROLLER BOARD  
0A-1146-0067  
CONTROLLER BOARD

[Hatched Box]  
FILTER  
EN-1774  
FILTER W/ WEATHERSTRIP

[Power Supply Symbol]  
POWER SUPPLIES  
0A-1213-4034  
PS ASSY, (1, A-1591, 1, A-1633)

NOTES:

1. 10.64" FOR MODULE SIZE

REV.	01
DATE	10SEP01
DESCRIPTION	CORRECTED POWER SUPPLY LOCATION NOTE
BY	BGB
APPR.	

PROJ.	GALAXY, LOUVERED V1500 RGB 34MM	
TITLE	COMP. LAYOUT DIAGRAM; AF-3065-40128-34-RGB	
DES. BY:	MAMMENGGA	DRAWN BY: JAMMENGGA
APPR. BY:		DATE: 23MAY01
REVISION	SCALE:	1241E10A-149471
	NONE	

DAKTRONICS, INC. BROOKINGS, SD 57006

DENOTES POWER SUPPLY LOCATION.  
(I.E. PS302 IS LOCATED BEHIND A302.)

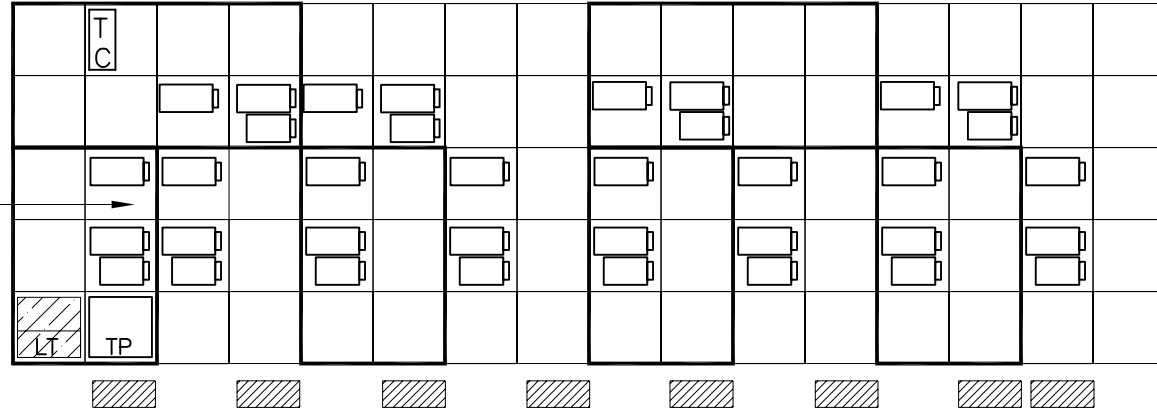

FRONT VIEW

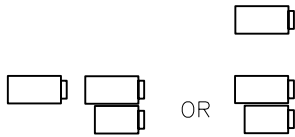

POWER SUPPLIES  
0A-1241-4001  
PS ASSY, 2, A-1633; 1, A-1591 RGB



POWER TERMINATION BOX  
0A-1241-4003  
ASSY; POWER TERM BOX 120V-\*L

B  
FAN  
0A-1213-4010  
B-1019 W/HARDWARE



LIGHT DETECTOR  
0A-1215-4001  
ASSY; LIGHT DETECTOR-34MM



FILTER  
EN-1774  
FILTER W/ WEATHERSTRIP



THERMOSTAT  
0A-1213-4024  
ENCLOSURE; THERMOSTAT 85-70-9L  
MOUNTED ON VERTICAL.



CONTROLLER BOARD  
0A-1146-0067  
CONTROLLER BOARD

NOTES:

1. 10.64" FOR MODULE SIZE

REV.	01
DATE	10SEP01
DESCRIPTION	CORRECTED POWER SUPPLY LOCATION NOTE
BY	BGB
APPR.	

PROJ:	GALAXY, LOVERED V1500 RGB 34MM	
TITLE:	COMP. LAYOUT DIAGRAM; AF-3065-40144-34-RGB	
DES. BY:	MAMMENGA	DRAWN BY: JAMMENGA
DATE:	23MAY01	
REVISION	APPR. BY:	
SCALE:	NONE	
	1241-E10A-149472	
	DAKTRONICS, INC. BROOKINGS, SD 57006	

DENOTES POWER SUPPLY LOCATION.  
(I.E. PS302 IS LOCATED BEHIND A302.)

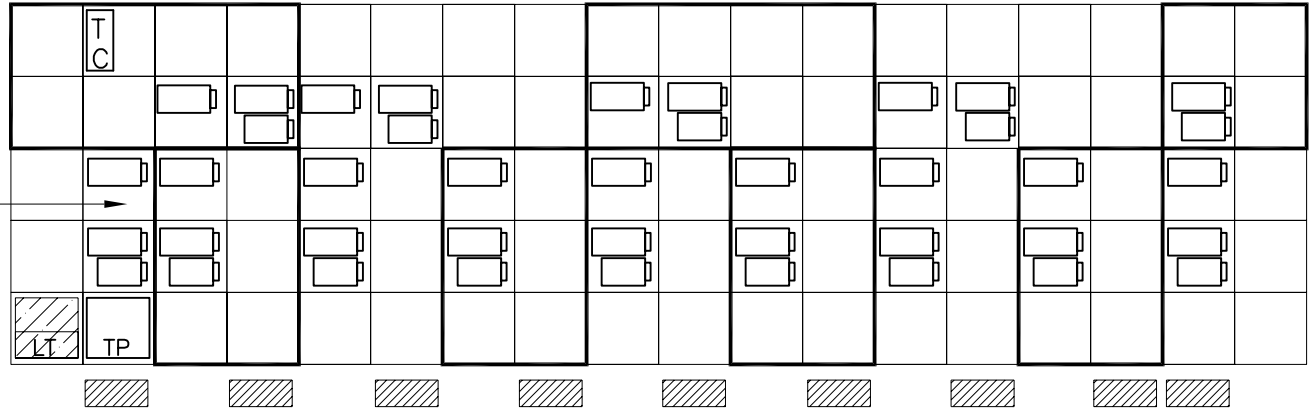

FRONT VIEW

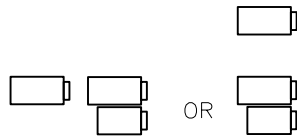

POWER SUPPLIES  
0A-1241-4001  
PS ASSY, 2, A-1633; 1, A-1591 RGB



POWER TERMINATION BOX  
0A-1242-4003  
ASSY; POWER TERM BOX 120V-\*L



LIGHT DETECTOR  
0A-1215-4001  
ASSY; LIGHT DETECTOR-34MM



FILTER  
EN-1774  
FILTER W/ WEATHERSTRIP



THERMOSTAT  
0A-1213-4024  
ENCLOSURE; THERMOSTAT 85-70-9L  
MOUNTED ON VERTICAL.



CONTROLLER BOARD  
0A-1146-0067  
CONTROLLER BOARD



POWER SUPPLIES  
0A-1213-4034  
PS ASSY, (1, A-1591, 1, A-1633)

NOTES:

1. 10.64" FOR MODULE SIZE

REV.	01	10SEP01	CORRECTED POWER SUPPLY LOCATION NOTE	BGB	APPR.
DATE			DESCRIPTION	BY	

DENOTES POWER SUPPLY LOCATION.  
(I.E. PS203 IS LOCATED BEHIND A203.)

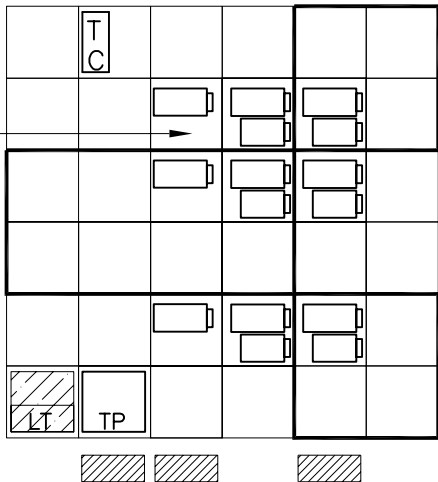

FRONT VIEW

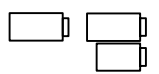

POWER SUPPLIES  
**0A-1241-4001**  
PS ASSY, 2, A-1633; 1, A-1591 RGB



POWER TERMINATION BOX  
0A-1242-4003  
ASSY; POWER TERM BOX 120V-\*L

**B**

FAN  
0A-1213-4010  
B-1019 W/HARDWARE



LIGHT DETECTOR  
0A-1215-4001  
ASSY; LIGHT DETECTOR-34MM



FILTER  
EN-1774  
FILTER W/ WEATHERSTRIP



THERMOSTAT  
0A-1213-4024  
ENCLOSURE; THERMOSTAT 85-70-9L  
MOUNTED ON VERTICAL.



CONTROLLER BOARD  
0A-1146-0067  
CONTROLLER BOARD



POWER SUPPLIES  
0A-1213-4034  
PS ASSY, (1, A-1591, 1, A-1633)

NOTES:

1. 10.64" FOR MODULE SIZE

DAKTRONICS, INC. BROOKINGS, SD 57006	
PROJ: GALAXY, LOUVERED V1500 RGB 34MM	
TITLE: COMP. LAYOUT DIAGRAM; AF-3065-4848-34-RGB	
DES. BY: MMAMMENGA	DRAWN BY: JMAMMENGA
DATE: 23MAY01	
REVISION	APPR. BY:
SCALE: NONE	1241-E10A-149476

REV.	01			
DATE	10SEP01			
DESCRIPTION	CORRECTED POWER SUPPLY LOCATION NOTE			
BY	BGB			
APPR.				

DENOTES POWER SUPPLY LOCATION.  
(I.E. PS303 IS LOCATED BEHIND A303.)

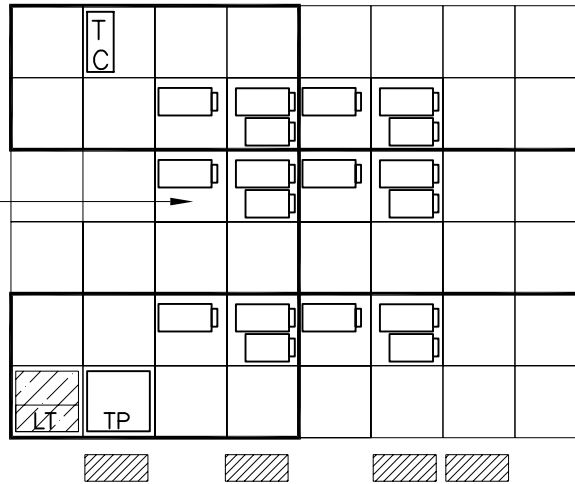

FRONT VIEW

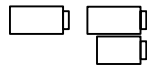

POWER SUPPLIES  
**0A-1241-4001**  
 PS ASSY, 2, A-1633; 1, A-1591 RGB

**B**

FAN  
 0A-1213-4010  
 B-1019 W/HARDWARE



THERMOSTAT  
 0A-1213-4024  
 ENCLOSURE; THERMOSTAT 85-70-9L  
 MOUNTED ON VERTICAL.



POWER TERMINATION BOX  
 0A-1241-4003  
 ASSY; POWER TERM BOX 120V-\*L



LIGHT DETECTOR  
 0A-1215-4001  
 ASSY; LIGHT DETECTOR-34MM



CONTROLLER BOARD  
 0A-1146-0067  
 CONTROLLER BOARD



FILTER  
 EN-1774  
 FILTER W/ WEATHERSTRIP

NOTES:

1. 10.64" FOR MODULE SIZE

DAKTRONICS, INC. BROOKINGS, SD 57006	
PROJ: GALAXY, LOVERED V1500 RGB 34MM	
TITLE: COMP. LAYOUT DIAGRAM; AF-3065-4864-34-RGB	
DES. BY: MMAMMENGA	DRAWN BY: JMMAMMENGA
APPR. BY:	DATE: 23MAY01
REVISION	
SCALE: NONE	1241-E10A-149477

REV.	01		
DATE	10SEP01		
DESCRIPTION	CORRECTED POWER SUPPLY LOCATION NOTE		
BY	BGB		
APPR.			

DENOTES POWER SUPPLY LOCATION.  
(I.E. PS303 IS LOCATED BEHIND A303.)

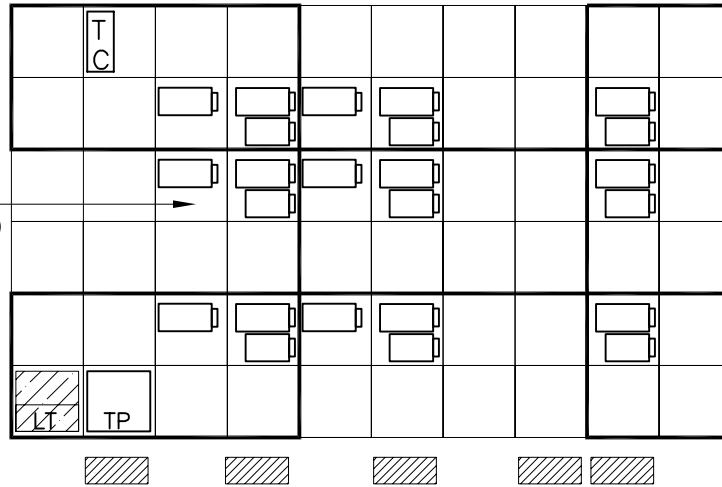

FRONT VIEW

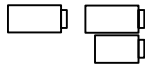

POWER SUPPLIES  
0A-1241-4001  
PS ASSY, 2, A-1633; 1, A-1591 RGB



POWER TERMINATION BOX  
0A-1241-4003  
ASSY; POWER TERM BOX 120V-\*L

B  
FAN  
0A-1213-4010  
B-1019 W/HARDWARE



LIGHT DETECTOR  
0A-1215-4001  
ASSY; LIGHT DETECTOR-34MM



FILTER  
EN-1774  
FILTER W/ WEATHERSTRIP



THERMOSTAT  
0A-1213-4024  
ENCLOSURE; THERMOSTAT 85-70-9L  
MOUNTED ON VERTICAL.



CONTROLLER BOARD  
0A-1146-0067  
CONTROLLER BOARD



POWER SUPPLIES  
0A-1213-4034  
PS ASSY, (1, A-1591, 1, A-1633)

NOTES:

- 10.64" FOR MODULE SIZE

DAKTRONICS, INC. BROOKINGS, SD 57006	
PROJ: GALAXY, LOUVERED V1500 RGB 34MM	
TITLE: COMP. LAYOUT DIAGRAM; AF-3065-4880-34-RGB	
DES. BY: MMAMMENGA	DRAWN BY: JMMAMMENGA
APPR. BY: NONE	DATE: 23MAY01
SCALE: NONE	1241-E10A-149479

REV.	01	10SEP01	CORRECTED POWER SUPPLY LOCATION NOTE	BY	BGB	APPR.
DATE			DESCRIPTION			

DENOTES POWER SUPPLY LOCATION.  
(I.E. PS303 IS LOCATED BEHIND A303.)

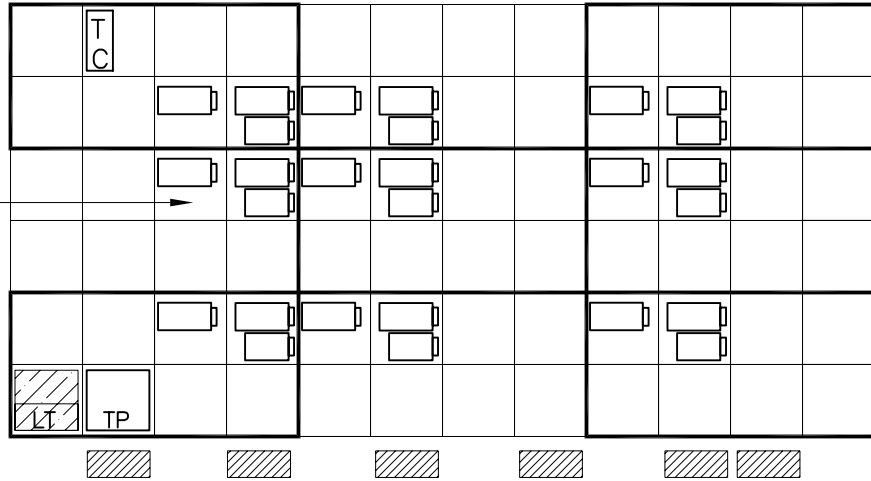

FRONT VIEW

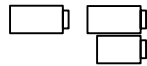

POWER SUPPLIES  
0A-1241-4001  
PS ASSY, 2, A-1633; 1, A-1591 RGB

B

FAN  
0A-1213-4010  
B-1019 W/HARDWARE



THERMOSTAT  
0A-1213-4024  
ENCLOSURE; THERMOSTAT 85-70-9L  
MOUNTED ON VERTICAL.



POWER TERMINATION BOX  
0A-1241-4003  
ASSY; POWER TERM BOX 120V-\*L



LIGHT DETECTOR  
0A-1215-4001  
ASSY; LIGHT DETECTOR-34MM



CONTROLLER BOARD  
0A-1146-0067  
CONTROLLER BOARD



FILTER  
EN-1774  
FILTER W/ WEATHERSTRIP

NOTES:

1. 10.64" FOR MODULE SIZE

DAKTRONICS, INC. BROOKINGS, SD 57006	
PROJ: GALAXY, LOVERED V1500 RGB 34MM	
TITLE: COMP. LAYOUT DIAGRAM; AF-3065-4896-34-RGB	
DES. BY: MMAMMENGA	DRAWN BY: JMMAMMENGA
DATE: 23MAY01	
REVISION	APPR. BY:
SCALE: NONE	1241-E10A-149480

REV.	01
DATE	10SEP01
DESCRIPTION	CORRECTED POWER SUPPLY LOCATION NOTE
BY	BGB
APPR.	

DENOTES POWER SUPPLY LOCATION.  
(I.E. PS303 IS LOCATED BEHIND A303.)

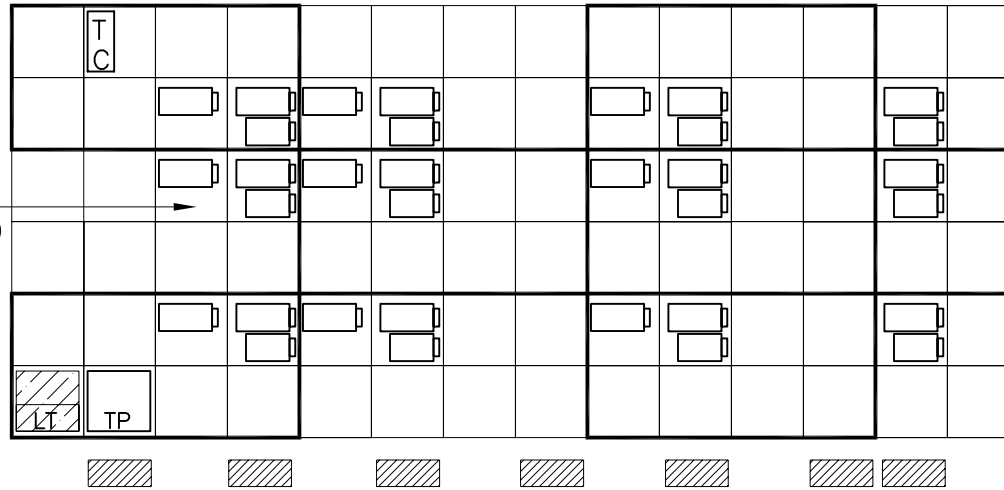

FRONT VIEW

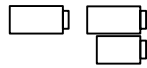

POWER SUPPLIES  
0A-1241-4001  
PS ASSY, 2, A-1633; 1, A-1591 RGB



POWER TERMINATION BOX  
0A-1241-4003  
ASSY; POWER TERM BOX 120V-\*L

B

FAN  
0A-1213-4010  
B-1019 W/HARDWARE



LIGHT DETECTOR  
0A-1215-4001  
ASSY; LIGHT DETECTOR-34MM



FILTER  
EN-1774  
FILTER W/ WEATHERSTRIP



THERMOSTAT  
0A-1213-4024  
ENCLOSURE; THERMOSTAT 85-70-9L  
MOUNTED ON VERTICAL.



CONTROLLER BOARD  
0A-1146-0067  
CONTROLLER BOARD



POWER SUPPLIES  
0A-1213-4034  
PS ASSY, (1, A-1591, 1, A-1633)

NOTES:

1. 10.64" FOR MODULE SIZE

PROJ:	GALAXY, LOUVERED V1500 RGB 34MM	
TITLE:	COMP. LAYOUT DIAGRAM; AF-3065-48112-34-RGB	
DES. BY:	MAMMENGA	DRAWN BY: JAMMENGA
DATE:	23MAY01	
REVISION	APPR. BY:	SCALE:
	NONE	NONE
	1241-E10A-149482	
	DAKTRONICS, INC. BROOKINGS, SD 57006	



REV.	01
DATE	10SEP01
DESCRIPTION	CORRECTED POWER SUPPLY LOCATION NOTE
BY	BGB
APPR.	

DENOTES POWER SUPPLY LOCATION.  
(I.E. PS303 IS LOCATED BEHIND A303.)

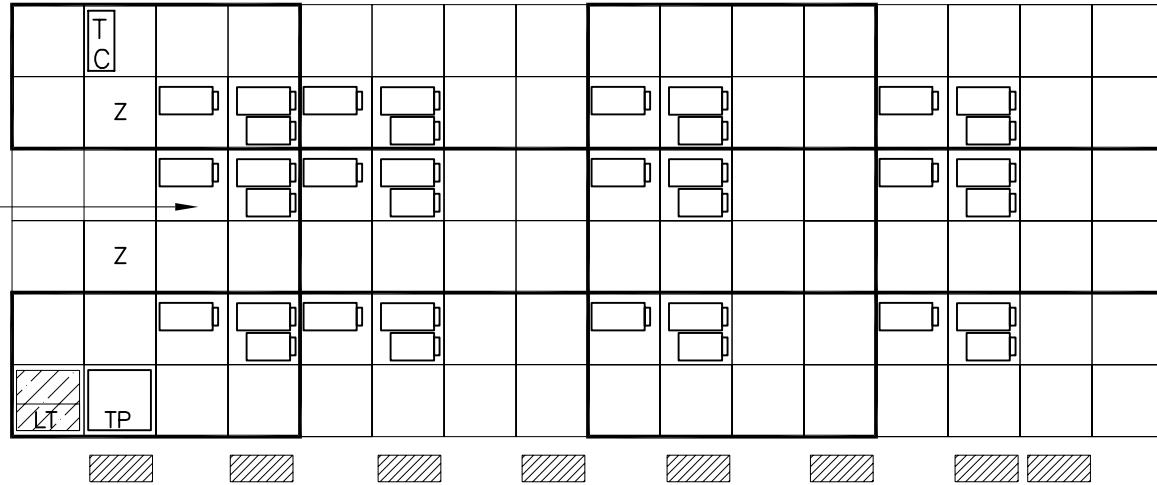

FRONT VIEW

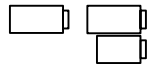

POWER SUPPLIES  
0A-1241-4001  
PS ASSY, 2, A-1633; 1, A-1591 RGB



POWER TERMINATION BOX  
0A-1241-4003  
ASSY; POWER TERM BOX 120V-\*L

B  
FAN

0A-1213-4010  
B-1019 W/HARDWARE



LIGHT DETECTOR  
0A-1215-4001  
ASSY; LIGHT DETECTOR-34MM



FILTER  
EN-1774  
FILTER W/ WEATHERSTRIP



THERMOSTAT  
0A-1213-4024  
ENCLOSURE; THERMOSTAT 85-70-9L  
MOUNTED ON VERTICAL.



CONTROLLER BOARD  
0A-1146-0067  
CONTROLLER BOARD

Z

LINE FILTER  
0A-1241-4002  
Z-FILTER ASSY. 2 W/GND BAR

NOTES:

1. 10.64" FOR MODULE SIZE

DAKTRONICS, INC. BROOKINGS, SD 57006	
PROJ: GALAXY, LOVERED V1500 RGB 34MM	
TITLE: COMP. LAYOUT DIAGRAM: AF-3065-48128-34-RGB	
DES. BY: MMAMMENGA	DRAWN BY: JMMAMMENGA
APPR. BY: NONE	DATE: 23MAY01
SCALE: NONE	1241-E10A-149483

REV.	01
DATE	10SEP01
DESCRIPTION	CORRECTED POWER SUPPLY LOCATION NOTE
BY	BGB
APPR.	

DENOTES POWER SUPPLY LOCATION.  
(I.E. PS303 IS LOCATED BEHIND A303.)

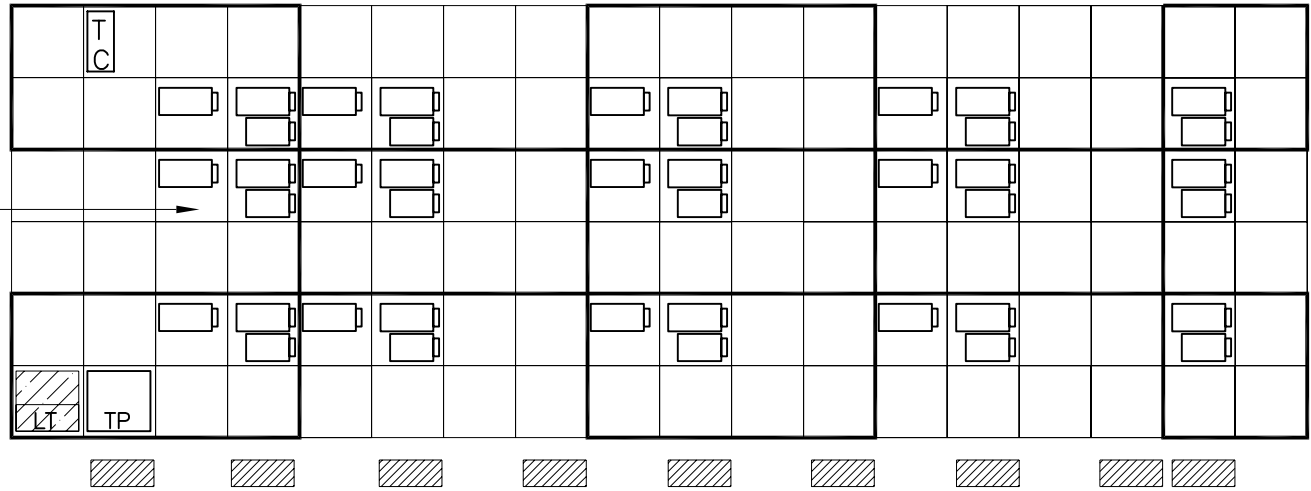

FRONT VIEW

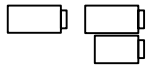

POWER SUPPLIES  
0A-1241-4001  
PS ASSY, 2, A-1633; 1, A-1591 RGB



POWER TERMINATION BOX  
0A-1241-4003  
ASSY; POWER TERM BOX 120V-\*L

B  
FAN  
0A-1213-4010  
B-1019 W/HARDWARE



LIGHT DETECTOR  
0A-1215-4001  
ASSY; LIGHT DETECTOR-34MM



FILTER  
EN-1774  
FILTER W/ WEATHERSTRIP



THERMOSTAT  
0A-1213-4024  
ENCLOSURE; THERMOSTAT 85-70-9L  
MOUNTED ON VERTICAL.



CONTROLLER BOARD  
0A-1146-0067  
CONTROLLER BOARD



POWER SUPPLIES  
0A-1213-4034  
PS ASSY, (1, A-1591, 1, A-1633)

NOTES:

- 10.64" FOR MODULE SIZE

PROJ:	GALAXY, LOVERED V1500 RGB 34MM	
TITLE:	COMP. LAYOUT DIAGRAM; AF-3065-48144-34-RGB	
DES. BY:	MAMMENGA	DRAWN BY: JMMAMMENGA
DATE:	23MAY01	
REVISION	APPR. BY:	1241-E10A-149484
SCALE:	NONE	
		DAKTRONICS, INC. BROOKINGS, SD 57006



REV.	01
DATE	14SEP01
DESCRIPTION	UPDATED POWER TERM BOX
BY	BGB
APPR.	

PROJ.	GALAXY, LOUVERED V1500 RGB 34MM	
TITLE	F. ASSY, AF-3065-8**-RGB-34	
DES. BY:	MAMMENGA	DRAWN BY: JAMMENGA
REVISION	APPR. BY:	DATE: 05JUNE01
SCALE:	1=25	
DAKTRONICS, INC. BROOKINGS, SD 57006		
1241-E10A-149939		

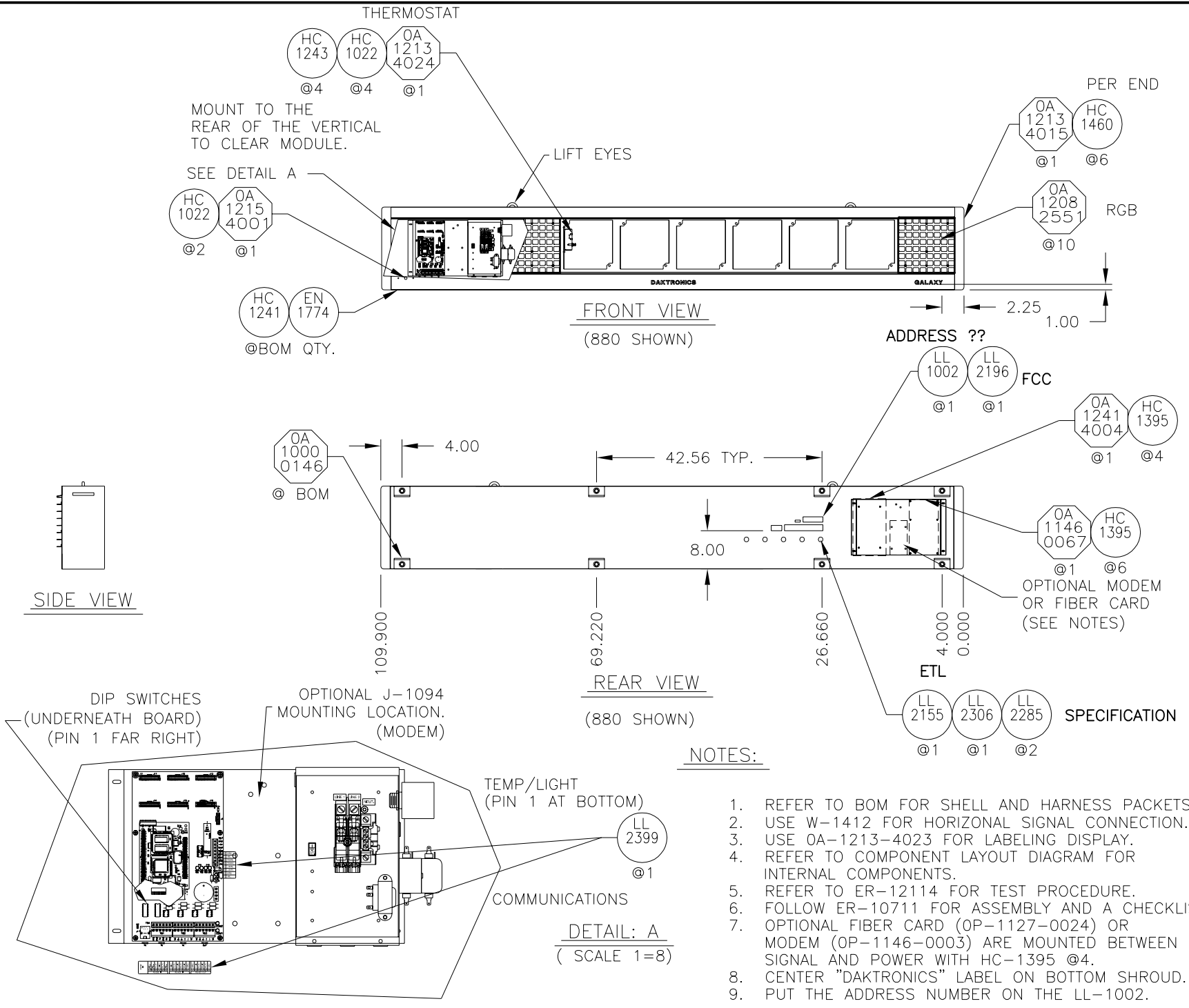

- NOTES:**
1. REFER TO BOM FOR SHELL AND HARNESS PACKETS.
  2. USE W-1412 FOR HORIZONTAL SIGNAL CONNECTION.
  3. USE OA-1213-4023 FOR LABELING DISPLAY.
  4. REFER TO COMPONENT LAYOUT DIAGRAM FOR INTERNAL COMPONENTS.
  5. REFER TO ER-12114 FOR TEST PROCEDURE.
  6. FOLLOW ER-10711 FOR ASSEMBLY AND A CHECKLIST.
  7. OPTIONAL FIBER CARD (OP-1127-0024) OR MODEM (OP-1146-0003) ARE MOUNTED BETWEEN SIGNAL AND POWER WITH HC-1395 @4.
  8. CENTER "DAKTRONICS" LABEL ON BOTTOM SHROUD.
  9. PUT THE ADDRESS NUMBER ON THE LL-1002.

REV.	01
DATE	14SEP01
DESCRIPTION	UPDATED POWER TERM. BOX.
BY	BGB
APPR.	

PROJ.	GALAXY, LOUVERED V1500 RGB 34MM	
TITLE	F. ASSY, AF-3065-16**-RGB-34	
DES. BY:	MMAMMENGA	
DRAWN BY:	JMMAMMENGA	
DATE:	05JUNE01	
REVISION	APPR. BY:	1241-E10A-149968
SCALE:	1=25	

DAKTRONICS, INC. BROOKINGS, SD 57006

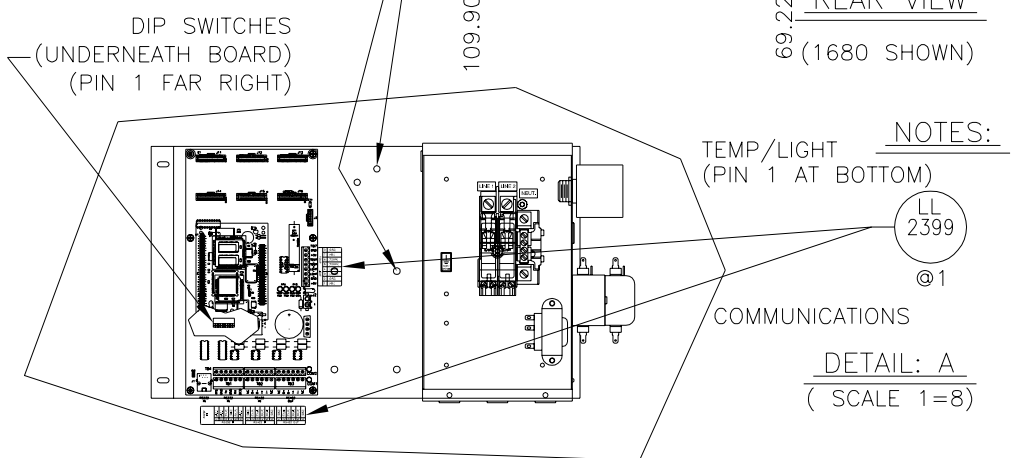
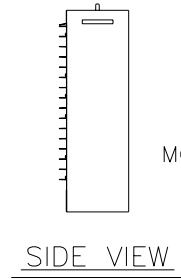
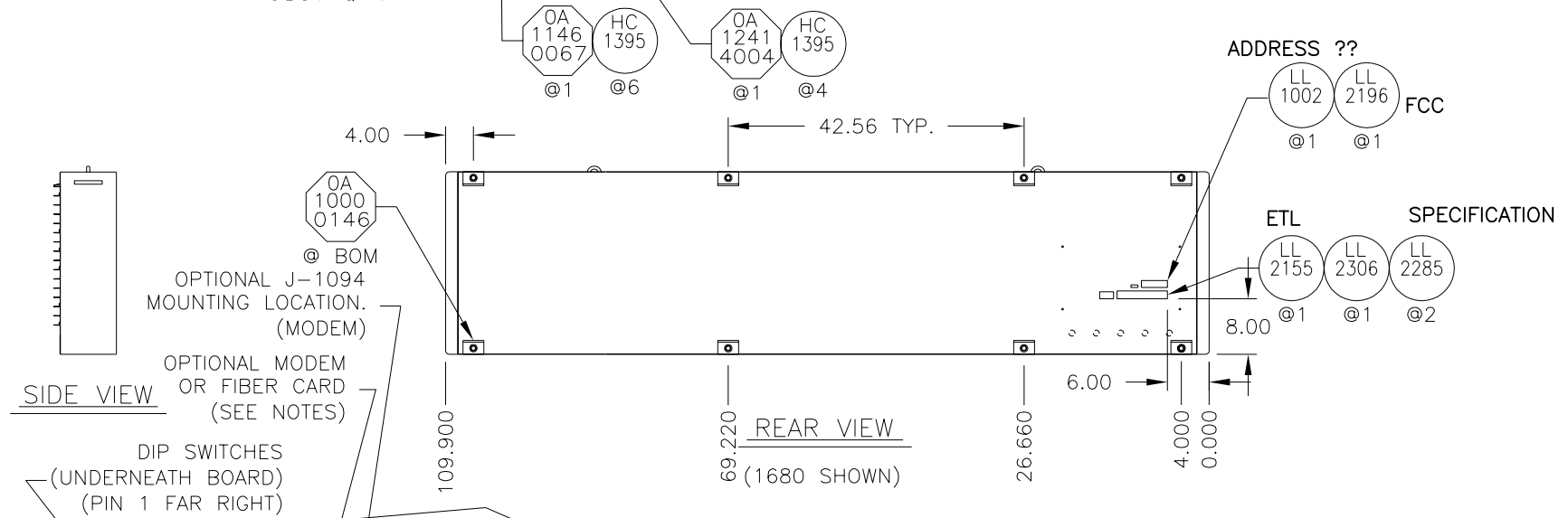
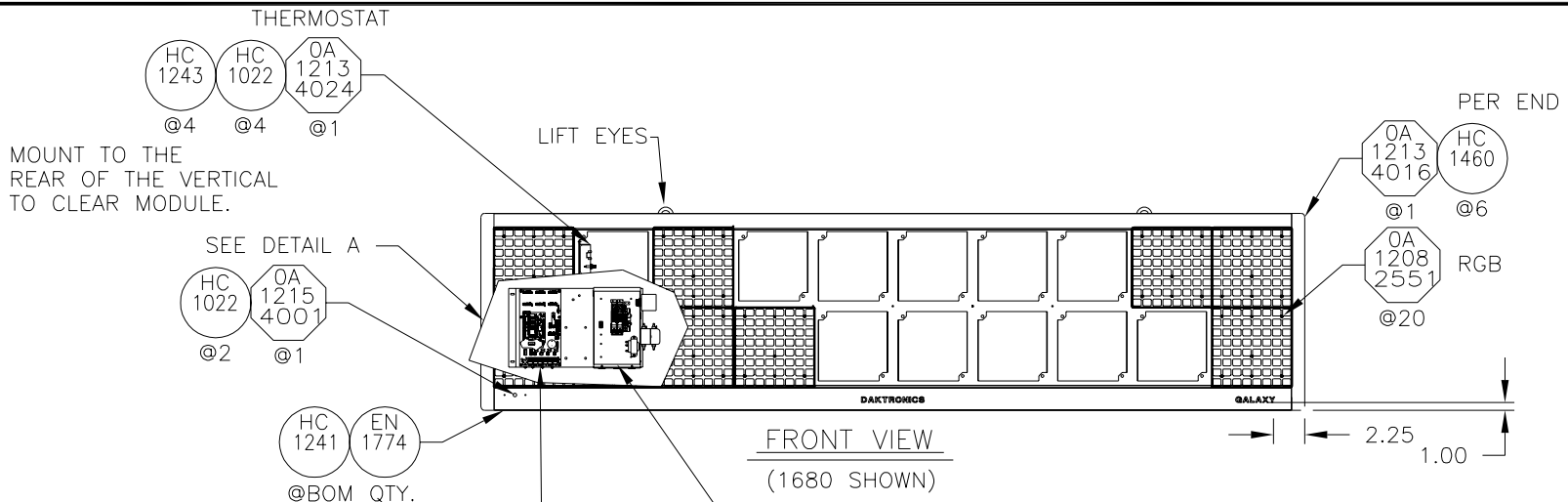

**NOTES:**

1. REFER TO BOM FOR SHELL AND HARNESS PACKETS.
2. USE W-1412 FOR HORIZONTAL SIGNAL CONNECTION.
3. USE OA-1213-4023 FOR LABELING DISPLAY.
4. REFER TO COMPONENT LAYOUT DIAGRAM FOR INTERNAL COMPONENTS.
5. REFER TO ER-12114 FOR TEST PROCEDURE.
6. FOLLOW ER-10711 FOR ASSEMBLY AND A CHECKLIST.
7. OPTIONAL FIBER CARD (OP-1127-0024) OR MODEM (OP-1146-0003) ARE MOUNTED BETWEEN SIGNAL AND POWER WITH HC-1395 @4.
8. CENTER "DAKTRONICS" LABEL ON BOTTOM SHROUD.
9. PUT THE ADDRESS NUMBER ON THE LL-1002.

REV.	01			
DATE	17SEP01			
DESCRIPTION	UPDATED POWER TERM BOX AND MFG PLATE			
BY	BGB			
APPR.				

DAKTRONICS, INC. BROOKINGS, SD 57006	
PROJ:	GALAXY, LOUVERED V1500 RGB 34MM
TITLE:	F.A.S.S.Y., AF-3065-40***-RGB-34
DES. BY:	MMAMMENGA
APPR. BY:	MMAMMENGA
DATE:	26JUN01
REVISION	
SCALE:	1=30
1241-E10A-150660	

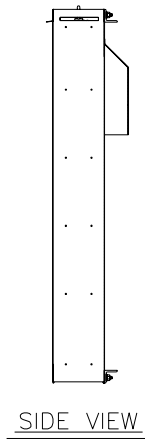
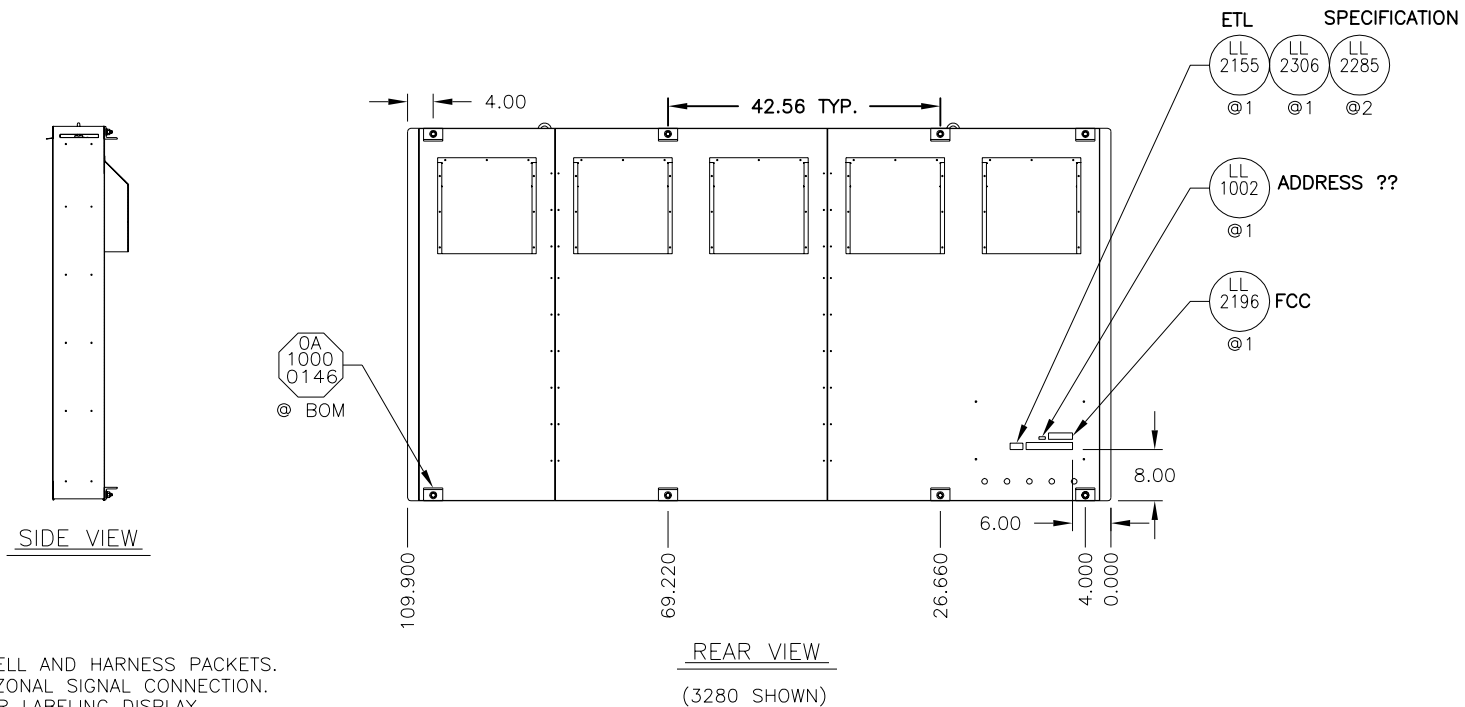
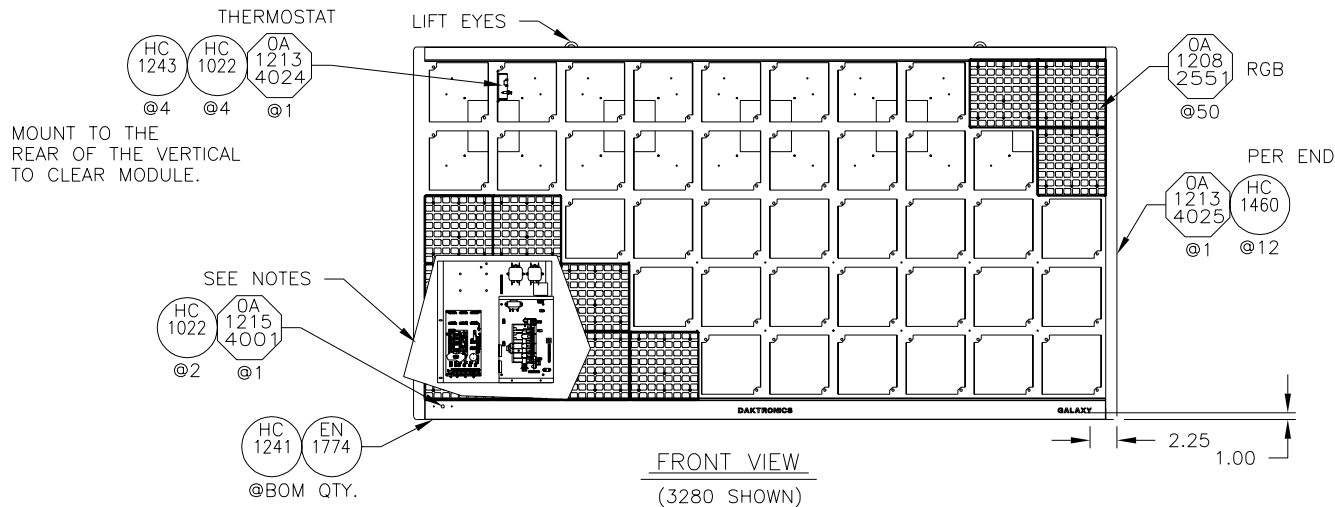

NOTES:

1. REFER TO BOM FOR SHELL AND HARNESS PACKETS.
2. USE W-1412 FOR HORIZONTAL SIGNAL CONNECTION.
3. USE OA-1213-4023 FOR LABELING DISPLAY.
4. REFER TO COMPONENT LAYOUT DIAGRAM FOR INTERNAL COMPONENTS.
5. REFER TO ER-12114 FOR TEST PROCEDURE.
6. FOLLOW ER-10711 FOR ASSEMBLY AND A CHECKLIST.
7. SEE DWG-00156086 FOR DETAIL OF CONTROLLER AND POWER TERM BOX.
8. CENTER "DAKTRONICS" LABEL ON BOTTOM SHROUD.
9. PUT THE ADDRESS NUMBER ON THE LL-1002.



HOOK UP THE WIRES FROM THE SURGE ARRESTER DURING PRODUCT INSTALLATION ACCORDING TO THIS DIAGRAM:

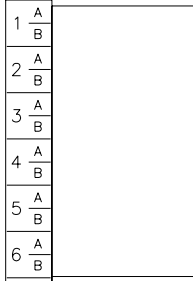
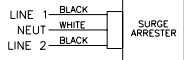

0

0

FRONT VIEW  
(COVER)

ALL ELECTRICAL WORK (INCLUDING GROUNDING) MUST BE DONE ACCORDING TO LOCAL AREA AND THE NATIONAL ELECTRICAL CODES.

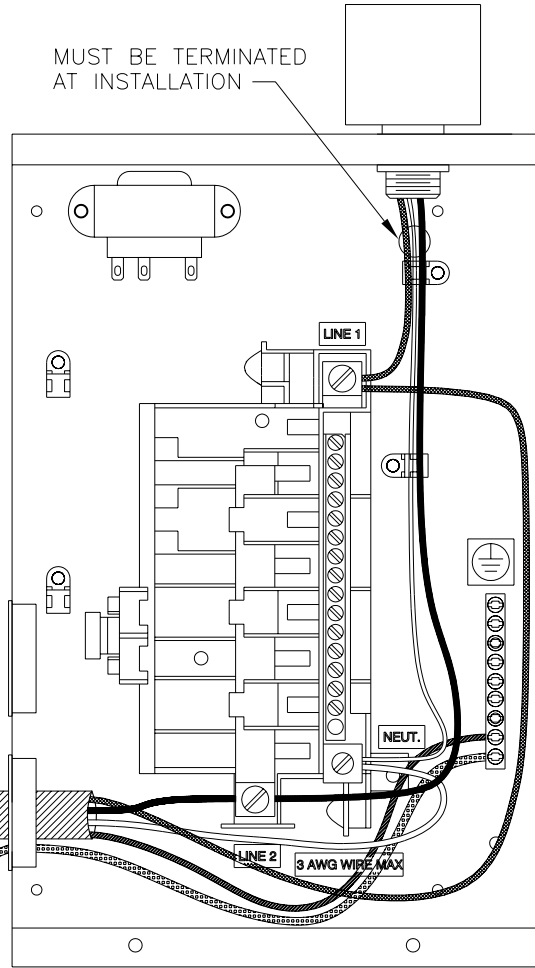

LINE 1  
LINE 2  
NEUTRAL  
GROUND

TO DISPLAY GROUND ELECTRODE

NOTE 1: IF DISPLAY IS POWERED WITH 120VAC SINGLE PHASE (TWO WIRE + GND), INSTALL A JUMPER BETWEEN LUG(LINE 1) AND LUG(LINE 2). SIZE JUMPER PER NEC.

DAKTRONICS, INC. BROOKINGS, SD 57006			
PROJ: GALAXY, LOUVERED V1500 RGB 34MM			
TITLE: POWER CONNECTION, AF-306X			
DES. BY:	DRAWN BY: DMATHERN	DATE: 22AUG01	
REVISION	APPR. BY:	1241-R01A-154965	
	SCALE: NONE		

REV.	DATE	DESCRIPTION	BY	APPR.



REV.	DATE	DESCRIPTION	BY	APPR.
02	09 OCT 01	REMOVED HC-1021 ADDED HC-1012 PER ECO 31094	MJM	MDM
01	12SEP01	MOVED TRANSFORMER IN FROM EDGE OF BOX 0.1"	MDM	MDM

DAKTRONICS, INC. BROOKINGS, SD 57006	
PROJ.:	GALAXY, LOUVERED V1500 RGB 34MM
TITLE:	ASSY, POWER BOX 2 POSITION
DES. BY:	MAMMANGA
DRAWN BY:	BBENNING
DATE:	07SEP01
REVISION	APPR. BY:
SCALE:	1 = 4
1241E10A-155736	

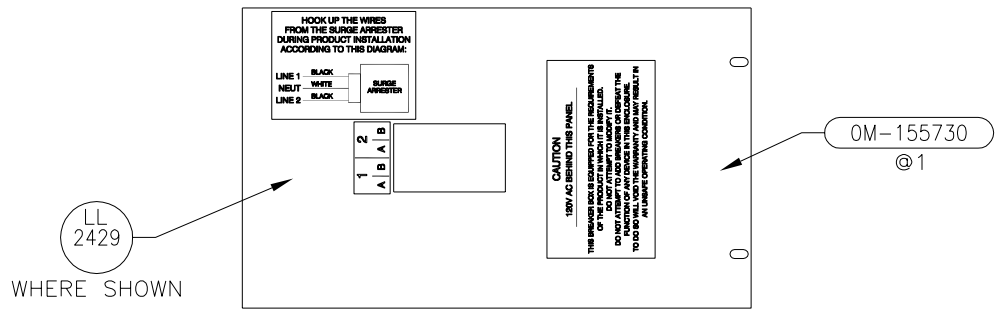

COVER

SILICONE FOR WATER PROOFING

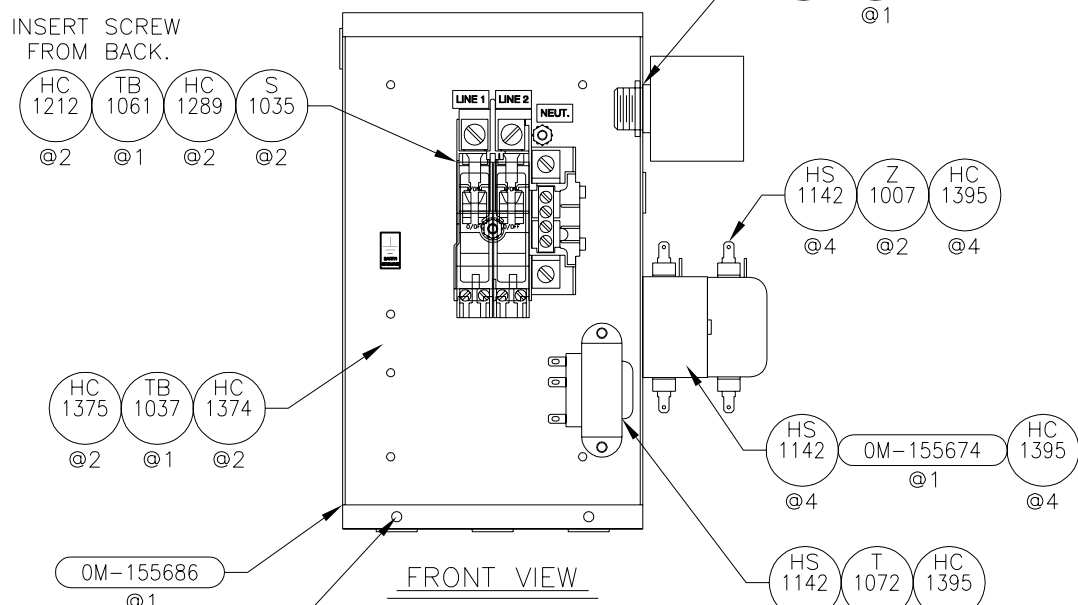

FRONT VIEW

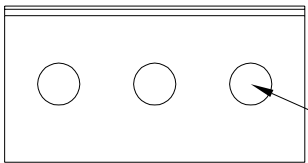

BOTTOM VIEW

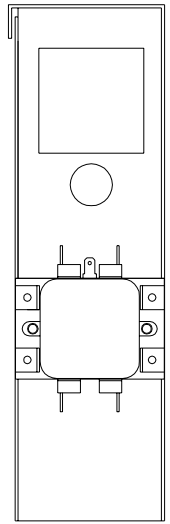

SIDE VIEW

NOTES:

1. FROM THE FRONT VIEW AS SHOWN, Z1 IS THE LEFT FILTER, (Z-1007).
2. GROUND TERMINAL IS UP ON Z-1007.

REV.	DATE	DESCRIPTION	BY	APPR.
02	30MAY03	ADDED OA-1146-0035	KSM	
01	26SEP02	REMOVED HS-1164 AND HS-1219 PER HARDWARE CHANGE.	MLS	

DAKTRONICS, INC. BROOKINGS, SD 57006	
PROJ.:	GALAXY, LOUVERED V1500 RGB 34MM
TITLE:	DETAIL, CONTROLLER AND POWER TERM BOX 24-48 HIGH
DES. BY:	MMAMMNGA
DRAWN BY:	BBENNING
DATE:	17SEP2001
REVISION	APPR. BY:
SCALE:	1 = 4
1241-E10A-156086	

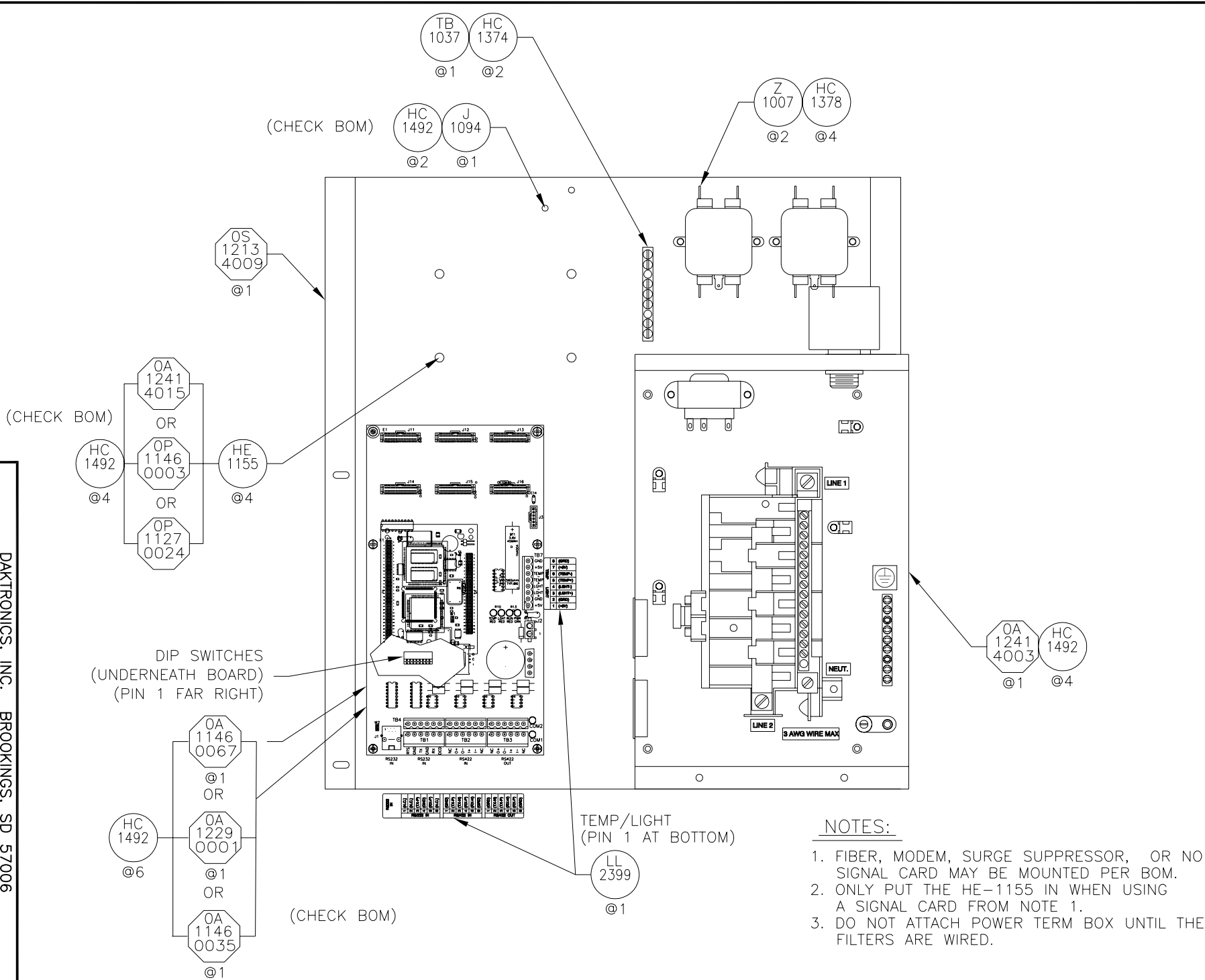

PLASTIC HOUSING WITH WEATHERSTRIPPING FOR WATERPROOFING

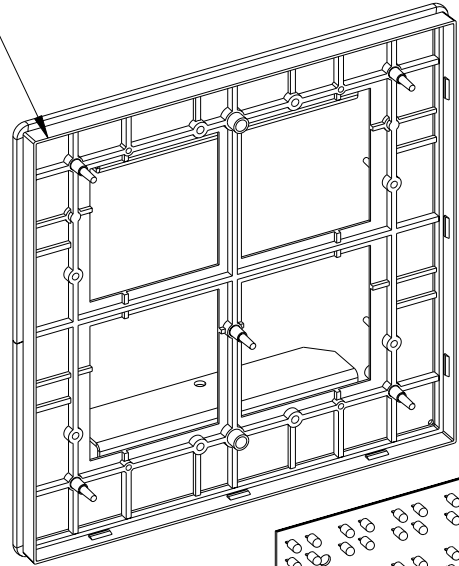

SINGLE LED AND DRIVER PANEL

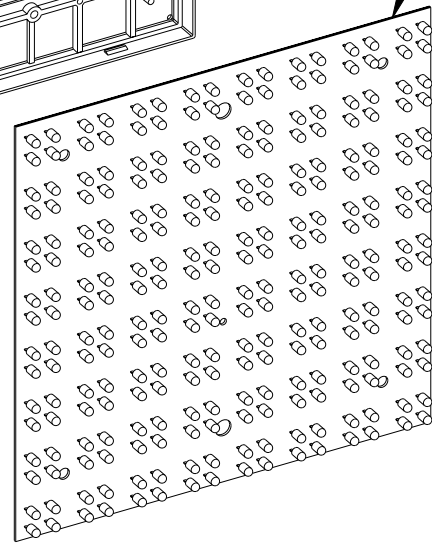

LOUVER

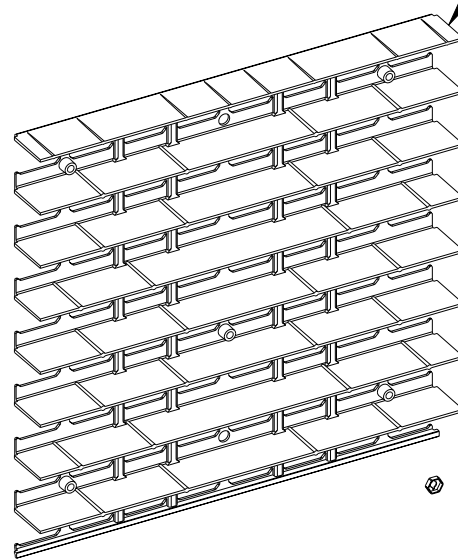

LATCH ACCESS PLUG @2 FOR FRONT AND REAR MODULE ACCESS AND WATERPROOFING



TWIST ON FASTENERS @5 FOR ATTACHMENT OF LOUVER



DAKTRONICS, INC. BROOKINGS, SD 57006	
PROJ:	34MM OUTDOOR GALAXY
TITLE:	EXPLODED FRONT VIEW; SINGLE PANEL MODULE
DES. BY:	NANDAL
DRAWN BY:	DNUGTEREN
DATE:	10JAN00
REVISION	SHEET 1 OF DWG 126111
SCALE:	1=2
1208-E10B-126111	

REV.	DATE	DESCRIPTION	BY	APPR.

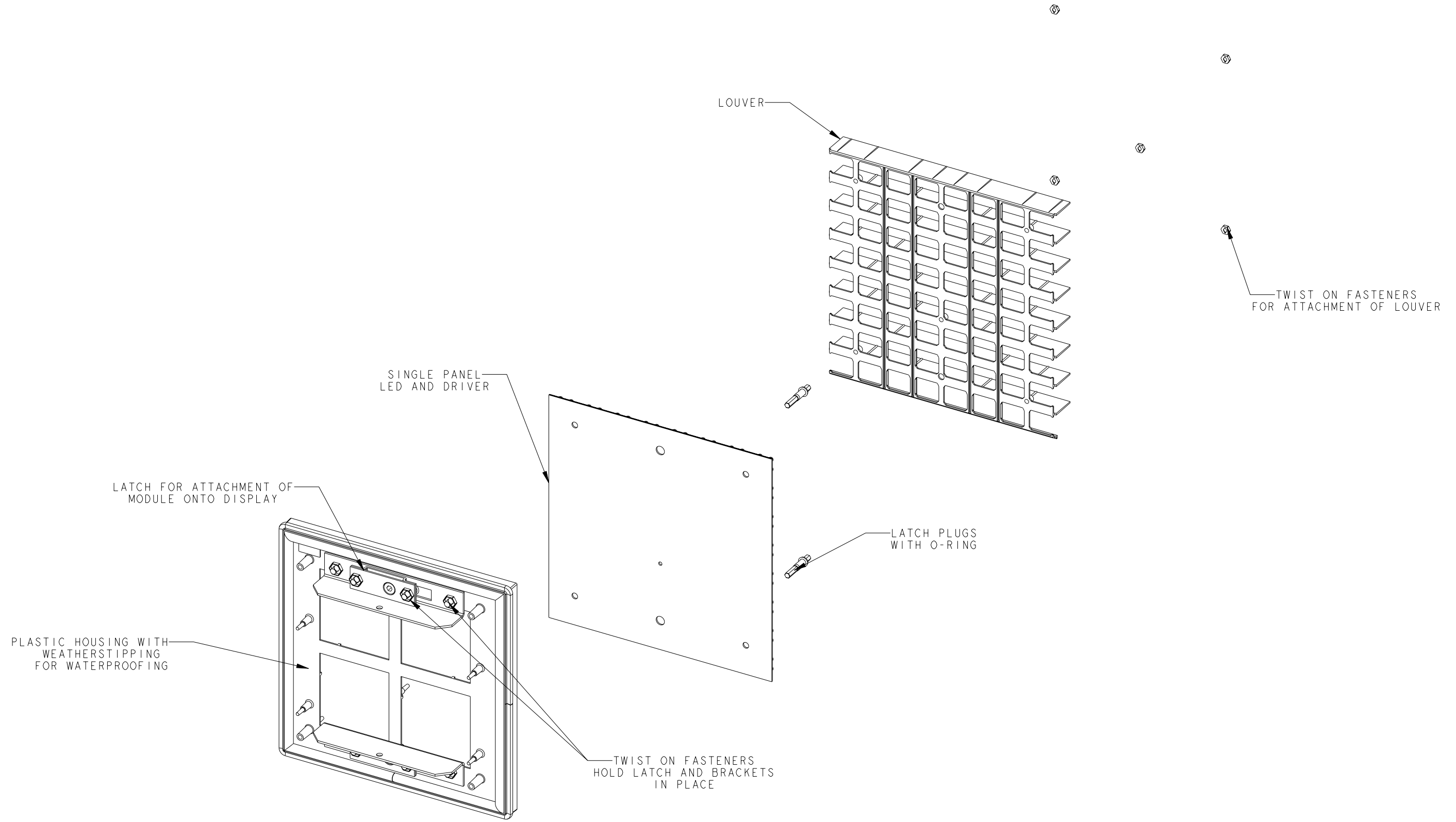

DAKTRONICS, INC. BROOKINGS, SD 57006	
PROJ:	34MM OUTDOOR GALAXY
TITLE:	EXPLODED REAR VIEW; SINGLE PANEL MODULE
DES. BY:	NANDAL
DRAWN BY:	DNUGTEREN
DATE:	10JAN00
REVISION	SHEET 1 OF DWG 126112
SCALE:	1=2
1208 - E10B - 126112	

REV.	DATE	DESCRIPTION	BY	APPR.

SIZES AND (APPROX.) WEIGHTS FOR 34 mm DISPLAYS  
AX-XXXX-8/32XX-34B

SIZE	TOTAL DISPLAY		ACTIVE AREA		CLIP DISTANCE HHH	(APPROX.) WEIGHT
	H	L	HH	LL		
8X48	15.64	67.34	10.64	63.84	11.64	80 lbs
8X64	15.64	88.62	10.64	85.12	11.64	100 lbs
8X80	15.64	109.90	10.64	106.40	11.64	120 lbs
8X96	15.64	131.18	10.64	127.68	11.64	150 lbs
8X112	15.64	152.46	10.64	148.96	11.64	170 lbs
8X128	15.64	173.74	10.64	170.24	11.64	200 lbs
8X144	15.64	195.02	10.64	191.52	11.64	220 lbs
16X48	26.28	67.34	21.28	63.84	22.28	150 lbs
16X64	26.28	88.62	21.28	85.12	22.28	200 lbs
16X80	26.28	109.90	21.28	106.40	22.28	240 lbs
16X96	26.28	131.18	21.28	127.68	22.28	300 lbs
16X112	26.28	152.46	21.28	148.96	22.28	340 lbs
16X128	26.28	173.74	21.28	170.24	22.28	400 lbs
16X144	26.28	195.02	21.28	191.52	22.28	440 lbs
24X48	36.92	67.34	31.92	63.84	32.92	220 lbs
24X64	36.92	88.62	31.92	85.12	32.92	300 lbs
24X80	36.92	109.90	31.92	106.40	32.92	370 lbs
24X96	36.92	131.18	31.92	127.68	32.92	440 lbs
24X112	36.92	152.46	31.92	148.96	32.92	510 lbs
24X128	36.92	173.74	31.92	170.24	32.92	580 lbs
24X144	36.92	195.02	31.92	191.52	32.92	650 lbs
32X48	36.92	67.34	42.56	63.84	32.92	300 lbs
32X64	47.56	88.62	42.56	85.12	43.56	400 lbs
32X80	47.56	109.90	42.56	106.40	43.56	490 lbs
32X96	47.56	131.18	42.56	127.68	43.56	590 lbs
32X112	47.56	152.46	42.56	148.96	43.56	680 lbs
32X128	47.56	173.74	42.56	170.24	43.56	780 lbs
32X144	47.56	195.02	42.56	191.52	43.56	880 lbs

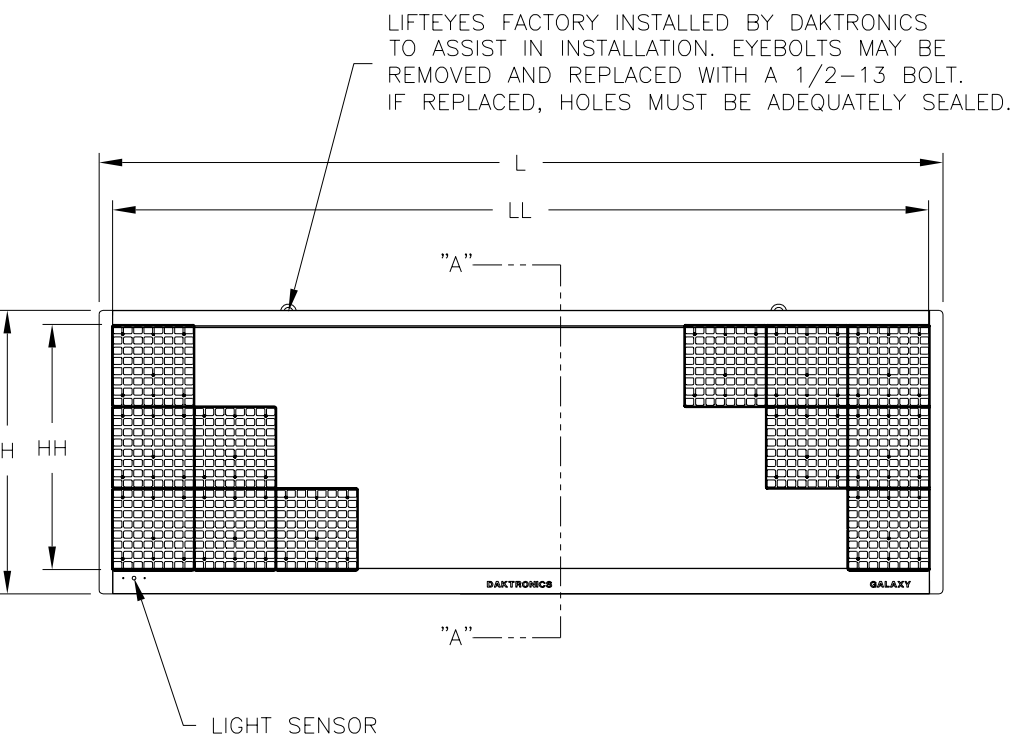
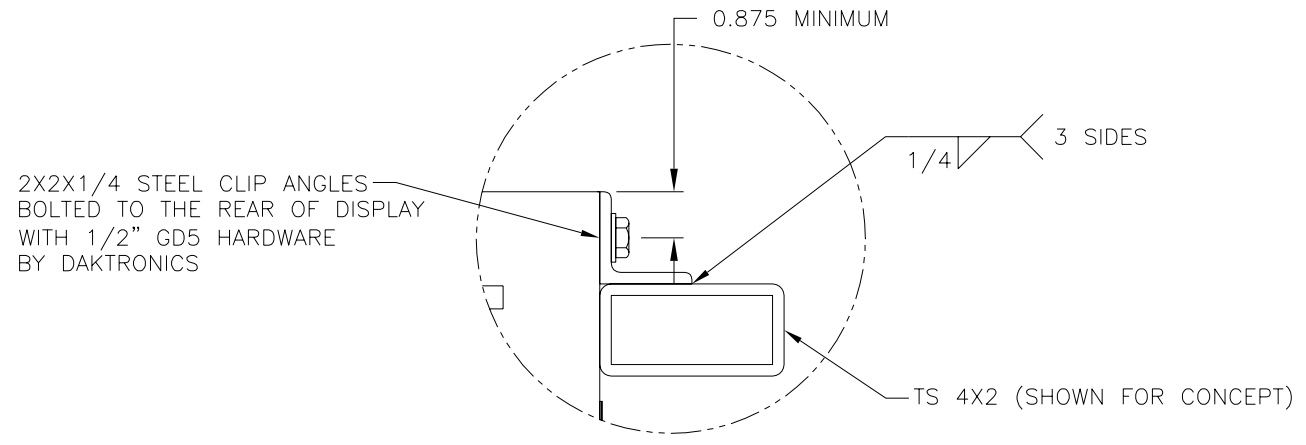

FRONT VIEW  
(24X80 SHOWN)

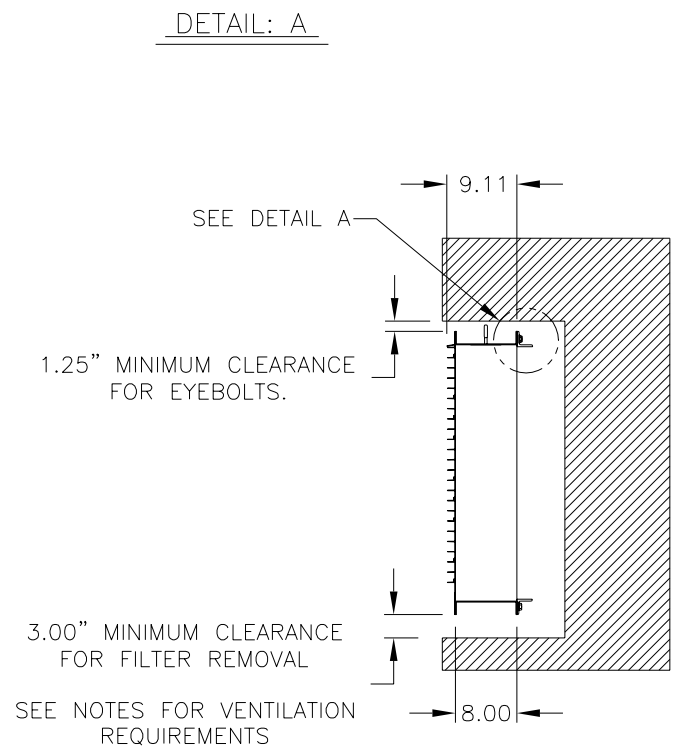

SECTION: A-A

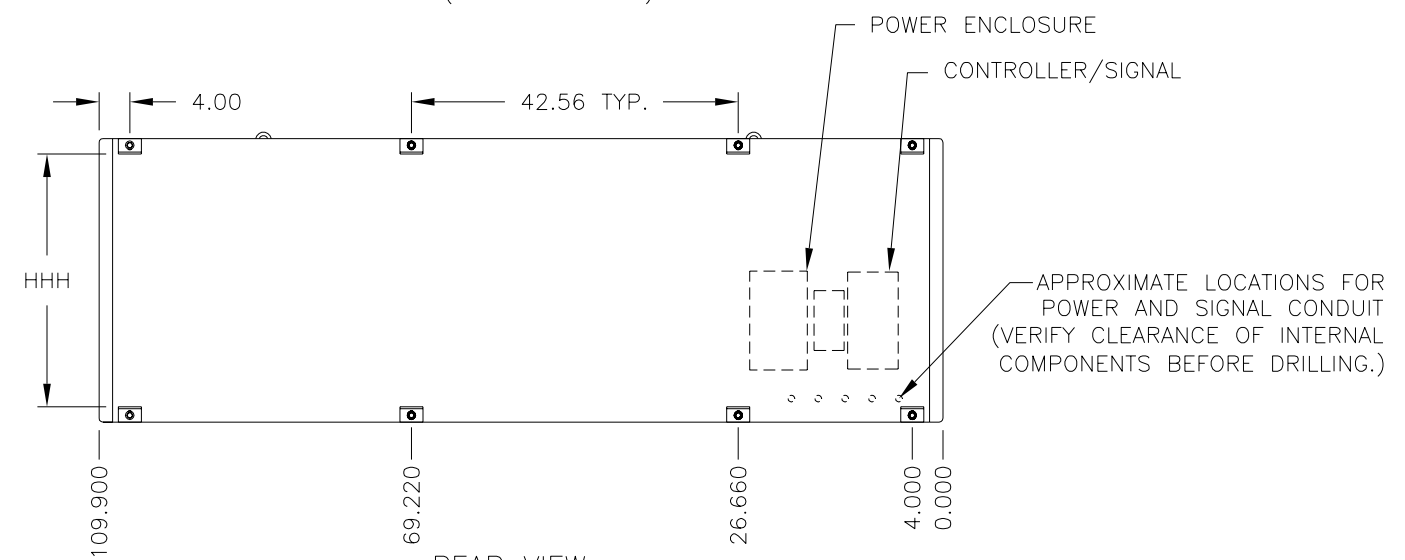

REAR VIEW

NOTES:

1. ALL DIMENSIONS ARE IN INCHES.
2. DISPLAY CABINET IS ALUMINUM.
3. DISPLAY CABINET COLOR IS FLAT BLACK.
4. FRONT ACCESS FOR SERVICE.
5. THE DISPLAY IS BOTTOM VENTILATED.
6. MINIMUM BOTTOM CLEARANCE IS 3.00".
7. MINIMUM TOP CLEARANCE IS 1.25".
7. MAIN ELECTRICAL DISCONNECT TO BE FURNISHED BY CUSTOMER.
8. FOR SIZES AND APPROX. WEIGHTS SEE ABOVE TABLE.
9. FOR POWER REQUIREMENTS REFER TO 1241-R01A-148571.
10. DAKTRONICS INC. IS NOT RESPONSIBLE FOR HARDWARE ATTACHING DISPLAY TO STRUCTURE.
11. REFER TO INSTALLATION ENGINEERING DOCUMENT FOR MOUNTING TEMPERATURE SENSOR. (ER-010711)
12. VENTILATION: IN ENCLOSED CABINET SITUATION, 6 SQUARE INCHES OF UNOBSTRUCTED OPENING PER MODULE MUST BE PROVIDED TO INSURE ADEQUATE DISPLAY COOLING. ALLOWANCES MUST BE MADE TO COMPENSATE FOR THE PERCENTAGE OF A MATERIAL COVERING THE OPENINGS IN THE STRUCTURE. FOR ADEQUATE COOLING, FORCED VENTILATION OF THE ENCLOSED STRUCTURE MAY BE REQUIRED. IF AIR MUST BE FORCED INTO THE ENCLOSED CABINET, 10 CUBIC FEET PER MINUTE MUST BE PROVIDED PER MODULE (10.6" X 10.6" ACTIVE AREA).
13. CUSTOMER IS RESPONSIBLE FOR THE STRUCTURAL INTEGRITY OF THE STRUCTURE THAT THE DISPLAY IS MOUNTED TO.
14. MAIN ELECTRICAL DISCONNECT TO BE FURNISHED BY CUSTOMER.

DAKTRONICS, INC. BROOKINGS, SD 57006

PROJ: GALAXY, LOUVERED V1500 RGB 34MM  
 TITLE: SHOP DWG; AF-3065-8/32XXX-34B  
 DES. BY: MMAMMENGA DRAWN BY: B BENNING DATE: 22AUG2001

REV.	DATE	DESCRIPTION	BY	APPR.

REVISION APPR. BY: 1241-E10B-148418  
 SCALE: 1 = 25

SIZES AND (APPROX.) WEIGHTS FOR 34 mm DISPLAYS  
AX-XXXX-40/48XX-34B.

SIZE	TOTAL DISPLAY		ACTIVE AREA		CLIP DISTANCE HHH	(APPROX.) WEIGHT
	H	L	HH	LL		
40X48	58.20	67.34	53.20	63.84	54.20	360 lbs
40X64	58.20	88.62	53.20	85.12	54.20	480 lbs
40X80	58.20	109.90	53.20	106.40	54.20	600 lbs
40X96	58.20	131.18	53.20	127.68	54.20	730 lbs
40X112	58.20	152.46	53.20	148.96	54.20	850 lbs
40X128	58.20	173.74	53.20	170.24	54.20	970 lbs
40X144	58.20	195.02	53.20	191.52	54.20	1100 lbs
48X48	68.84	67.34	63.84	63.84	64.84	440 lbs
48X64	68.84	88.62	63.84	85.12	64.84	580 lbs
48X80	68.84	109.90	63.84	106.40	64.84	730 lbs
48X96	68.84	131.18	63.84	127.68	64.84	870 lbs
48X112	68.84	152.46	63.84	148.96	64.84	1020 lbs
48X128	68.84	173.74	63.84	170.24	64.84	1170 lbs
48X144	68.84	195.02	63.84	191.52	64.84	1300 lbs

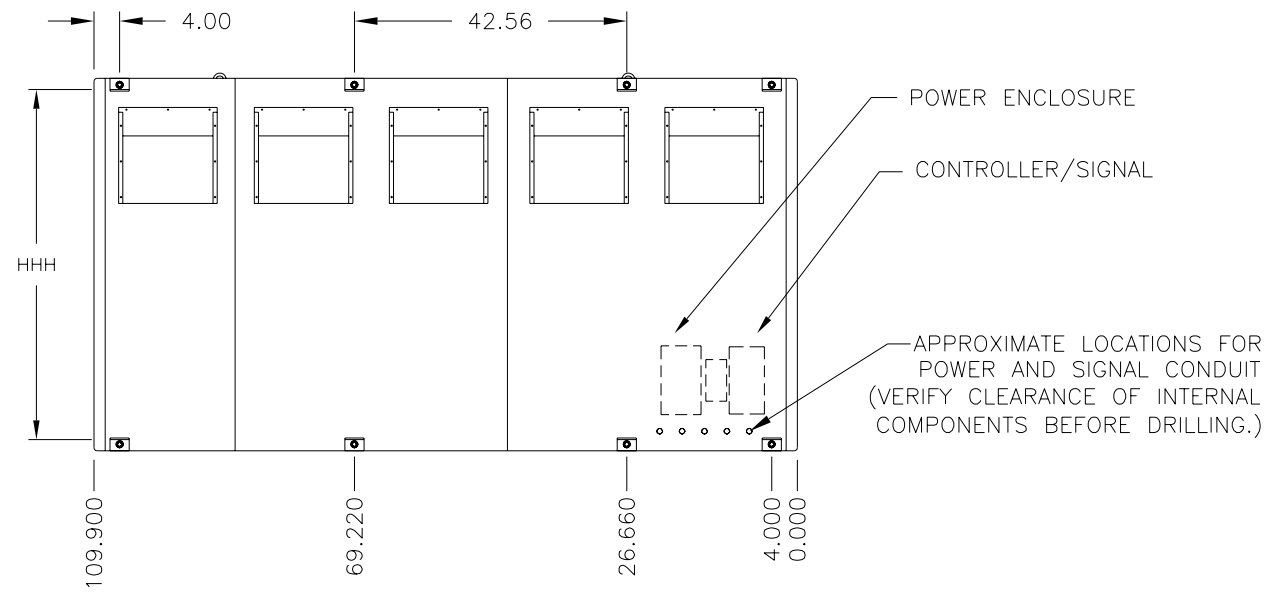

REAR VIEW

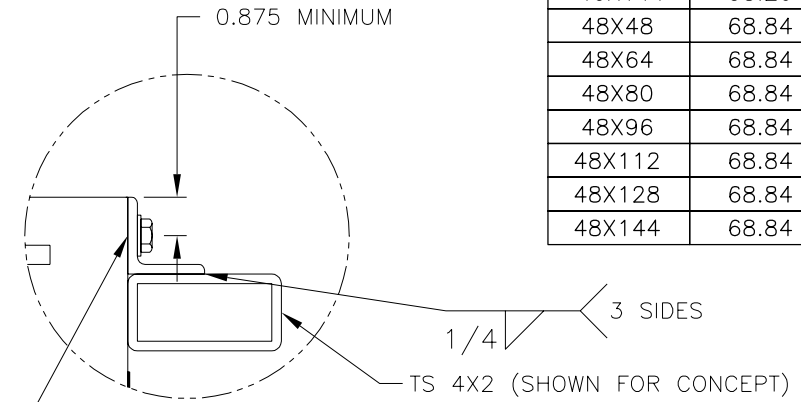

DETAIL: A

2X2X1/4 STEEL CLIP ANGLES  
BOLTED TO THE REAR OF DISPLAY  
WITH 1/2" GD5 HARDWARE  
BY DAKTRONICS

LIFTEYES FACTORY INSTALLED BY DAKTRONICS  
TO ASSIST IN INSTALLATION. EYEBOLTS MAY BE  
REMOVED AND REPLACED WITH A 1/2-13 BOLT  
IF REPLACED, HOLES MUST BE ADEQUATELY SEALED.

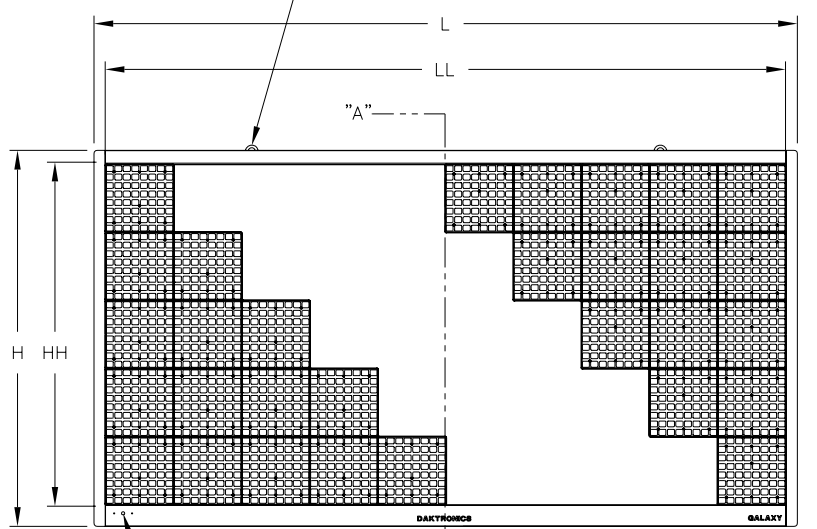

FRONT VIEW  
(40X80 SHOWN)

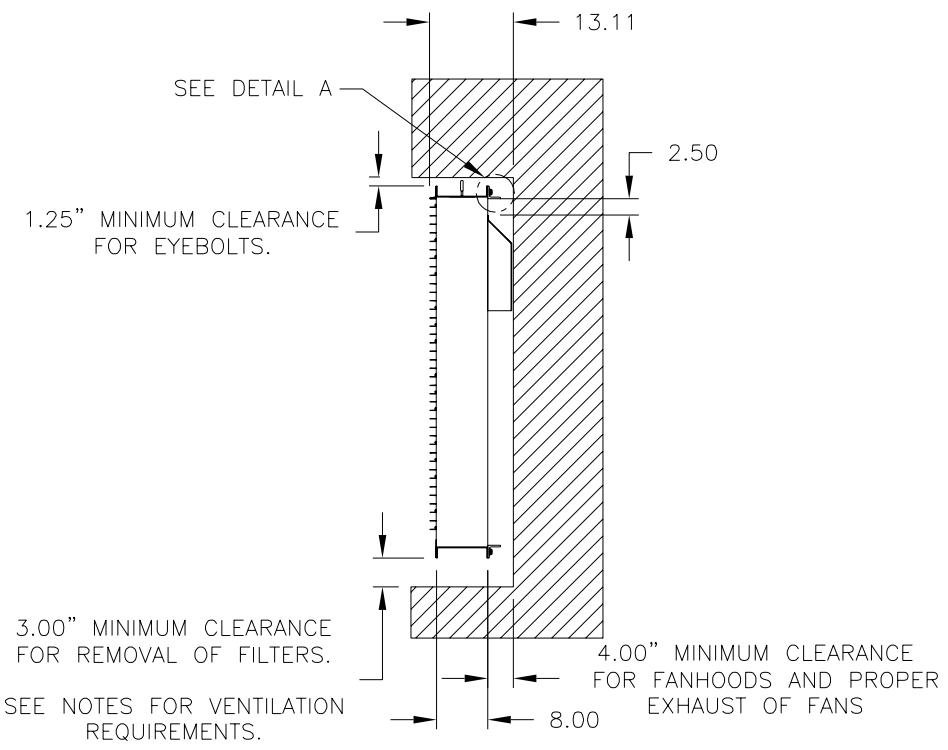

SECTION: A-A

NOTES:

1. ALL DIMENSIONS ARE IN INCHES.
2. DISPLAY CABINET IS ALUMINUM.
3. DISPLAY CABINET COLOR IS FLAT BLACK.
4. FRONT ACCESS FOR SERVICE.
5. THE DISPLAY IS BOTTOM VENTILATED.
6. MINIMUM BOTTOM CLEARANCE IS 3.00"
7. MINIMUM TOP CLEARANCE IS 1.25"
8. FOR SIZES AND APPROX. WEIGHTS SEE ABOVE TABLE.
9. FOR POWER REQUIREMENTS REFER TO 1241-R01A-148571.
10. DAKTRONICS INC. IS NOT RESPONSIBLE FOR HARDWARE ATTACHING DISPLAY TO STRUCTURE.
11. REFER TO INSTALLATION ENGINEERING DOCUMENT FOR MOUNTING TEMPERATURE SENSOR. (ER-010711)
12. VENTILATION: IN ENCLOSED CABINET SITUATION, 6 SQUARE INCHES OF UNOBSTRUCTED OPENING PER MODULE MUST BE PROVIDED TO INSURE ADEQUATE DISPLAY COOLING. ALLOWANCES MUST BE MADE TO COMPENSATE FOR THE PERCENTAGE OF A MATERIAL COVERING THE OPENINGS IN THE STRUCTURE. FOR ADEQUATE COOLING, FORCED VENTILATION OF THE ENCLOSED STRUCTURE MAY BE REQUIRED. IF AIR MUST BE FORCED INTO THE ENCLOSED CABINET, 10 CUBIC FEET PER MINUTE MUST BE PROVIDED PER MODULE (10.6" X 10.6" ACTIVE AREA).
13. CUSTOMER IS RESPONSIBLE FOR THE STRUCTURAL INTEGRITY OF THE STRUCTURE THAT THE DISPLAY IS MOUNTED TO.
14. MAIN ELECTRICAL DISCONNECT TO BE FURNISHED BY CUSTOMER.

DAKTRONICS, INC. BROOKINGS, SD 57006			
PROJ: GALAXY, LOUVERED V1500 RGB 34MM			
TITLE: SHOP DWG; AF-3065-40/48XXX-34B			
DES. BY: MMAMMENGA		DRAWN BY: B BENNING	
DATE: 24AUG2001		DATE: 24AUG2001	
REVISION	APPR. BY:	1241-E10B-148419	
SCALE: 1 = 30			

REV.	DATE	DESCRIPTION	BY	APPR.

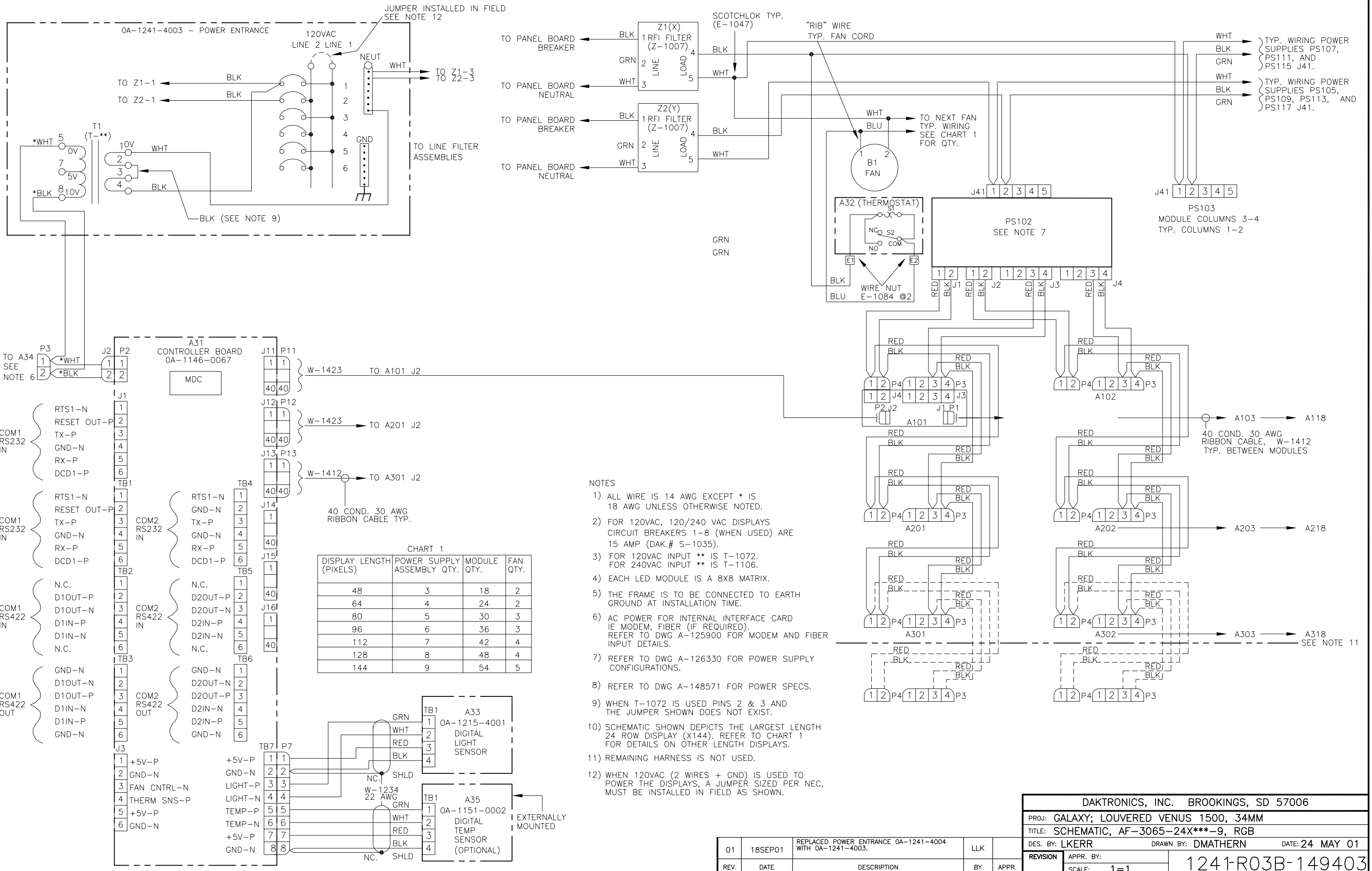

CHART 1

DISPLAY LENGTH (PIXELS)	POWER SUPPLY ASSEMBLY QTY.	MODULE QTY.	FAN QTY.
48	3	18	2
64	4	24	2
80	5	30	3
96	6	36	3
112	7	42	4
128	8	48	4
144	9	54	5

- NOTES
- 1) ALL WIRE IS 14 AWG EXCEPT \* IS 18 AWG UNLESS OTHERWISE NOTED.
  - 2) FOR 120VAC, 120/240 VAC DISPLAYS CIRCUIT BREAKERS 1-8 (WHEN USED) ARE 15 AMP (DAK.# S-1035).
  - 3) FOR 120VAC INPUT \*\* IS T-1072. FOR 240VAC INPUT \*\* IS T-1106.
  - 4) EACH LED MODULE IS A 8X8 MATRIX.
  - 5) THE FRAME IS TO BE CONNECTED TO EARTH GROUND AT INSTALLATION TIME.
  - 6) AC POWER FOR INTERNAL INTERFACE CARD IE MODEM, FIBER (IF REQUIRED). REFER TO DWG A-125900 FOR MODEM AND FIBER INPUT DETAILS.
  - 7) REFER TO DWG A-126330 FOR POWER SUPPLY CONFIGURATIONS.
  - 8) REFER TO DWG A-148571 FOR POWER SPECS.
  - 9) WHEN T-1072 IS USED PINS 2 & 3 AND THE JUMPER SHOWN DOES NOT EXIST.
  - 10) SCHEMATIC SHOWN DEPICTS THE LARGEST LENGTH 24 ROW DISPLAY (X144). REFER TO CHART 1 FOR DETAILS ON OTHER LENGTH DISPLAYS.
  - 11) REMAINING HARNESS IS NOT USED.
  - 12) WHEN 120VAC (2 WIRES + GND) IS USED TO POWER THE DISPLAYS, A JUMPER SIZED PER NEC, MUST BE INSTALLED IN FIELD AS SHOWN.

DAKTRONICS, INC. BROOKINGS, SD 57006

PROJ: GALAXY; LOUVERED VENUS 1500, 34MM  
 TITLE: SCHEMATIC, AF-3065-24X\*\*\*-9, RGB  
 DES. BY: LKERR DRAWN BY: DMATHERN DATE: 24 MAY 01

01	18SEP01	REPLACED POWER ENTRANCE OA-1241-4004 WITH OA-1241-4003.	LLK	
REV.	DATE	DESCRIPTION	BY	APPR.

REVISION APPR. BY: SCALE: 1=1

1241-R03B-149403

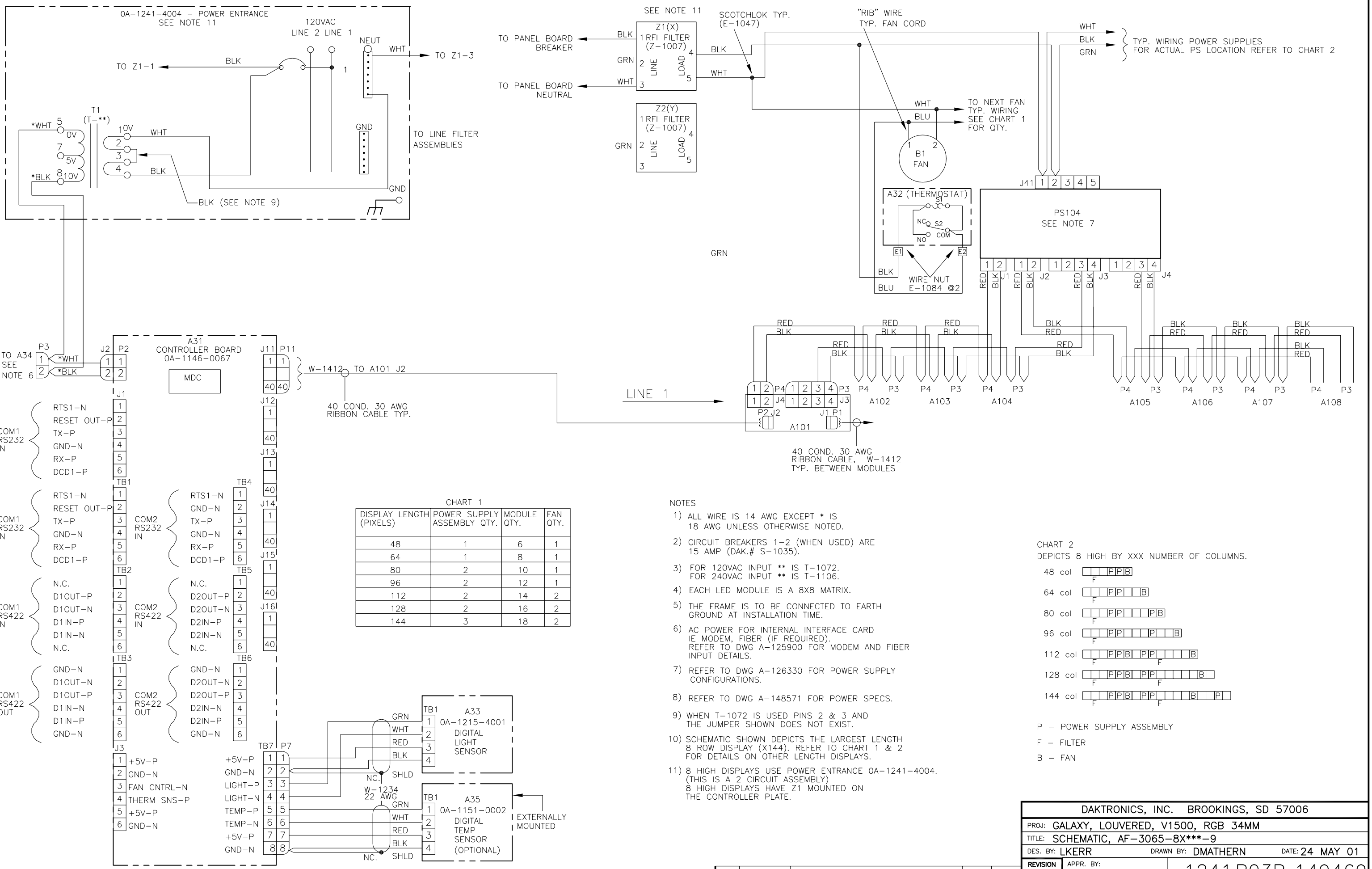

SEE NOTE 11  
 SCOTCHLOK TYP. (E-1047)  
 "RIB" WIRE TYP. FAN CORD  
 WHT  
 BLK  
 GRN  
 TYP. WIRING POWER SUPPLIES FOR ACTUAL PS LOCATION REFER TO CHART 2

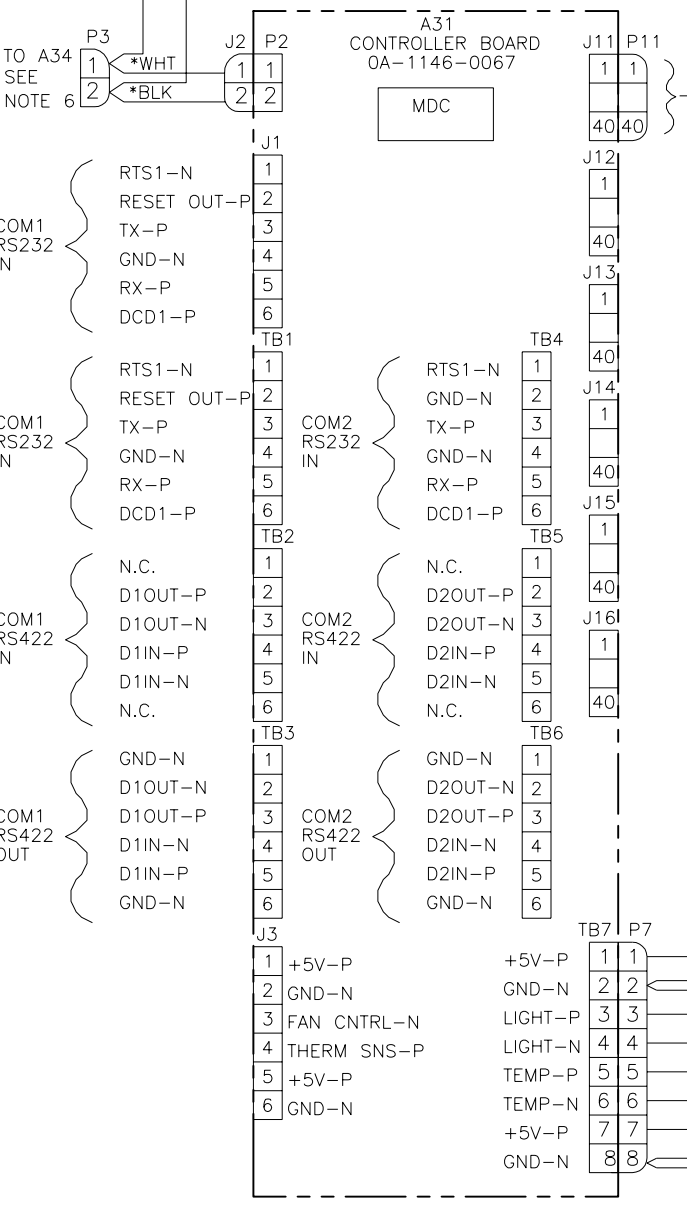
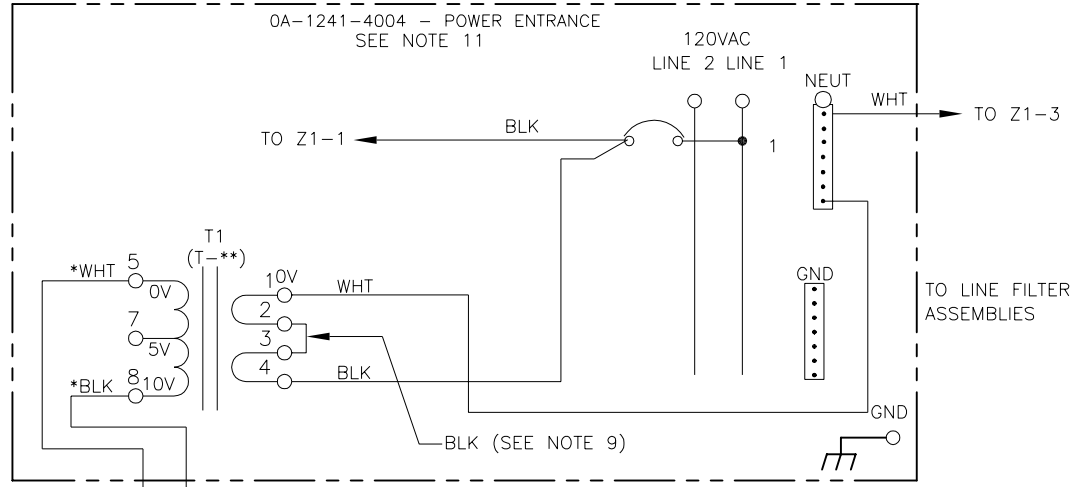
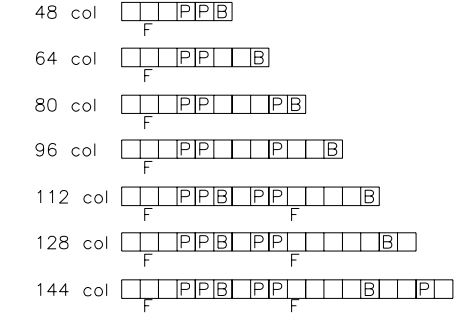

CHART 1

DISPLAY LENGTH (PIXELS)	POWER SUPPLY ASSEMBLY QTY.	MODULE QTY.	FAN QTY.
48	1	6	1
64	1	8	1
80	2	10	1
96	2	12	1
112	2	14	2
128	2	16	2
144	3	18	2

- NOTES
- ALL WIRE IS 14 AWG EXCEPT \* IS 18 AWG UNLESS OTHERWISE NOTED.
  - CIRCUIT BREAKERS 1-2 (WHEN USED) ARE 15 AMP (DAK.# S-1035).
  - FOR 120VAC INPUT \*\* IS T-1072. FOR 240VAC INPUT \*\* IS T-1106.
  - EACH LED MODULE IS A 8X8 MATRIX.
  - THE FRAME IS TO BE CONNECTED TO EARTH GROUND AT INSTALLATION TIME.
  - AC POWER FOR INTERNAL INTERFACE CARD IE MODEM, FIBER (IF REQUIRED). REFER TO DWG A-125900 FOR MODEM AND FIBER INPUT DETAILS.
  - REFER TO DWG A-126330 FOR POWER SUPPLY CONFIGURATIONS.
  - REFER TO DWG A-148571 FOR POWER SPECS.
  - WHEN T-1072 IS USED PINS 2 & 3 AND THE JUMPER SHOWN DOES NOT EXIST.
  - SCHEMATIC SHOWN DEPICTS THE LARGEST LENGTH 8 ROW DISPLAY (X144). REFER TO CHART 1 & 2 FOR DETAILS ON OTHER LENGTH DISPLAYS.
  - 8 HIGH DISPLAYS USE POWER ENTRANCE 0A-1241-4004. (THIS IS A 2 CIRCUIT ASSEMBLY) 8 HIGH DISPLAYS HAVE Z1 MOUNTED ON THE CONTROLLER PLATE.

CHART 2  
 DEPICTS 8 HIGH BY XXX NUMBER OF COLUMNS.



P - POWER SUPPLY ASSEMBLY  
 F - FILTER  
 B - FAN

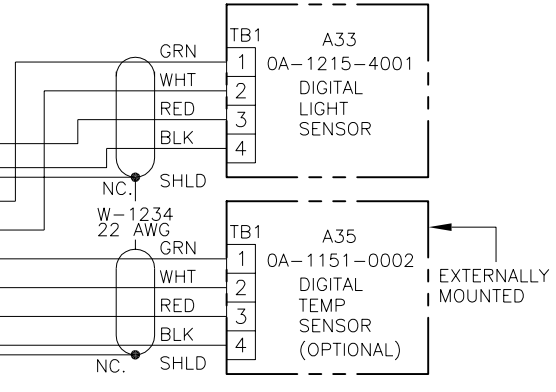

DAKTRONICS, INC. BROOKINGS, SD 57006

PROJ: GALAXY, LOUVERED, V1500, RGB 34MM

TITLE: SCHEMATIC, AF-3065-8X\*\*\*-9

DES. BY: LKERR DRAWN BY: DMATHERN DATE: 24 MAY 01

REVISION APPR. BY: SCALE: NONE

1241-R03B-149469

REV.	DATE	DESCRIPTION	BY	APPR.



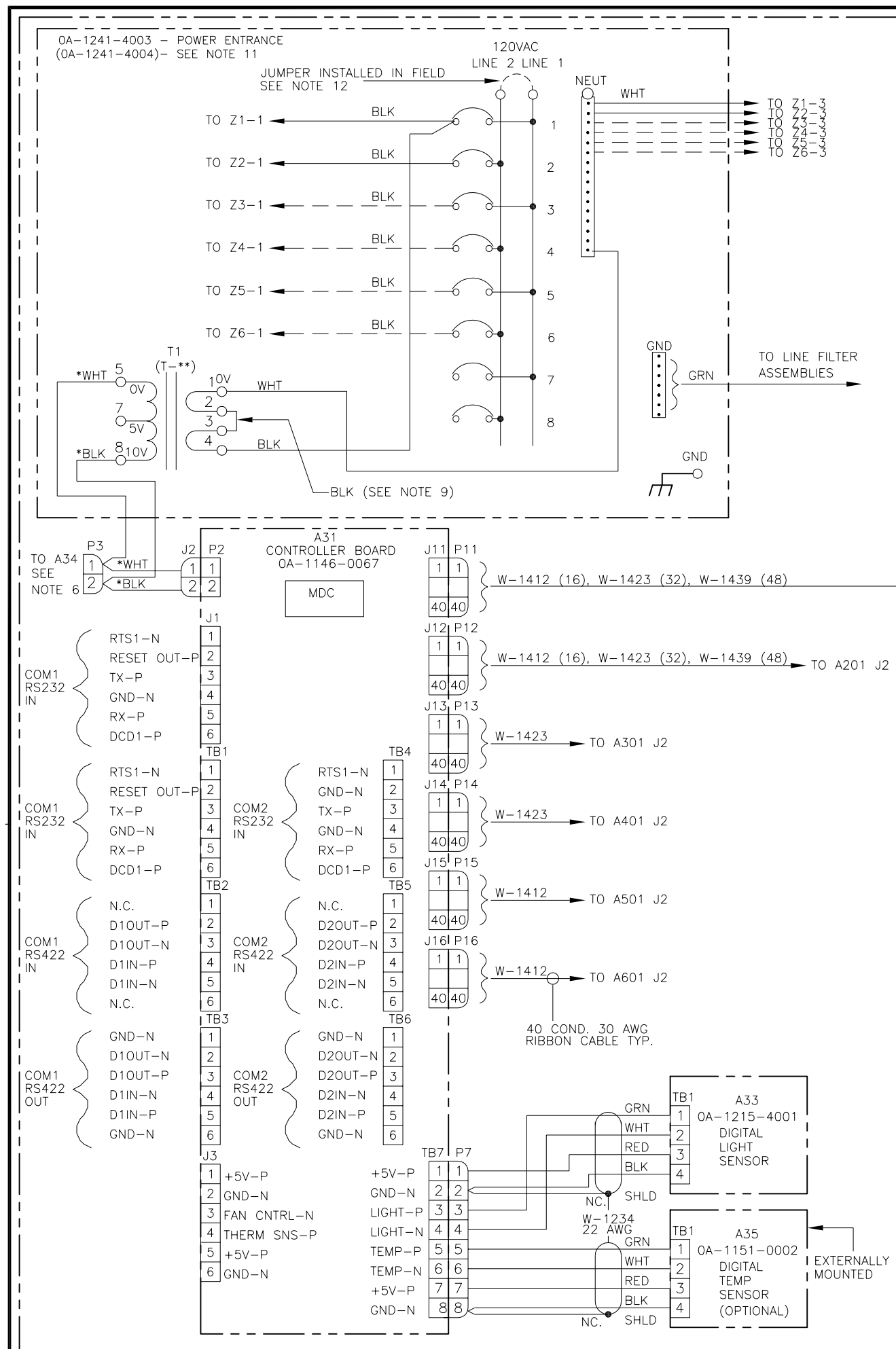

ENCLOSED IS UTILIZED IN ALL DISPLAY SIZES.

NOTES

- 1) ALL WIRE IS 14 AWG EXCEPT \* IS 18 AWG UNLESS OTHERWISE NOTED.
- 2) CIRCUIT BREAKERS 1-8 (WHEN USED) ARE 15 AMP (DAK # S-1035).
- 3) FOR 120VAC INPUT \*\* IS T-1072. FOR 240VAC INPUT \*\* IS T-1106.
- 4) EACH LED MODULE IS A 8X8 MATRIX.
- 5) THE FRAME IS TO BE CONNECTED TO EARTH GROUND AT INSTALLATION TIME.
- 6) AC POWER FOR INTERNAL INTERFACE CARD IE MODEM, FIBER (IF REQUIRED). REFER TO DWG A-125900 FOR MODEM AND FIBER INPUT DETAILS.
- 7) REFER TO DWG A-126330 FOR POWER SUPPLY CONFIGURATIONS.
- 8) REFER TO DWG A-148571 FOR POWER SPECS.
- 9) WHEN T-1072 IS USED PINS 2 & 3 AND THE JUMPER SHOWN DOES NOT EXIST.
- 10) SCHEMATIC SHOWN DEPICTS THE LARGEST LENGTH 16/32/48 ROW DISPLAY (X144). REFER TO CHART 1 FOR DETAILS ON OTHER LENGTH DISPLAYS.
- 11) 16 HIGH DISPLAYS USE POWER ENTRANCE OA-1241-4004. (THIS IS A 2 CIRCUIT ASSEMBLY). 16 HIGH DISPLAYS HAVE Z1 & Z2 FILTERS MOUNTED ON THE CONTROLLER PLATE.
- 12) WHEN 120 VAC (2 WIRES + GND) IS USED TO POWER DISPLAYS, A JUMPER PER NEC MUST BE INSTALLED IN FIELD AS SHOWN.

CHART 1

DISPLAY HEIGHT (PIXELS)	DISPLAY LENGTH (PIXELS)	POWER SUPPLY ASSEMBLY QTY.	MODULE QTY.	FAN QTY.
16	48	2	12	1
16	64	2	16	1
16	80	3	20	2
16	96	3	24	2
16	112	4	28	2
16	128	4	32	2
16	144	5	36	3
32	48	4	24	2
32	64	4	32	2
32	80	6	40	3
32	96	6	48	3
32	112	8	56	4
32	128	8	64	4
32	144	10	72	5
48	48	6	36	3
48	64	6	48	4
48	80	9	60	5
48	96	9	72	6
48	112	12	84	7
48	128	12	96	8
48	144	15	108	9

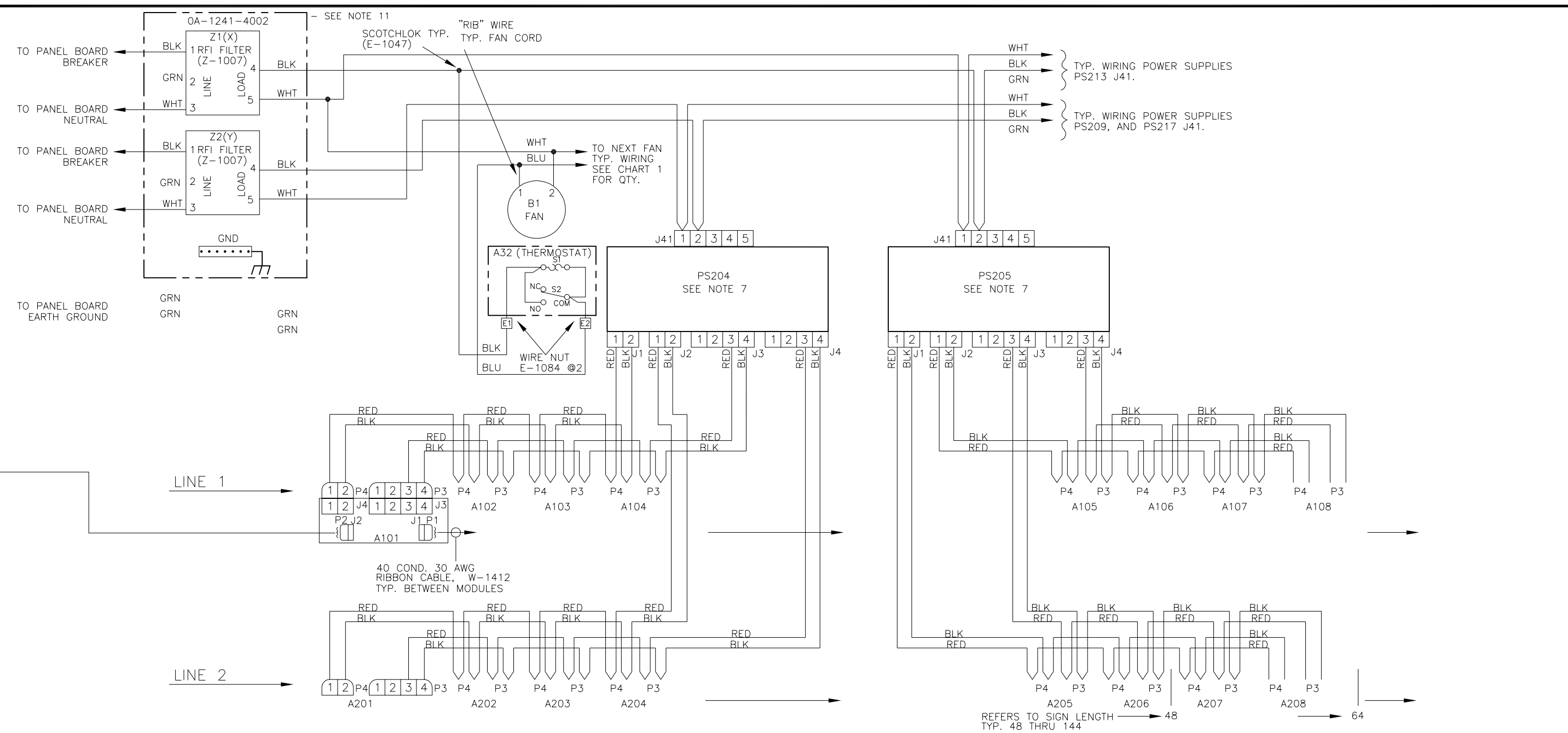

COMPONENTS ABOVE THIS LINE ARE FOR 16 HIGH DISPLAYS

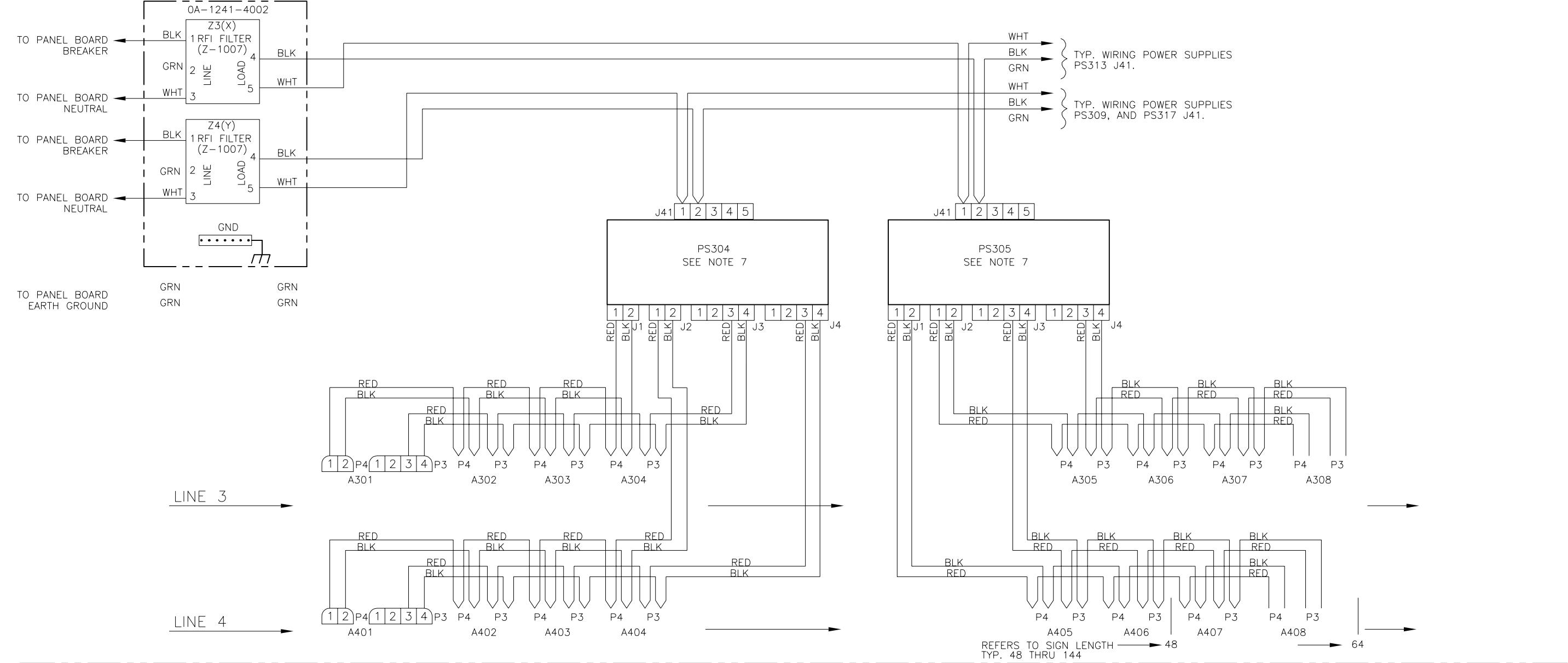

COMPONENTS ABOVE THIS LINE ARE FOR 32 HIGH DISPLAYS

REPEAT ABOVE 2 FILTER CIRCUIT FOR LINES 5 AND 6 ON A 48 HIGH DISPLAY

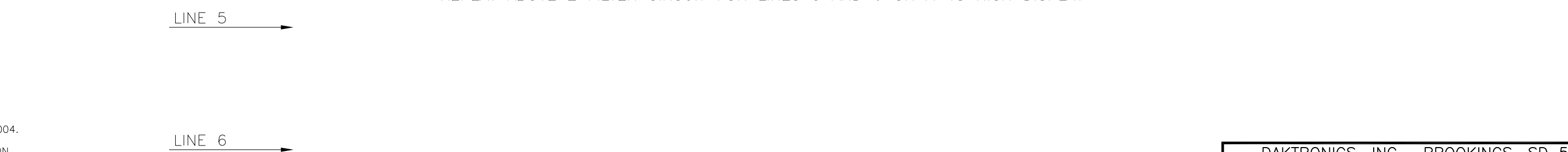

DAKTRONICS, INC. BROOKINGS, SD 57006

PROJ: GALAXY, LOUVERED, V1500, RGB 34MM  
 TITLE: SCHEMATIC, AF-3065-16/32/48\*\*\*-9

DES. BY: LKERR DRAWN BY: LKERR DATE: 17MAY01  
 SCALE: NONE

REV.	DATE	DESCRIPTION	BY	APPR.
01	27 JUL 01	ADDED NOTE FOR 120/240 JUMPER	CCO	

1241-R03C-149070

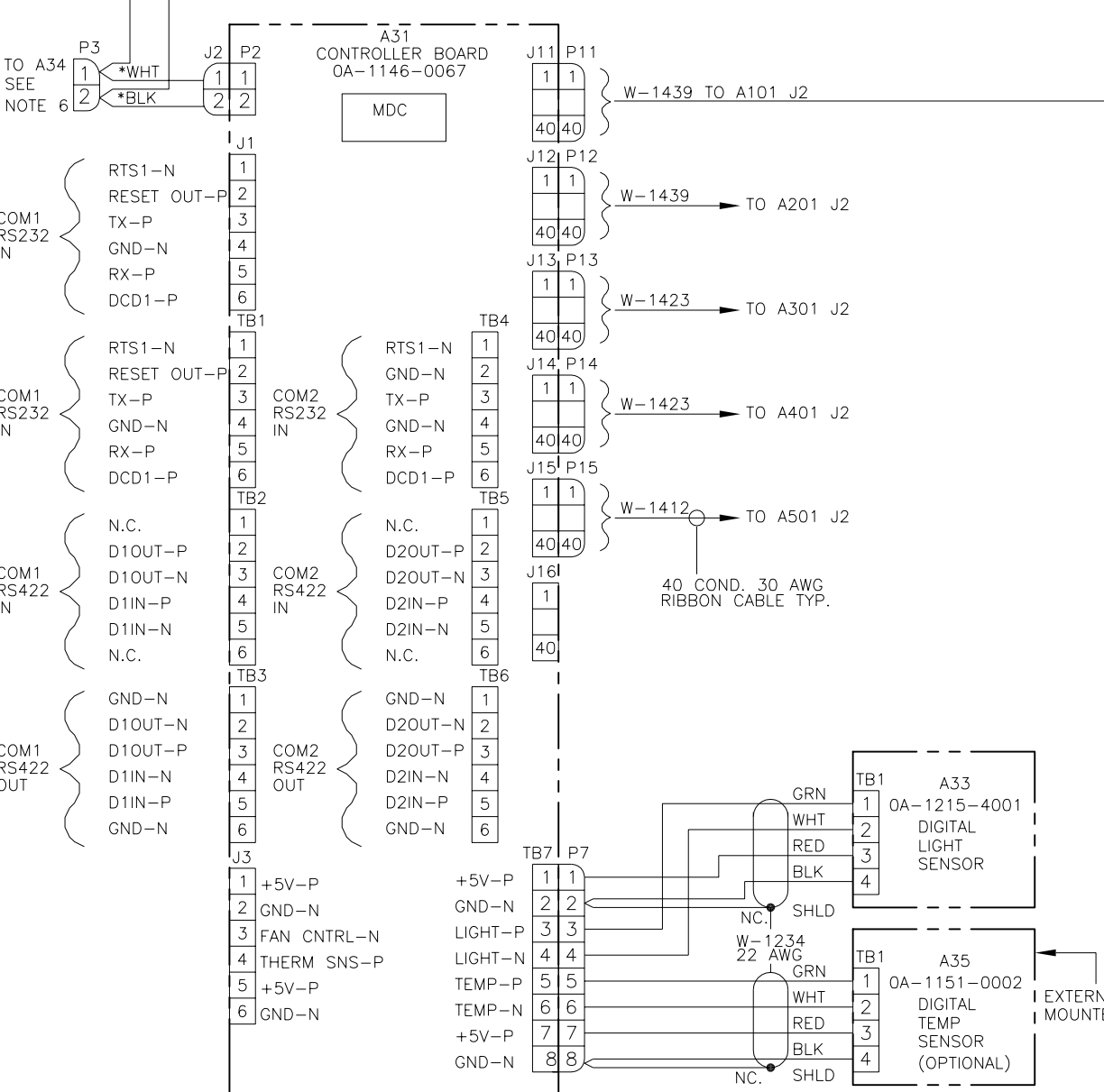
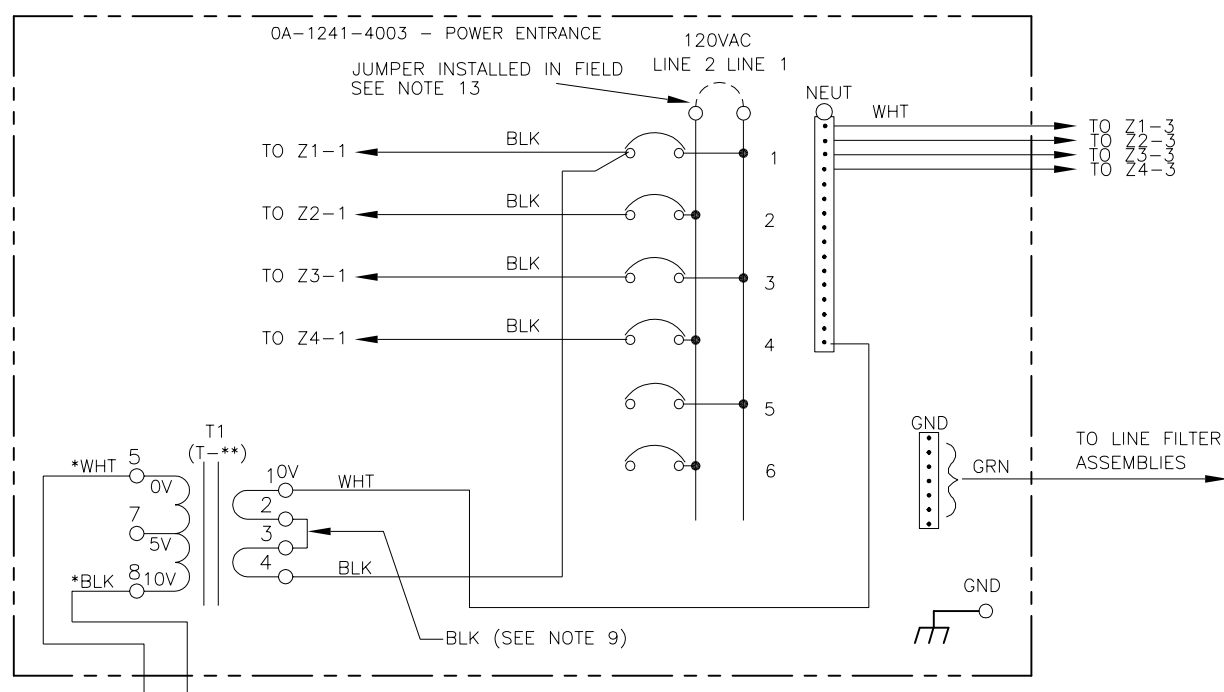
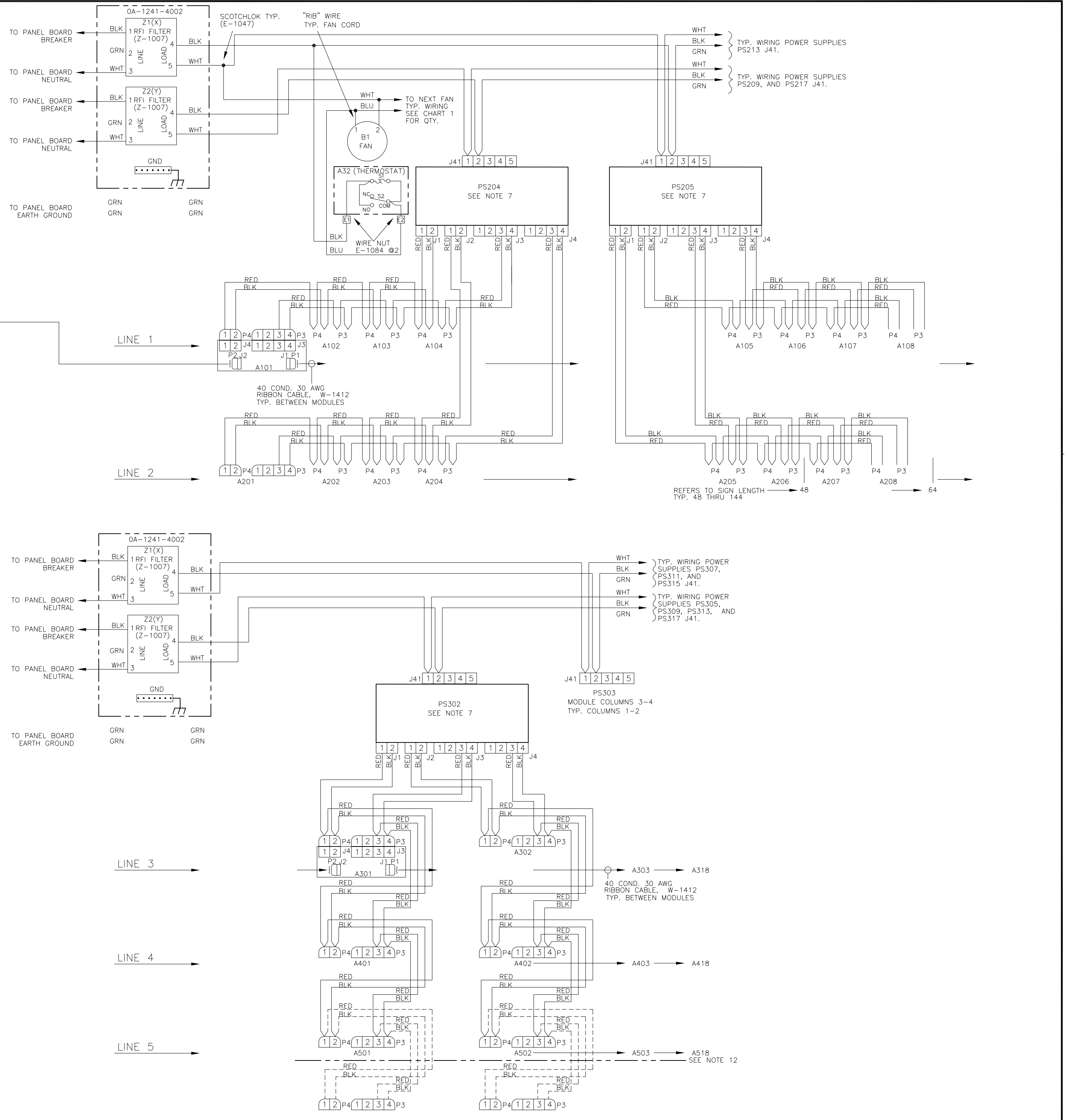

CHART 1

DISPLAY LENGTH (PIXELS)	POWER SUPPLY ASSEMBLY QTY.	MODULE QTY.	FAN QTY.
48	4	30	3
64	5	40	4
80	7	50	5
96	8	60	6
112	9	70	7
128	10	80	8
144	12	90	9

- NOTES
- ALL WIRE IS 14 AWG EXCEPT \* IS 18 AWG UNLESS OTHERWISE NOTED.
  - CIRCUIT BREAKERS 1-6 (WHEN USED) ARE 15 AMP (DAK.# S-1035).
  - FOR 120VAC INPUT \*\* IS T-1072. FOR 240VAC INPUT \*\* IS T-1106.
  - EACH LED MODULE IS A 8X8 MATRIX.
  - THE FRAME IS TO BE CONNECTED TO EARTH GROUND AT INSTALLATION TIME.
  - AC POWER FOR INTERNAL INTERFACE CARD IE. MODEM, FIBER (IF REQUIRED). REFER TO DWG A-125900 FOR MODEM AND FIBER INPUT DETAILS.
  - REFER TO DWG A-126330 FOR POWER SUPPLY CONFIGURATIONS.
  - REFER TO DWG A-148571 FOR POWER SPECS.
  - WHEN T-1072 IS USED PINS 2 & 3 AND THE JUMPER SHOWN DOES NOT EXIST.
  - SCHEMATIC SHOWN DEPICTS THE LARGEST LENGTH 40 ROW DISPLAY (X144). REFER TO CHART 1 FOR DETAILS ON OTHER LENGTH DISPLAYS.
  - 40 HIGH DISPLAYS USE POWER ENTRANCE 0A-1241-4003.
  - REMAINING HARNESS IS NOT USED.
  - WHEN 120 VAC (2 WIRES + GND) IS USED TO POWER DISPLAYS, A JUMPER PER NEG MUST BE INSTALLED IN FIELD AS SHOWN.



REV.	DATE	DESCRIPTION	BY	APPR.
01	27 JUL 01	ADDED NOTE 13 REGARDING 120/240 VAC JUMPER	CCO	

DAKTRONICS, INC. BROOKINGS, SD 57006  
 PROJ: GALAXY, LOUVERED, V1500, RGB 34MM  
 TITLE: SCHEMATIC, AF-3065-40X\*\*\*-9  
 DES. BY: LKERR DRAWN BY: DMATHERN DATE: 24 MAY 01  
 SCALE: NONE 1241-R03C-149437