

**Front-Ventilated
GalaxyPro® GP4 Series**

Installation and Operation Manual

DD2405872

Rev 05—03 April 2015

DAKTRONICS



DAKTRONICS

Copyright © 2013-2015

All rights reserved. While every precaution has been taken in the preparation of this manual, the publisher assumes no responsibility for errors or omissions. No part of this book covered by the copyrights hereon may be reproduced or copied in any form or by any means—graphic, electronic, or mechanical, including photocopying, taping, or information storage and retrieval systems—without written permission of the publisher.

GalaxyPro® and Venus® are trademarks of Daktronics, Inc. All other trademarks are the property of their respective companies

Table of Contents

Section 1:	Introduction.....	1
1.1	Limitation of Liability	1
1.2	Contact Information.....	1
1.3	Model Number Guide	1
Section 2:	Installation Preparation.....	3
2.1	Pre-Installation Checklist	3
2.2	Structure Requirements.....	3
2.3	Electrical Requirements.....	3
	Main Disconnect.....	3
Section 3:	Display Installation	5
3.1	Display Installation.....	5
Section 4:	Electrical Installation.....	7
4.1	Power Connection.....	7
	For displays With an External Power Termination J Box	7
	For Displays With an External Myers Hub Power Termination Box.....	8
4.2	Earth Ground Installation	9
Section 5:	Signal Cable Installation	11
5.1	Primary-Mirror Signal Connection.....	11
5.2	Standard Communication Options.....	11
Section 6:	System Start-Up Procedure	13
6.1	Boot Sequence	13
6.2	Start-Up Checklist	13
Section 7:	Network and Communication Installation.....	15
7.1	Network and Communication Installation Dos	15
7.2	Requirements For Communication Through A Network	15
7.3	Connecting To A Network And Using A DHCP Name.....	15
	Network Requirements	15
	Installation/Start-up Steps	15
7.4	Connecting To A DHCP Network And Using A Static IP Address	16
	Network Requirements	16
	Configuration Steps	16
7.5	Connecting To A Network And Using A Static IP Address.....	16
	Network Requirements	16
	Configuration Steps	17
7.6	Connecting To A Computer Using A Static IP Address.....	17
	Requirements.....	17

	Configuration Steps	17
Section 8:	Venus® 1500 Software Configuration.....	19
8.1	Software Installation	19
8.2	System Requirements	19
8.3	Software Configuration.....	19
Section 9:	Display Maintenance	21
9.1	Internal Display	
	Access.....	21
9.2	Ventilation System	22
	Filter Inspection, Cleaning, and Replacement.....	22
	Fans	22
9.3	Display Face Cleaning.....	22
	Dry Cleaning Process	22
Section 10:	Display Troubleshooting.....	23
10.1	Power and Signal Routing	23
	Power Routing.....	23
	Signal Routing	23
10.2	Player Diagnostics.....	24
10.3	PLR Diagnostics	24
	PLR Self-Test.....	24
10.4	Module and Power Supply Diagnostics	25
	Module Self-Test	25
Section 11:	Replacement Parts List	27
Section 12:	Replacing Parts	29
12.2	Player Replacement.....	29
12.3	PLR Replacement	29
Section 13:	Daktronics Exchange and Repair & Return Programs	31
	Before Contacting Daktronics	31
13.2	Repair & Return Program	32
	Shipping Address.....	32
13.3	Daktronics Warranty and Limitation of Liability.....	32
Appendix A:	Reference Drawings	33
Appendix B:	Daktronics Warranty and Limitation of Liability (SL-2374).....	35

Section 1: Introduction

This manual provides the necessary information to install and service a front ventilated GalaxyPro® GP4 series display.

Please read and understand all steps in this manual before beginning the installation process.

For a smooth installation, complete the steps in this manual in order. Contact Daktronics Technical Support with any questions before or during the installation process.

1.1 Limitation of Liability

The factory warranty will be nullified if:

- The display is not installed according to the steps in this manual
- Proper electrical service is not provided or the display is not grounded properly
- Unauthorized modifications are made to the display, display cabinet, or the control system

Refer to **Appendix B** at the end of this manual for the full Daktronics Warranty and Limitation of Liability.

1.2 Contact Information

For assistance before, during, or after display installation, please contact Daktronics Technical Support: 800-DAKTRONICS (800-325-8766).

1.3 Model Number Guide

GalaxyPro® GP4 model numbers are defined as follows:

GP4-RxC-M-RGB-F		
GP4	=	Outdoor GalaxyPro® 3rd generation display
R	=	Number of pixel rows high
C	=	Number of pixel columns long
M	=	Pixel pitch in millimeters
RGB	=	LED Color: R (Red), G (Green), B (blue)
F	=	Face setup: SF – Single Face or 2V – Primary/Mirror

Figure 1 shows a label on the display's back where the model number and power requirements are located.

Displays are either single face (SF) or two view (2V). In 2V units, the first display is referred to as the primary and the second is called the mirror. If the second display is mounted more than 8 feet (2.4 m) from the primary display, two primary displays are used.

A typical display system consists of a Windows®-based computer running Venus® 1500 software and one or more displays. The Venus® 1500 software package runs on an IBM®-compatible computer. Refer to the [Venus® 1500 software help file](#) for operation instructions.

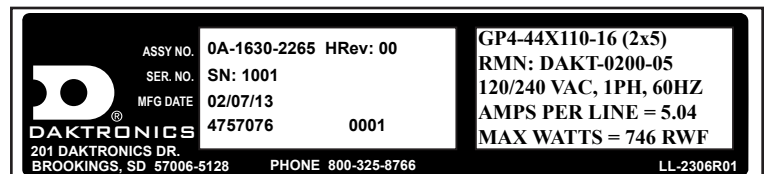

Figure 1: Display Label

Section 2: Installation Preparation

This section explains what to consider before installing a Daktronics GalaxyPro® GP4 display.

Follow all guidelines and safety precautions in this manual when installing the display. Do not modify the display or control system in any manner without the written permission of Daktronics' engineering staff.

Any unauthorized modifications will nullify the display warranty.

2.1 Pre-Installation Checklist

- The display was not damaged during shipping
- The mounting structure will provide a straight and square mounting frame for the display
- The support structure can carry the weight of the display and meets local and national codes
- Ensure proper power is available at sign structure – refer to shop drawing for display power requirements
- The display cabinet has no holes (accidental or intentional) that will allow water to enter the display
- All display modules are fully latched into the display cabinet

2.2 Structure Requirements

Support structure design depends on mounting method, installation height, display size, and weight. Because every installation site is unique, Daktronics approves no single procedure for mounting displays.

Things to consider prior to installation:

- Display structure and mounting must not obstruct airflow - refer to shop drawing for ventilation space requirements
- All clip angles must be used for mounting to structure
- Light sensor must not be obstructed to maintain proper display dimming

For additional questions about display mounting requirements and specifications, refer to the display shop drawing or contact Daktronics Technical Support at 800-DAKTRONICS (800-325-8766).

2.3 Electrical Requirements

Note: Important Note: Size circuits according to local and national codes so the power distribution system delivers full-load power to the display while maintaining a voltage within 5 percent of the nominal voltage.

Main Disconnect

Daktronics requires installation of a power disconnect switch with the display so all ungrounded conductors can be disconnected near the point of power connection.

Section 3: Display Installation

This section explains the steps necessary for proper lifting and installation of the display to the sign structure.

Follow all guidelines and safety precautions in this manual when installing the display.

Do not modify the display or control system in any manner without the written permission of Daktronics' engineering staff. Any unauthorized modifications will nullify the warranty.

Display Installation Dos

- Inspect the display for damage prior to installation
- Use all clip angles for mounting
- Provide an adequate support structure that is straight and level
- Provide adequate ventilation that meets or exceeds display specifications.
Use all lift eyes when lifting the display

Display Installation Don'ts

- Open the DMP-8065 enclosure
- Drill holes into the display
- Block display ventilation system
- Use the lift eyes for display mounting

3.1 Display Installation

1. Carefully remove shipping crate.
2. Attach a crane or lift truck to the lift eyes on the display's top.
Note: Use a spreader beam to ensure proper vertical lift that will not damage the cabinet, as shown in **Figure 2**.
3. Lift the display off the truck to the display structure.
Note: Do not lift displays in wind speeds greater than 20 mph.
4. Mount the display to the structure by welding or bolting all clip angles to horizontal stringers.
Note: Use all clip angles when mounting the display.
5. Remove crane support and tag lines from the display once mounting is complete.

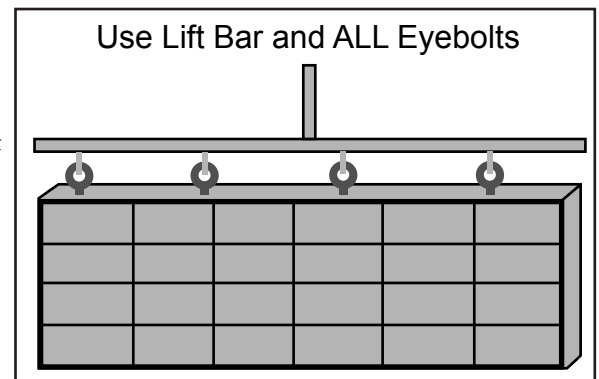

Figure 2: Proper Display Lifting

Section 4: Electrical Installation

This section explains the steps necessary to make final electrical connections to the display from the primary power source. For display-specific power requirements, refer to the shop drawing or label on the display's back.

Electrical Installation Dos

- Follow all installation guidelines
- Route power to the display through a disconnect switch
- Provide the required power per display requirements
- Provide a separate circuit for each display
Note: Daktronics recommends that a separate circuit be run to the electronic display(s) to isolate it and prevent any issues that could be caused by line voltage fluctuations or high frequency noise on the power line caused by other types of equipment. A separate circuit also makes display maintenance and troubleshooting easier. Daktronics assumes no liability for any issues caused by line voltage fluctuations or other improper power conditions if these recommendations are not followed.
- Connect each display face to a dedicated earth-ground electrode
- Follow all local and national electrical codes

Electrical Installation Don'ts

- Share circuits between displays and other electrical devices
- Connect the display to any voltage other than that listed on the product label
- Connect the neutral to the ground at the disconnect or the display
- Use the display support structure as an earth-ground electrode

4.1 Power Connection

Power is terminated externally to the J box on displays.

For displays With an External Power Termination J Box

Terminating hot, neutral, and ground wires at the J box:

1. Route the power cable through conduit to the rear of the display and into the power termination J box, shown in **Figure 3**, (the J box contains $\frac{3}{4}$ " threaded conduit fittings).
2. The J box contains two or three wires plus a ground coming from the



Figure 3: Power J Box

interior of the display. These wires are pre-terminated to the power termination panel inside the display.

3. Inside the external J box, connect the power wires to the wires coming from the display interior using wire nuts. Refer to **Figure 4** for 120/240 VAC.

Note: The following colors are used for the pre-terminated wires:

120/240 VAC

- Line 1 – Black
- Line 2 – Red
- Neutral – White
- Ground – Green/Yellow

For Displays With an External Myers Hub Power Termination Box

1. Review the power requirements for the display. Requirements are found on the display shop drawing or label on the display's back, as shown in **Figure 1**.
2. Route conduit from the main distribution panel/disconnect to each display power entrance. Each display section has a power entrance and requires a dedicated circuit.
3. Remove the four screws that attach the power entrance access door.
4. Connect conduit to the 2" Myers hub at the left of the power entrance box, shown in **Figure 5**.
5. Feed power cable from the conduit into the power entrance box.
6. Connect the power ground wire to the appropriate tap (green wire), as shown in **Figure 6**.
Note: Use a $\frac{3}{16}$ " hex head wrench to tighten screws that hold wires in place.
7. Connect power line 1 (L1) to the appropriate tap (black tape on cable).
8. Connect power line 2 (L2) to the appropriate tap (red tape on cable).
9. Connect the neutral to the appropriate tap (white tape on

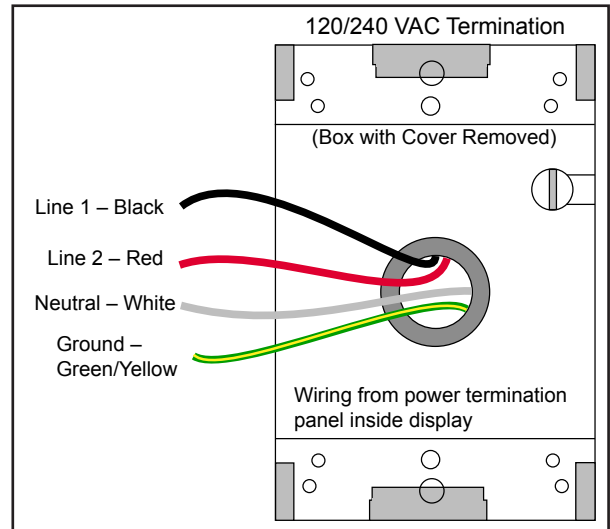

Figure 4: 120/240 V J Box Termination

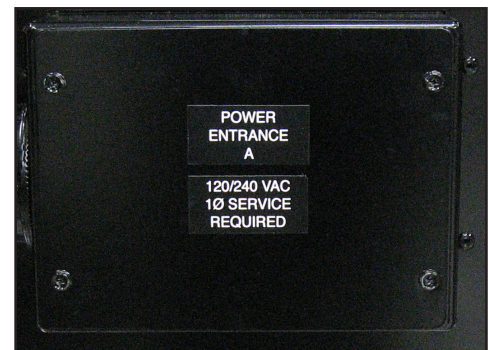

Figure 5: Myers Hub Power Termination Box

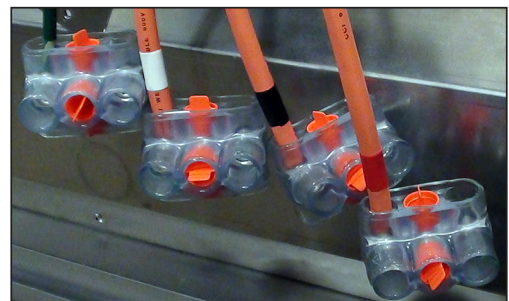

Figure 6: Power Cables

cable).

10. Reinstall the power enclosure cover using all four screws.

4.2 Earth Ground Installation

Daktronics GalaxyPro® GP4 displays require a resistance to ground of 10 ohms or less. Follow the steps below to connect the display to an earth-ground electrode and measure the resistance to ground.

1. Install an earth-ground electrode (ground rod, ground plate, etc.) near the base of the display. Refer to **Figure 7** for guidelines.

Note: Each display face requires an earth-ground electrode.

2. Connect a copper wire from the grounding electrode to the ground lug on the back of the display.
3. Using an Earth Ground Clamp Meter, shown in **Figure 8**, measure the resistance to ground near the grounding electrode. If the reading is greater than 10 ohms, install additional grounding electrodes.

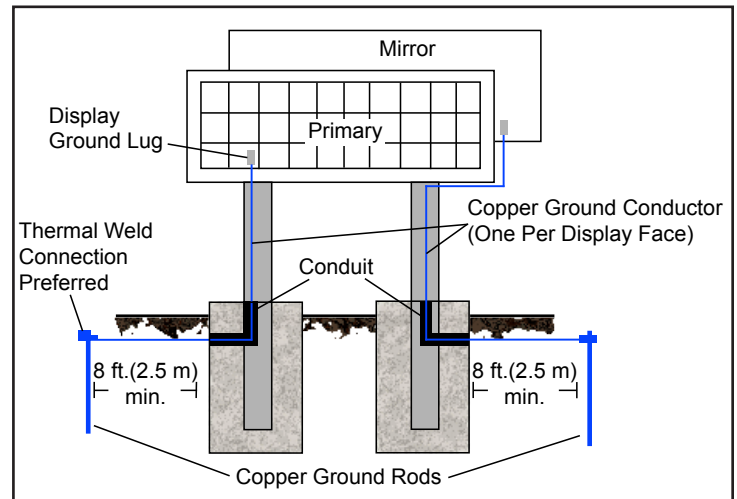

Figure 7: Proper Display Grounding

4. Bury any copper cable or grounding electrodes so they are below grade.

Important points about grounding:

- **Follow local and national codes:** The material of an earth-ground electrode differs from region to region and from conditions present at site. Consult any electrical codes that apply.
- **Support structure cannot be used as an earth-ground electrode:** Daktronics does not recommend using the support structure as an earth-ground electrode; concrete, primer, corrosion, and other factors make the support structure a poor ground.
- **Note:** The support structure may be used as an earth-ground electrode only if designed to do so. A qualified inspector must approve the support structure and grounding methods.
- One grounding electrode for each display face



Figure 8: Measure Resistance to Ground

Section 5: Signal Cable Installation

This section describes signal cable installation for GalaxyPro® GP4 series small matrix displays.

5.1 Primary-Mirror Signal Connection

For data to get from the Primary display to the Mirror display, the fiber interconnect cable must be connected. This cable typically comes attached to the back of the display.

1. Locate cable and unpackage.
2. Connect one end of the cable to J34 on the back of the Primary display, as shown in **Figure 9**.
3. Connect the other end of the cable to J32 on the back of the Mirror display.
4. Coil up any excess cable and secure it to prevent vandalism and weather-related damage.

Note: Anchor points are found on each fan hood for securing excess cable.



Figure 9: Signal Out Quick-Connect Jack

5.2 Standard Communication Options

Daktronics GalaxyPro® GP4 displays can receive various forms of Ethernet communication. The standard communication options are listed below along with the communication-specific document numbers. For additional information regarding communication installation, refer to these documents, which are provided with the communication kits.

Communication Type	Manual Document Number	Quick Guide Document Number
Ethernet – Wire	DD1417609	DD1417573
Ethernet – Fiber	DD1417611	DD1417581
Ethernet Bridge Radio	DD1685027	DD1417586

These are the standard communication types, but each site is unique and may include additional equipment. For questions, contact Daktronics Technical Support.

Section 6: System Start-Up Procedure

Displays show a boot sequence about two minutes after power is turned. This information is very useful when configuring the display in Venus® 1500 software. Prior to turning the display on, make sure display communications and any network connections have been made.

6.1 Boot Sequence

Description
Firmware Name and Version
Display Size (Pixels High by Pixels Wide)
DHCP Name Assigned
IP Address and State
MAC Address
Configuration Port
Status Port
Management Port (Used to Access Configuration)
Description

6.2 Start-Up Checklist

- Confirm power is correctly connected to the display
- Confirm there is sufficient power according to display requirements
- Confirm a main disconnect is installed
- Confirm the display is connected to an earth-ground electrode with a resistance of 10 ohms or less
- Confirm that all communication equipment is installed according to provided documentation
- Confirm that any necessary network connections have been made
- Confirm the control computer has Venus® 1500 software installed
- Inspect peripheral equipment (temperature sensor, light sensor, etc.) for proper installation

Section 7: Network and Communication Installation

This section explains how to setup communications with a GalaxyPro® GP4 series display through a network or an individual computer. Obtain information about the available standard communication options in the provided quick guides and reference manuals.

Daktronics is not responsible for setting up displays on a Wide Area Network (WAN), but can assist with setting up communication on a Local Area Network (LAN) or directly to a personal computer.

7.1 Network and Communication Installation Dos

- Complete all network and communication installation prior to turning display on
- Have a laptop on site with Internet access (preferred)
- Work with the Customer's IT professional for network integration

Daktronics GalaxyPro® GP4 series displays use DHCP by default, which allows automatic display configuration by the customer's network, and eliminates manual configuration of the player.

When the display is connected to a network that supports DHCP, a default DHCP name similar to "DAKTxxxxx", where "xxxxx" represents the last 6 digits of the player's MAC address, is used. This information is shown in the display boot sequence.

7.2 Requirements For Communication Through A Network

- Ports 4500-4525 must be open for communication on the switch or router

7.3 Connecting To A Network And Using A DHCP Name

The following steps explain how to configure a display and connect to a network that supports DHCP and using the display's DHCP name is desired for communication.

Network Requirements

- DHCP Server
- Existing Network
- Available network port, configured properly
- PC with Venus 1500 software installed

Installation/Start-up Steps

1. Make sure computer with Venus 1500 software installed is turned on.
2. Ensure computer has an established link with the network.
3. Turn display on.

7.4 Connecting To A DHCP Network And Using A Static IP Address

The following steps explain how to configure a display when it is connected to a network that supports DHCP, but a static IP address is desired for the display.

Network Requirements

- Existing Network
- Available network port, configured properly
- PC with Venus 1500 software installed
- Static IP information (provided by customer)

Configuration Steps

1. Connect a computer to the display setup for **Obtain IP address automatically**.
2. Turn display on.
3. Launch DisplayFind and discover the display.
4. Once the display is found, click the **link** to launch the configuration utility.
5. Click **Logon** to connect to the display (refer to the help file for additional information about the configuration utility).
6. Configure the IP settings.
7. Click **Upload Configuration**.
8. Log out of the configuration utility.
9. Turn display off.
10. Disconnect the computer from the display and connect display to the network.
11. Make sure computer with Venus 1500 software installed is turned on.
12. Ensure computer has an established link with the network.
13. Turn display on.
14. Configure the display in Venus 1500.

7.5 Connecting To A Network And Using A Static IP Address

The following steps explain how to configure a display when it is connected to a network that does not support DHCP.

Network Requirements

- Existing network
- PC with Venus 1500 software installed
- Static IP information (provided by customer)
- Available network port, configured properly

Configuration Steps

1. Write down the IP address on the computer with Venus 1500 software installed.
2. Change the IP address to **Obtain Automatically**.
3. Allow computer to fail over to DHCP – process may take up to 3 minutes.
4. Turn display on.
5. Launch DisplayFind and discover the display.
6. Once the display is found, click the link to launch the configuration utility.
7. Click **Logon** to connect to the display (refer to the help file for additional information about the configuration utility).
8. Configure the IP settings.
9. Click **Upload Configuration**.
10. Logout of the configuration utility.
11. Turn display off.
12. Change the computer's IP address back (written down in step 1).
13. Turn display on.
14. Configure display in Venus 1500 software.

7.6 Connecting To A Computer Using A Static IP Address

When connecting a display to a computer and not a network, it is recommended to use the USB-to-Ethernet adapter. This allows the computer to maintain any Internet or network connections while still being able to control the display.

Requirements

- PC with Venus 1500 software installed
- USB-to-Ethernet adapter

Configuration Steps

1. Install USB-to-Ethernet adapter driver on computer.
2. Establish a link between the adapter and the display.
3. Turn display on.
4. Launch DisplayFind and discover the display.
5. Once the display is found, click the link to launch the configuration utility.
6. Click **Logon** to connect to the display (refer to the help file for additional information about the configuration utility).
7. Configure the displays IP address to:
IP Address: 172.16.192.25

Subnet Mask: 255.255.0.0

8. Click **Upload Configuration**.
9. Log out of the configuration utility.
10. Turn display off.
11. Configure IP address on USB-to-Ethernet adapter to:
IP Address: 172.16.192.20
Subnet Mask: 255.255.0.0
12. Turn display on.
13. Configure display in Venus 1500 software.

Section 8: Venus® 1500 Software Configuration

Other control software is available on a contract basis. Refer to that product's help file for system requirements, installation, and configuration information.

8.1 Software Installation

Venus® 1500 is the standard control software for GalaxyPro® GP4 displays. Install Venus® 1500 software either from a disc or from www.daktronics.com/venus1500. Click the **Downloads** tab and **Venus1500setup.exe**. Venus® 1500 requires registration which must be completed within 30 days of installation. Refer to the [Venus® 1500 Help File](#) for registration instructions.

8.2 System Requirements

Minimum System Requirements	Recommended System Requirements
Windows XP®, Vista®, or 7® with current updates applied (32-or 64-bit versions)	Windows XP®, Vista®, or 7® with current updates applied (32-or 64-bit versions)
800 Mhz or higher Processor	1.6 GHz or higher Processor
512 MB RAM or higher	1.5 GB RAM or higher
1 GB of Free Hard Disk space (additional space required for content storage)	1 GB of Free Hard Disk space (additional space required for content storage)
Monitor and video adapter capable of 1024x768 or higher resolution with DirectX® 9 support	Monitor and video adapter capable of 1280x1024 or higher resolution with DirectX® 9 support
Microsoft Internet Explorer® 7 or higher	Microsoft Internet Explorer® 7 or higher
.NET 3.5 Framework Service Pack 1	.NET 3.5 Framework Service Pack 1
CD-ROM or DVD drive	CD-ROM or DVD drive
Keyboard and Mouse or other compatible pointing device	Keyboard and Mouse or other compatible pointing device

8.3 Software Configuration

Ensure all display communications and network connections are made before configuring a display in Venus® 1500 software. Once everything is installed, turn the display on, allow it to complete the boot sequence, then follow the steps below.

1. Click the Windows® **Start** button. Hover over **All Programs > Daktronics > Venus 1500 V4**. Click **Venus 1500**.
2. Click the **Application** button, highlight **Configure**, click **Displays**, as shown in **Figure 10**.

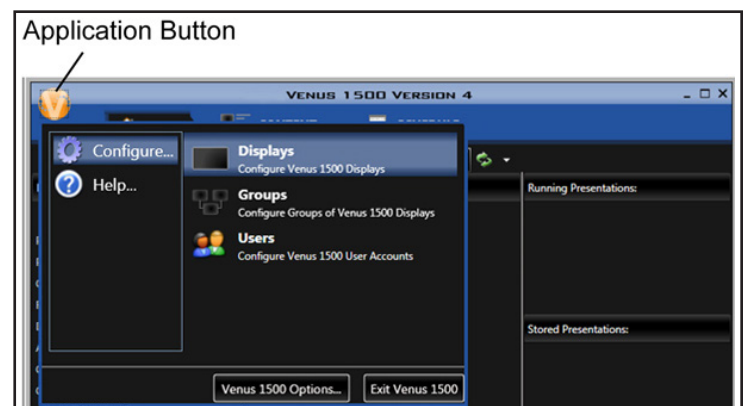

Figure 10: Begin Display Configuration

3. Click **Add Display...** from the **Display Management** window. Or right-click in the **Display Management** window and select **Add Display...**, as shown in **Figure 11**.

4. The software searches for displays on the local network and returns a list of displays it finds.

5. Select the display you wish to configure and click **Continue**, as shown in **Figure 12**.

Note: If the display is password protected, enter the password on the **Authentication Page**. The default password is **DakPassword!**.

Note: Save the password in a secure location. Physical access to the display is required to reset the password if it is lost.

6. Give the display an easy-to-identify name when the **Display Found** prompt opens. This prompt also provides a brief description of the display. Click **Continue**. **Note:** If the display is not found, refer to the [Venus 1500 Help File](#) for manual configuration instructions.

7. Select the correct time zone for the display's location. Greenwich Meantime, along with country and city or region are the guides used to select the correct time zone.

8. A Summary box, shown in **Figure 13**, provides basic information about the newly configured display. Click **Back to Start** to return to the beginning of the process to configure another display. Click **Finish** to complete display configuration.

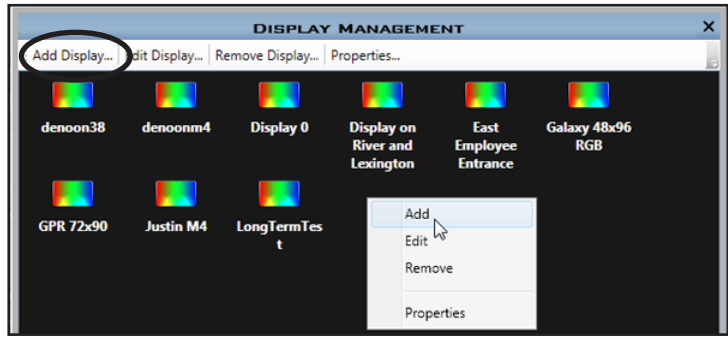

Figure 11: Configure a New Display

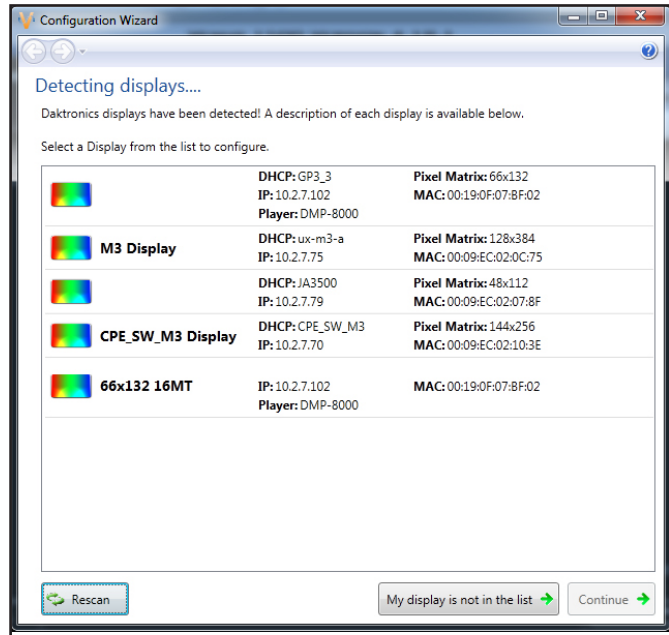

Figure 12: Displays Found List

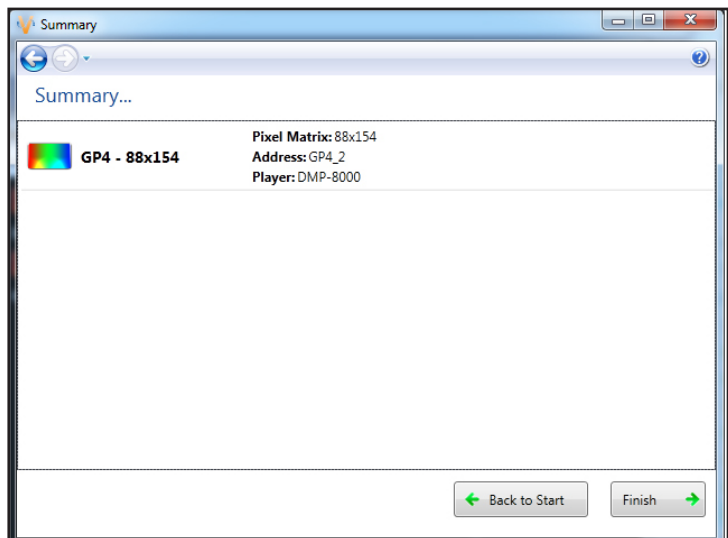

Figure 13: Display Configuration Summary Window

Section 9: Display Maintenance

This section explains the steps necessary to maintain the GalaxyPro® GP4 display. Daktronics GalaxyPro® GP4 displays are front accessible. Remove modules on the front of the display to gain access to internal components. **Figure 14** and **Figure 17** show internal component locations.

Important Notes: Turn OFF power before any repair or maintenance work is done on the display.

9.1 Internal Display Access

1. Disconnect power to the display.
2. Locate the two access holes to gain access to the quarter-turn fasteners on the module.
3. Using a $\frac{1}{8}$ " hex head wrench, turn each latch a quarter turn counter-clockwise.
4. Gently pull the module far enough forward to reach behind and disconnect the power and signal cables.

Note: Do not allow module to hang by its cables. Doing so causes irreversible damage to the module. Use the provided lanyards to hang a module, as shown in **Figure 15** and **Figure 16**.

5. When ready to reinstall the module, reconnect the cables, push the cables into the display so they do not get pinched and latch the module using a $\frac{1}{8}$ " hex head wrench.
Note: A fully seated module should be flush with the modules around it.

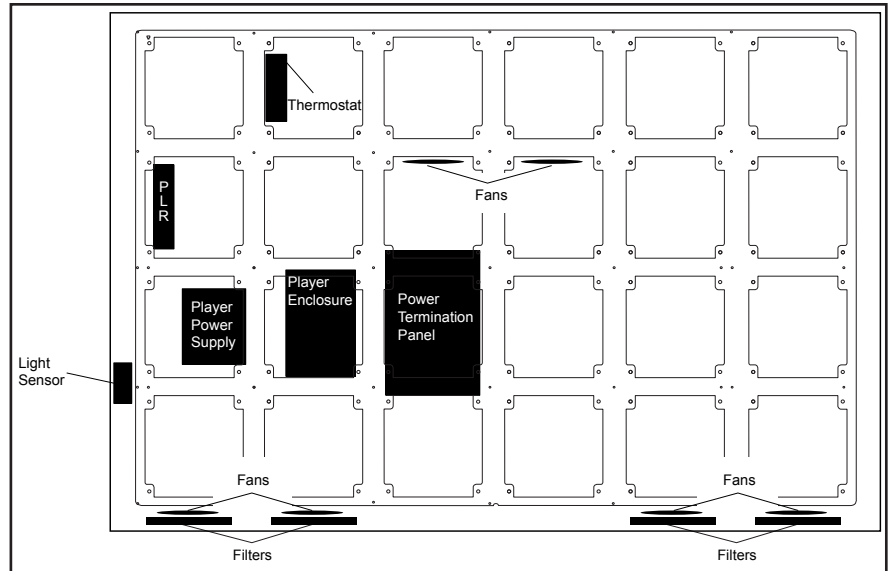

Figure 14: Component Locations In Lower Left of Display

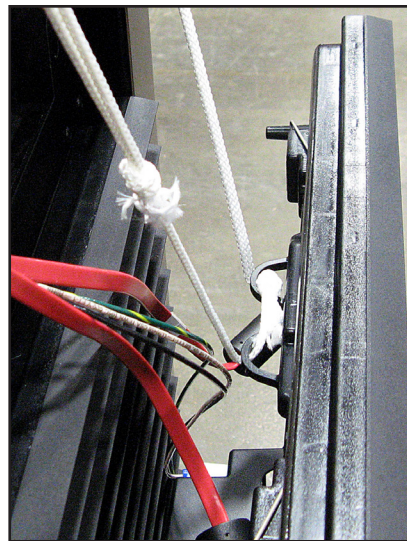

Figure 15: Lanyard Attachment Top View

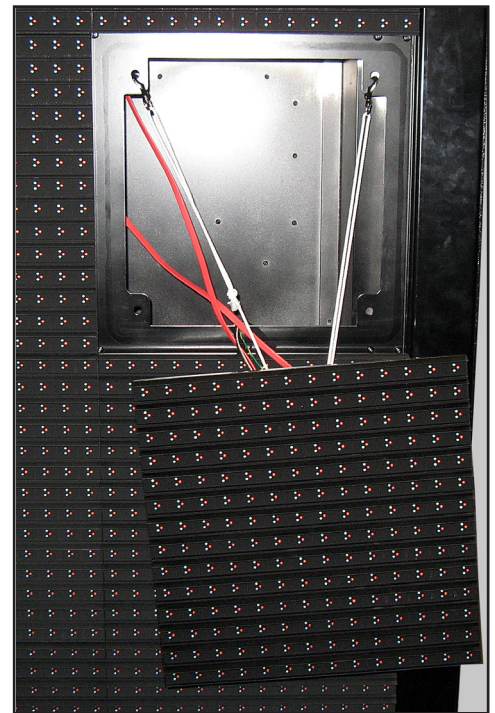

Figure 16: Module Attached To Lanyard

9.2 Ventilation System

GalaxyPro® GP4 displays are equipped with a ventilation system that helps keep internal components at operable temperatures. GalaxyPro® GP4 displays are rear ventilated, so the display support structure must allow adequate space or air movement for proper ventilation. Refer to the display shop drawing for ventilation requirements.

Filter Inspection, Cleaning, and Replacement

The ventilation system includes filters that prevent dirt and debris from entering the display cabinet. Check and replace filters regularly to ensure adequate air flow in the display. At a minimum, check filters every six months, but more frequent inspection may be required depending on conditions around the display.

Clean filters with water or compressed air (no greater than 60 psi and at least 6" away) blown through the filter in the opposite direction from which air normally flows. Allow filters to dry before returning them to their trays. Again, Daktronics encourages users and service technicians to use their own discretion when deciding whether to clean or replace the filters.

Fans

Fans help bring fresh air into the display while exhausting hot air through the upper vents. Fans are controlled via a thermostat in the display cabinet. The thermostat is equipped with a bypass button for testing fan operation. Replace fans that are not working properly.

9.3 Display Face Cleaning

Wet Cleaning Process

1. Turn off power to the display.
2. Mix a mild, non-abrasive, non-petroleum-based detergent and cold water, one ounce of detergent to one gallon of cold water.
3. Saturate a light/medium duty cleaning brush with the soapy water.
4. Use horizontal brush strokes to loosen and remove dirt and grime, washing the display from top to bottom. Use light pressure so as not to damage the LEDs. Clean only an area that is safely within reach from a lift or stage, and then move on to the next section of modules.
5. Rinse the display face with generous amounts of cold water under low pressure. A spot-free rinse agent can be used to reduce water spots.
6. Use soft, dry terry cloth to dry and remove any excess water. Take care not to damage LEDs by catching the cloth on them.
7. Allow the display to completely air-dry for 12 hours before applying power to the display.

Dry Cleaning Process

1. Turn off power to the display.
2. Rub a dry, soft terry cloth towel horizontally across each row of LEDs. Make four passes per row of LEDs before moving to the next row of LEDs. Work from top to bottom safely within reach from a lift or a stage. Take care not to damage LEDs or the plastic louvers by catching the cloth on them.

Section 10: Display Troubleshooting

This section provides basic display information such as power and signal routing as well as basic troubleshooting tips for common problems. For issues not addressed in this manual, please contact Daktronics Technical Support.

10.1 Power and Signal Routing

Understanding power and signal flow through the display can help a technician troubleshoot an issue.

Power Routing

Figure 17 shows how power is routed through the display.

1. AC Power enters the display through the power entrance box on the back of the display and travels to the Power Termination Panel (1).
2. Power is distributed to Module Power Supplies (2a), Player Power Supply (2b), Thermostat (2c), and Fans (2d).
Note: Each module has its own Module Power Supply attached to the back of the module.

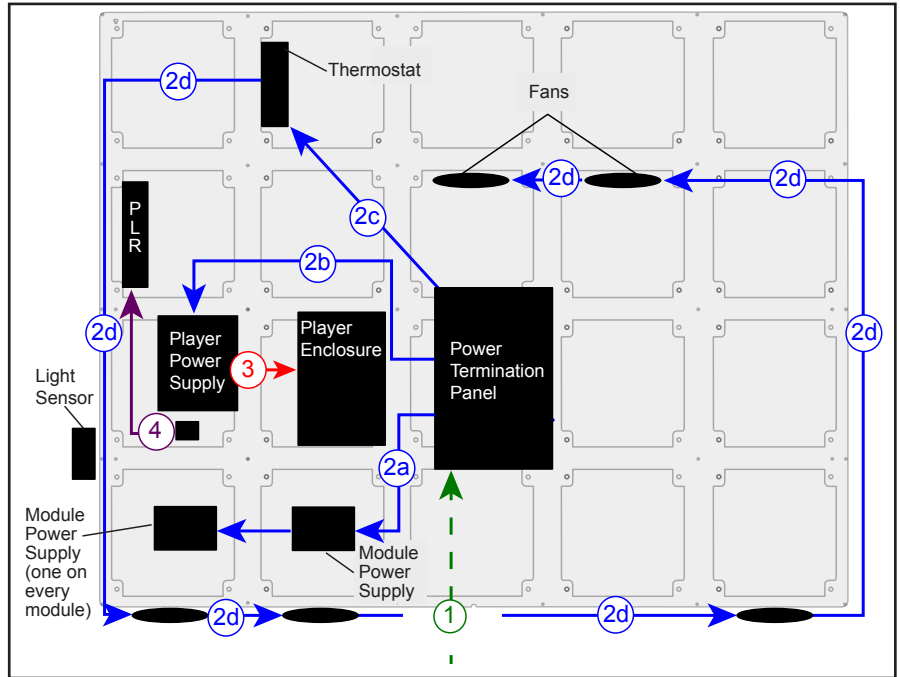

Figure 17: Power Routing

3. DC Power is supplied to the Player (3) from the Player Power Supply.
4. DC Power is also supplied to the PLR (4) from the PLR power jack on the back of the module.

Signal Routing

Figure 18 shows how signal is routed through the display.

1. Signal enters the display from the external signal enclosure through the signal input quick-connect jacks (1).
2. Signal travels from the J32 signal input jack through an Ethernet Cat5e cable to the J32 Ethernet jack on the player (2a).
 - The J33 auxiliary input jack and the temperature sensor,

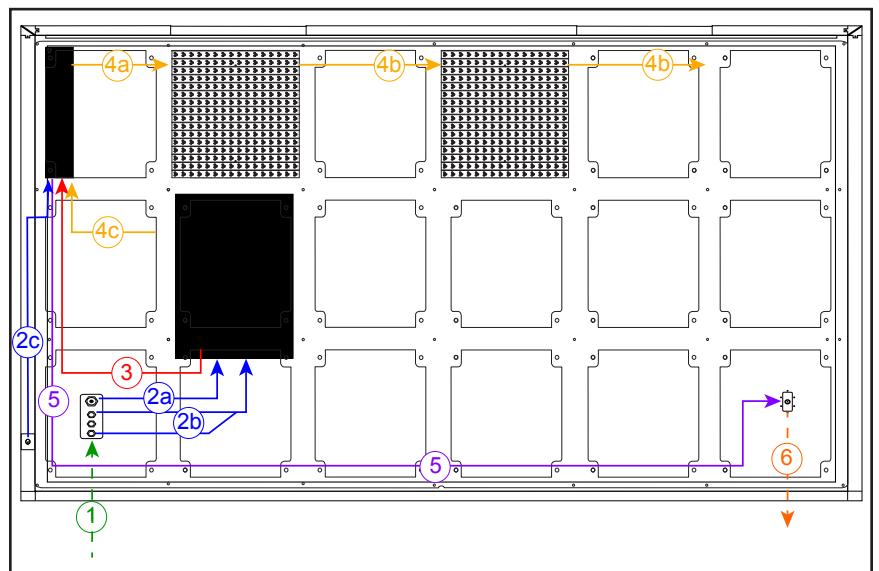

Figure 18: Signal Routing

which is connected to the J31 input quick-connect jack, connect to the J36 jack on the player (2b).

- The light sensor is connected to the J8 jack on the PLR (2c).
3. Signal travels from the player from Fiber A to the PLR Port A (3).
 4. From SATA A on the PLR, signal goes to the first module (4a) and travels from module to module via SATA cables (4b), finally returning to the PLR to SATA B (4c).
 5. Signal leaves the PLR from Fiber B and travels to the Output Fiber Quick Connect (5).
 6. Signal from the primary display face Output Fiber Quick Connect travels to the mirror face (6) to jack J32.

10.2 Player Diagnostics

DMP-8065 is the player in a GalaxyPro® GP4 display. The player is located in the lower-left portion of the display in an environmental enclosure. The player receives incoming signal from the control computer and routes that signal to the ProLink Router (PLR). The player has three LEDs on it that can be useful when troubleshooting a communication issue. **Figure 19** shows those LEDs.

10.3 PLR Diagnostics

The ProLink Router (PLR), receives signal from the display player, which transfers it on to the modules through SATA cables. GalaxyPro® GP4 displays are equipped with a redundant signal path, meaning two SATA cables are connected to each module. If one of the two SATA cables fail, the module continues to receive data from the other SATA cable and the display continues functioning normally.

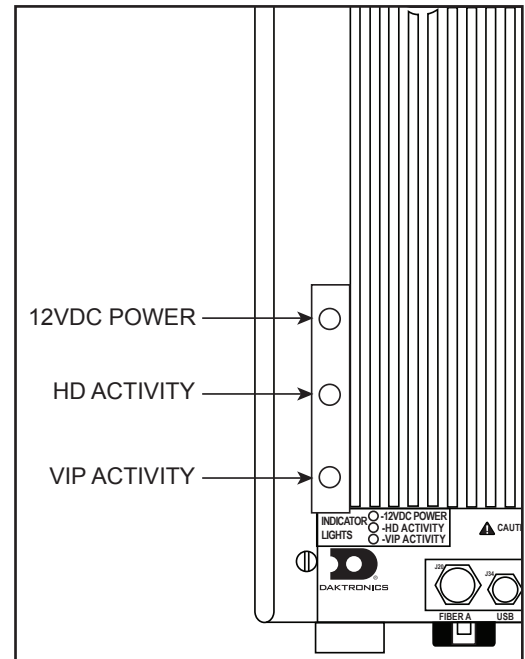

Figure 19: Controller Diagnostic LEDs

PLR Self-Test

When put into self-test mode, the PLR tests for correct operation and displays pass/fail status on the 7-segment display.

To put the PLR into self-test mode, loop a SATA cable between ports A and B. Then take a fiber cable and connect the fiber ports together, as shown in **Figure 20**. Once the cables are connected, cycle power to the PLR and it will boot-up in self-test mode. Following is a table of a few possible messages. Contact Daktronics Technical Support for additional information or questions.

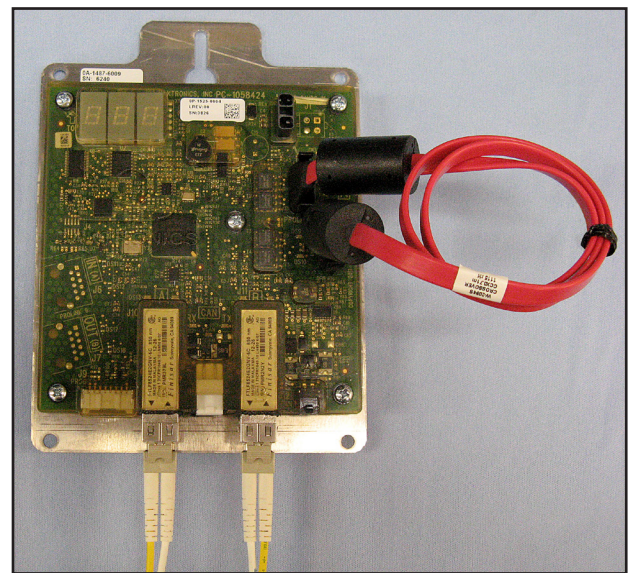

Figure 20: PLR Self-Test Setup

Code			Description
8	8	8	Testing 7 segments (held for 2 seconds)
t	s	t	Initial test in progress (60-second duration)
P	A	S	All tests passed
E	r	r	Test failures reported
F	0	1	Fiber Port A Error
F	0	2	Fiber Port B Error
F	0	3	RJ45 IN (Port A) Error
F	0	4	RJ45 OUT (Port B) Error
F	0	5	ProLink5 (SATA) Port A Error
F	0	6	ProLink5 (SATA) Port B Error
C	N	P	CAN Light Sensor (J8) Port Pass
C	N	F	CAN Light Sensor (J8) Port Fail

If any Err message is displayed, send the PLR back to Daktronics for repair or replacement.

10.4 Module and Power Supply Diagnostics

Each module in a GalaxyPro® GP4 display has a power supply attached to it. Each power supply provides power only to the module it is connected to. Display modules are equipped with a status indicator LED that can help troubleshoot possible issues. Under normal operation, the status indicator LED should flash once every 4 seconds.

Module Self-Test

If a module is blank, but has power supplied to it, perform a module self-test to diagnose a module or SATA cable failure. To perform a self-test, follow the steps below.

1. Attach a SATA cable to Port A and Port B on the module, as shown in **Figure 21**.
2. Disconnect the power to the power supply for 10 seconds.
3. Reconnect the power to start the self-test.
4. Verify the module is running a self-test.

Remove the SATA cable and cycle power to the module to stop the self-test.

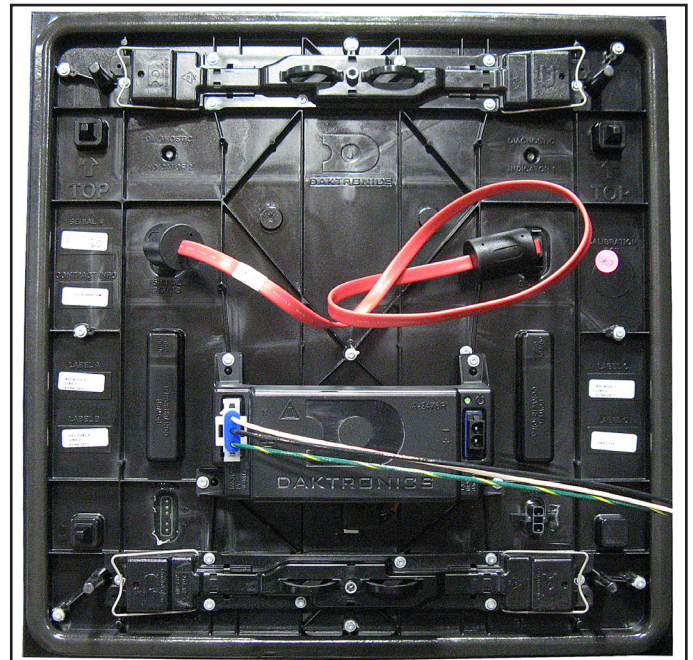

Figure 21: Module Self-Test

Section 11: Replacement Parts List

The following table contains some of the items that may need to be replaced over a period of time. All GalaxyPro® GP4 displays ship with at least two spare modules with power supplies and two spare SATA cables depending on the size of the display.

If a component is not listed in the replacement parts list, use the label to order a replacement. Most components within displays carry a label that lists the part number of the unit. A typical label is shown in **Figure 22**, with the part number in bold.

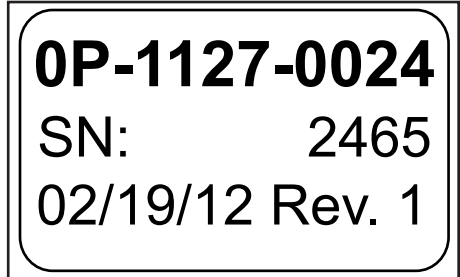

Figure 22: Typical Parts Label

Part Number	Description
0A-1576-7200	26 mm Module With Power Supply Attached
0A-1586-7200	20 mm Module With Power Supply Attached
0A-1621-7200	16 mm Module With Power Supply Attached
0A-1603-3000	DMP-8065 Controller Enclosure Assembly
0A-1487-6009	PLR Assembly
W-2094	SATA Cable, 2 Foot
W-2410	SATA Cable, 28 Inch
W-1659	Fiber Cable, 3 Foot
W-2152	Signal Cable, 36 Inch
W-2284	Ethernet Cable, 3 Foot
B-1045	Fan Assembly
0A-1327-1153	Quick Connect, Primary Input
0A-1327-1095	Quick Connect, Primary Output
0A-1327-1096	Quick Connect, Mirror Input
0A-1327-1152	Quick-Connect Plate, Primary Input
W-1685	Fiber-Optic Cable, 33 Foot
W-1658	Fiber-Optic Cable, 10 Foot
0A-1327-3104	Thermostat Assembly
0A-1327-3018	Light Sensor Assembly
W-2497	Light Sensor Cable, 3 Foot
A-2476	12 Volt Power Supply (For Player, DMP-8065)
EN-2241	Air Filter, 3.625" x 32" x .75"
EN-2242	Air Filter, 3.625" x 19" x .75"
W-2499	Controller to Quick Connect Cable, M12
0A-1151-0010	Temp Sensor Assembly

Section 12: Replacing Parts

12.1 Module and Power Supply Replacement

Each module in a GalaxyPro® GP4 display has an attached power supply and is replaced as an entire assembly.

Note: When removing modules from the display, do not allow them to hang by the cables. Lanyards, shown in **Figure 15**, are provided with the spare parts kit for hanging modules.

1. Turn off power to the display.
2. Remove module using a $\frac{1}{8}$ " hex head wrench.
3. Pull the module slightly out of the display.
4. Disconnect the power cable to the power supply.
5. Carefully disconnect the two SATA cables from the module.
6. Connect the two SATA cables to the new module.
7. Connect power to the power supply.
8. Reinsert the module making sure not to pinch any cables.
9. Latch the new module into place making sure it is fully seated.

12.2 Player Replacement

The player is located in the lower-left area of the display, as shown in **Figure 14**. From the bottom-left corner of the Primary face, go up to the second row of modules and over to the right two modules to locate the player. **The player is in an enclosure which is not to be opened. Replace the entire enclosure.**

1. Remove the modules in front of the player.
Note: Do not allow the modules to hang by their cables
2. Disconnect the cables at the bottom of the enclosure.
3. Disconnect player fan power cable from jack J5.
4. Loosen the four nuts connecting the enclosure to the back of the display.
5. Carefully lift the enclosure up and out of the display.
6. Insert the new enclosure and tighten all four nuts.
7. Reattach the cables to the bottom of the enclosure using the label as a guide.
8. Reconnect player fan power cable to jack J5.

12.3 PLR Replacement

The PLR is located behind the second module up from the bottom in the first column of modules, as shown in **Figure 14**. PLRs can be found in both Primary and Mirror display faces as well as all sections of a sectional display.

1. Remove the module in front of the PLR.
Note: Do not allow module to hang by its cables.
Note: This module will likely have four cables attached as it provides power to the PLR.
2. Disconnect the two SATA cables and fiber cables to the PLR.
3. Loosen the screw at the top of the PLR mounting plate.
4. Lift the mounting plate up and out of the display.
5. Insert the new PLR with mounting plate and tighten the screw.
6. Insert the two SATA cables and fiber cables in the appropriate locations.

Section 13: Daktronics Exchange and Repair & Return Programs

13.1 Exchange Program

The Daktronics Exchange Program is a quick, economical service for replacing key components in need of repair. If a component fails, Daktronics sends a replacement part to the customer who, in turn, returns the failed component to Daktronics. This not only saves money but also decreases equipment downtime. Customers who follow the program guidelines explained below will receive this service.

Before Contacting Daktronics

Fill in these numbers before calling Customer Service:

Display Model Number: _____

Date Installed: _____

Location of Display: _____

Daktronics Customer ID Number: _____

To participate in the Exchange Program, follow these steps:

1. Call Daktronics Customer Service: 866-343-3122.
2. When the new exchange part is received, mail the old part to Daktronics.
If the replacement part fixes the problem, send in the problem part which is being replaced.
 - a. Package the old part in the same shipping materials in which the replacement part arrived.
 - b. Fill out and attach the enclosed UPS shipping document.
 - c. Ship the part to Daktronics.
3. A charge will be made for the replacement part immediately, unless a qualifying service agreement is in place. In most circumstances, the replacement part will be invoiced at the time it is shipped.

If the failed part or replacement part is not returned to Daktronics within 3 weeks of the ship date, Daktronics will assume that the customer is purchasing the replacement part and will send an invoice for the value of the new sale part. If the part or parts are returned within 2 weeks of the second invoice date, Daktronics will credit the customer for the second invoice.

If after 2 weeks Daktronics has still not received the parts back, the customer must pay the second invoice and will not be credited for the return of the failed part. Daktronics reserves the right to refuse parts that have been damaged due to acts of nature or causes other than normal wear and tear.

13.2 Repair & Return Program

For items not subject to exchange, Daktronics offers a Repair & Return Program. To send a part for repair, follow these steps:

1. Call or fax Daktronics Customer Service:
Phone: 866-343-3122 Fax: 605-697-4444
2. Receive a Return Materials Authorization (RMA) number before shipping.
This expedites repair of the part.
3. Package and pad the item carefully to prevent damage during shipment.
Electronic components, such as printed circuit boards, should be placed in an antistatic bag before boxing.
4. Enclose:
 - Your name
 - Address
 - Phone number
 - The RMA number
 - A clear description of symptoms

Shipping Address

Daktronics Customer Service

PO Box 5128

201 Daktronics Dr.

Brookings SD 57006

13.3 Daktronics Warranty and Limitation of Liability

The Daktronics Warranty and Limitation of Liability is located in Appendix B. The Warranty is independent of Extended Service agreements and is the authority in matters of service, repair, and display operation.

Appendix A: Reference Drawings

Shop drawings show display dimensions, signal and power connection locations, as well as information on service access and power requirements. To obtain copies of reference drawings specific to your display, contact Daktronics Customer Service:

Phone: 866-343-3122 Fax: 605-697-4444

Click [here](#) for GP4 shop drawings.

GP4 SATA Cable Routing	B-1116128
GP4 Block Diagram, DMP-8065.....	B-1113798
GP4 Fiber Routing.....	B-1116123
GP4 VAC Harnessing, Fan Circuit Layout.....	B-1116126

Appendix B: Daktronics Warranty and Limitation of Liability (SL-2374)
